

LP-2

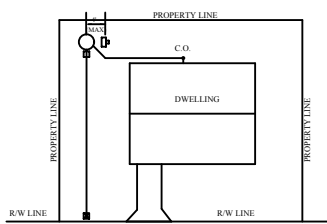

TYP. ALTERNATE LOCATION

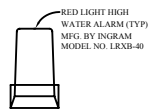

ALARM LIGHT DETAIL

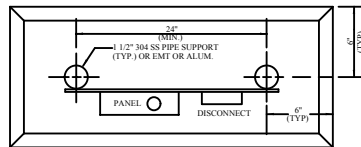

PLAN VIEW
ELECTRICAL PANEL
& CONCRETE PAD

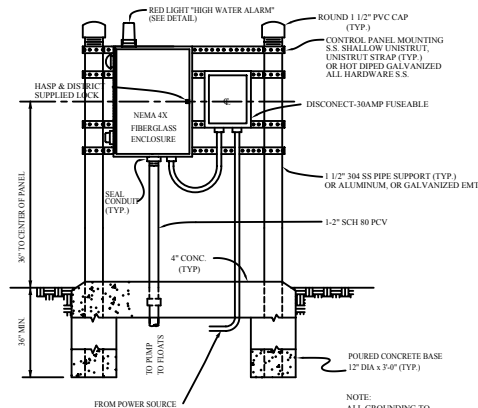

FRONT ELEVATION

SIMPLEX RESIDENTIAL GRINDER - PUMP CONTROL PANEL DETAILS
ALTERNATE LOCATION (FREE STANDING)

(N.T.S.)

LOW PRESSURE FORCE MAIN SYSTEM

REV 9-99, 01-04, 07-06

SPXGRSTA

LP-7

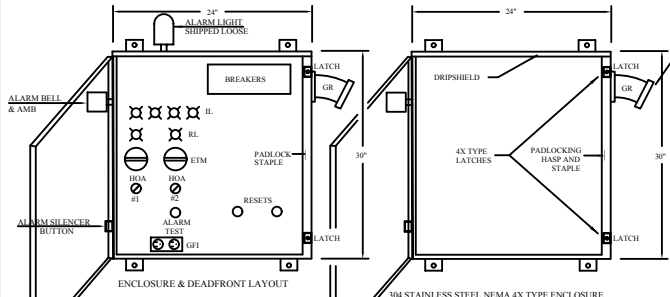

ENCLOSURE & DEADFRONT LAYOUT

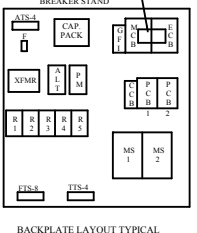

BACKPLATE LAYOUT TYPICAL

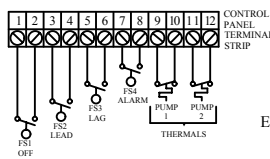

CONTROL PANEL TERMINAL STRIP

- BILL OF MATERIALS**
- ENC 304 STAINLESS STEEL ENCLOSURE
 - MCB MAIN CIRCUIT BREAKER
 - ECB EMERGENCY CIRCUIT BREAKER
 - PCB1,2 PUMP CIRCUIT BREAKER
 - CCB CONTROL CIRCUIT BREAKER
 - GFxCB GEN. CIRCUIT BREAKER
 - MS1,2 STARTER
 - OL HEATER
 - XFMR TRANSFORMER
 - GR GENERATOR RECEPTACLE
 - VM VOLTAGE MONITOR
 - AL ALARM TEST PUSH BUTTON
 - AB ALARM LIGHT
 - AMB ALARM MOUNTING BOX
 - F FLASHER
 - RL RUN LIGHT
 - IL INDICATING LIGHT
 - IL AMBER LENS
 - RED LENS
 - HOA HAND OFF AUTO SWITCH
 - ETM4 ELAPSED TIME METER
 - ALT ALTERNATOR
 - R1-5 CONTROL RELAY
 - F1 FUSE
 - F2 FUSE
 - GF1 CONVENIENCE RECEPTACLES
 - LA LIGHTNING ARRESTOR
 - SC SURGE CAPACITOR
 - ASR START CAP. START RELAY
 - ALM ALARM SILENCE RELAY
 - ES1 3024088HDS W/DRIP SHIELD
 - ES2-D SIZE AS REQUIRED
 - ES3-D SIZE AS REQUIRED
 - ES4-D SIZE AS REQUIRED
 - ES5-D QOU110
 - ES6-D, QOU115
 - ES7-D, S536 (SIZED TO HORSEPOWER)
 - ES8-D, SIZE AS REQUIRED
 - ES9-D, K100
 - ES10 APPLETON, ACR1004BS/AA100 W/SCREW CAP
 - ES11 DIVERSIFIED, L0A-240-ALA
 - ES12 30-D, 900 SKRU
 - ES13 WHEELLOCK-41T-66-1155
 - ES14 W/3 SILVER
 - ES15 SSAC, FS128
 - ES16 DIALCO, 95-5710-09-301
 - ES17 DIALCO, 95-5710-09-301
 - ES18 LITLITE, LITE, 710-AN
 - ES19 LITLITE, 710-RN
 - ES20 30-D, 900 KS-46B
 - ES21 ENM, 15882
 - ES22 DIVERSIFIED, ARB-120-AEA
 - ES23 AA ELEC, AAED12
 - ES24 BUSS, MDL-3
 - ES25 BUSS, MDL-10
 - ES26 LEVITON, 6599-1
 - ES27 INTERMATIC, AG6503
 - ES28 30-D, SDSA3650
 - ES29 TO MATCH GRINDER PUMPS
 - ES30 AA ELEC AAKU144L (BLADE TYPE)

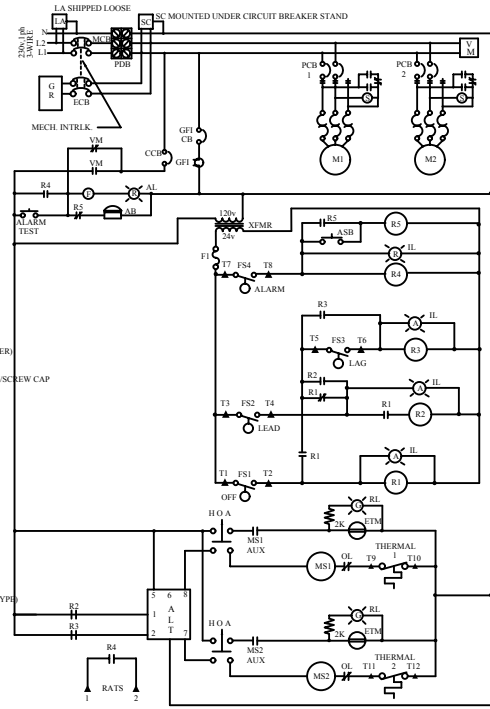

ELECTRICAL CONTROL PANEL SCHEMATIC FOR COMMERCIAL DUPLEX GRINDER PUMP 1PHASE

LOW PRESSURE FORCE MAIN SYSTEM

