

**LOXAHATCHEE RIVER  
ENVIRONMENTAL CONTROL DISTRICT**



**MANUAL OF MINIMUM CONSTRUCTION  
STANDARDS AND TECHNICAL SPECIFICATIONS  
FOR  
LOXAHATCHEE RIVER DISTRICT**

D. Albrey Arrington, Ph.D.  
Executive Director

Kris Dean, P.E.  
Director of Engineering

May 2018

## TABLE OF CONTENTS

<u>SECTION</u>	<u>TITLE</u>	<u>PAGE</u>
1	<a href="#"><u>Administrative and General</u></a>	1-1 to 1-9
2	<a href="#"><u>Design Criteria</u></a>	2-1 to 2-11
3	<a href="#"><u>Miscellaneous Requirements</u></a>	3-1 to 3-3
100	<a href="#"><u>Excavation, Backfill, Fill and Grading</u></a>	100-1 to 100-4
101	<a href="#"><u>Pipe Embedment Material</u></a>	101-1
107	<a href="#"><u>Horizontal Directional Drill</u></a>	107-1 to 107-2
109	<a href="#"><u>Large Diameter PVC Pressure Pipe</u></a>	109-1 to 109-2
111	<a href="#"><u>Ductile Iron Pipe and Fittings</u></a>	111-1 to 111-4
112	<a href="#"><u>Polyvinyl Chloride Gravity Sewer Pipe</u></a>	112-1 to 112-5
113	<a href="#"><u>4" - 12" Diameter Polyvinyl Chloride Force Main Pipe</u></a>	113-1 to 113-3
114	<a href="#"><u>4"-65" High Density Polyethylene Force Main Pipe</u></a>	114-1 to 114-2
120	<a href="#"><u>Concrete Masonry</u></a>	120-1 to 120-5
121	<a href="#"><u>Manholes and Structures</u></a>	121-1 to 121-4
122	<a href="#"><u>Grease Interceptors and Traps</u></a>	122-1 to 122-4
130	<a href="#"><u>Valves and Appurtenances</u></a>	130-1 to 130-5
140	<a href="#"><u>Pipeline Integrity Tests</u></a>	140-1 to 140-5
150	<a href="#"><u>Submersible Lift Stations</u></a>	150-1 to 150-7
151	<a href="#"><u>Low Pressure Sewer Systems</u></a>	151-1 to 151-7
152	<a href="#"><u>Adoption of Standards</u></a>	152-1
161	<a href="#"><u>Variable Speed/PLC Control Panels</u></a>	161-1 to 161-7
162	<a href="#"><u>Generator and ATS</u></a>	162-1 to 162-5
168	<a href="#"><u>Instrumentation</u></a>	168-1 to 168-2
169	<a href="#"><u>Programmable Logic Controller</u></a>	169-1 to 169-5

170

Remote Terminal Unit – Lift Station

170-1 to 170-6

Low Pressure Force Main Details

LP-1 to LP-35

Standard Details

SD-1 to SD-30

Lift Station Details

SD-31 to SD-34

## SECTION 1

### ADMINISTRATIVE AND GENERAL

#### 1.01 General

The purpose of this manual is to provide the minimum construction standards for design and construction work associated with wastewater systems within the District and is intended to supplement the requirements of other regulatory agencies. The design engineer is to use good engineering judgment in the design of wastewater systems. The design engineer and the contractor are responsible for providing sound, workable, and long lasting systems.

The intent of this section is to provide members of the development community with a brief introduction to the Loxahatchee River Environmental Control District, also referred to as “District”, its function, and procedures.

The Loxahatchee River Environmental Control District is an agency of government which was created in 1971 for the purpose of providing utility and other environmental services within the 72 square mile basin of the Loxahatchee River. Currently, the District owns, operates, and regulates the regional wastewater system serving Tequesta, Jupiter, Juno Beach, Juno, and the unincorporated areas of northern Palm Beach and southern Martin Counties.

The District offices are located at 2500 Jupiter Park Drive, Jupiter, Florida. The offices are open between 8:00 A.M. and 5:00 P.M. weekdays. The telephone number during working hours is (561) 747-5700. For emergency situations outside of normal office hours, the telephone number is (561) 747-5708. The District website can be found at <http://www.loxahatcheeriver.org>.

With specific regard to new development, the District’s legislated policy is to provide the required utility services to the area now and as it continues to grow. It is, therefore, the agency’s intent to work closely with new development to assure that the utility services can be provided in a manner which is both timely and consistent with the standards and specifications set forth in this manual.

Please note that the District’s “Manual of Minimum Construction Standards and Technical Specifications” may change from time to time. All projects will be subject to the current District, local, state and federal rules and regulations at the time of submittal of final engineering drawings for approval.

#### 1.02 Procedures Prior to Construction

##### 1.02.1 Introductory Meeting

It is highly recommended that the project representative (s) (owner, engineers) meet with the District’s Deputy Executive Director early in the planning stages of the development. At such time a determination of sewer and reuse water availability will be made, and financial impacts will be reviewed.

### 1.02.2 Developer Agreement

The submittal of a properly executed agreement, along with payment for certain charges, is required before the District will review the engineering plans. Copies of the District's Standard Developer Agreement and Chapter 31-10 F.A.C., which addresses the charges, are available online or at the District offices.

### 1.02.3 District Installed Facilities

During the introductory meeting the developer may wish to discuss the availability of District installed regional and sub regional facilities to serve the proposed project, although, this program is limited to larger developments.

The District currently maintains a program where sub regional lift stations may be constructed by and paid for by the District. A sub regional facility must be designated and approved by the District Governing Board. Staff will take no action for recommending designation of a facility for installation until a developer agreement is executed and all fees are paid.

Staff reviews and assesses the project based upon economic feasibility, consistency with the District Master Plan and its current and future demand. To promote stable and effective communication between the District and the Developer, we will require the Developer to coordinate all communication through the Engineer of Record.

In designating a sub-regional facility, the following items are the responsibility of the owner/developer:

Provide the District with any project information necessary for the design of lift station(s) and force mains(s).

Provide, at developer's expense, all necessary electrical service to the lift station site in conjunction with construction activities.

Provide suitable access to lift station and force main sites for District and contractor's vehicles and equipment. Paved asphaltic concrete or reinforced concrete access drives will be provided (Min.16' wide) prior to acceptance.

Provide appropriately sized sanitary sewer gravity lines that are necessary to serve adjoining properties in conjunction with lift station construction. Sewer lines to adjoining properties must be activated concurrent with lift station, or upon demand from the District.

The last collection manhole, just upstream of the lift station, should be placed in a manner to minimize road, lane or sidewalk closures should by-pass operations be

needed at the lift station. The District may require this last collection manhole to be placed inside the lift station easement.

Provide all clearing, grubbing and rough grading of the lift station and force main sites prior to construction.

Provide survey requirements and staking of the lift station and force main upon request from the District. Staking shall include provision of one stake at center of the proposed wet well, with 50' offsets and bench mark. Force main shall be staked at center line with 10' offsets every 100 feet, with a set bench mark. All survey work shall be performed by a professional surveyor licensed in the State of Florida.

Developer shall convey a deed to the lift station property prior to construction, and all required easements as follows:

Permanent Easements:

- a. Lift Station - 40' x 40'
- b. Force Mains - 10' wide minimum
- c. Gravity Mains - 15' wide minimum for sewers

Temporary Construction Easements:

- a. Lift Station - 100' x 100'
- b. Force Mains - 30' wide minimum
- c. Gravity Mains - 50' wide minimum

Developer's contractor will be responsible to make gravity line connections from the system collection manhole to the lift station after the construction of the wet well has been completed.

District staff will work in conjunction with the developer's project engineer to plan for the service area. Station design will be performed by the District. Construction will be contracted for by the District and inspected by District personnel.

#### 1.02.4 Developer Installed Facilities - Plan Review and Approval

An initial electronic plan submittal (PDF) is recommended. Submittal should contain; one (1) complete set of plans including sewer, reuse, water and drainage systems, and paving and grading details. Upon review, the design engineer will be notified of acceptance or comments which need to be addressed. District staff will work with the Developer's Engineer of Record to address the final design of Developer installed facilities.

Final submittal for approval will require additional plan sets, to include one electronic (PDF), two (2) hardcopy full-size (24x36) sets for District files, four (4) sets for Florida Department of

Environmental Protection and/or Palm Beach County Health Department, plus any additional sets required by the engineer or owner.

District approval of utility plans and specifications, as well as sign off on the Florida Department of Environmental Protection/Health Department application, is required.

Plan review will be for technical sufficiency of design for incorporation into the District system. This review, as well as plan approval by the District, does not relieve the design engineer of his liabilities or responsibility for a properly detailed design. District Engineering staff will be available to work with the design engineer to assure the plans meet the requirements set forth in this manual.

All plan submittals must be signed and sealed by a Professional Engineer, registered in the State of Florida. Plans which are marked "Preliminary" or "Draft" will not be approved.

Supplemental data to be furnished with the final plans submitted for approval includes the following:

1. Project Summary
  - a. Number of residential units being served or non-residential uses.
  - b. Number of Manholes
  - c. L.F. of Gravity Main (for each pipe size)
  - d. L.F. of Force Main (for each pipe size)
  - e. Number of Lift Stations and depth of each
2. Basis of determination of design capacity and design flow.
3. Calculations and plot of system head curves.
4. Calculations of pump cycle times.
5. Wet well floatation calculations.
6. Landscaping plan that includes the proposed sewer facilities on the plan to determine if the necessary setbacks are provided.
7. Preliminary phasing plan (for entirety of project) that includes a table indicating number and type of lots (i.e., multifamily, single family, etc.) and the year those lots require DOH certifications.

1.03            Developer Installed Facilities - Procedures During Construction



### 1.03.1 Periodic Inspection

Throughout construction, the developer will look to his consulting engineering firm for progress by periodic inspections. District Engineering staff will periodically check the site during construction for progress. If problems are encountered during construction, it will be the developer's responsibility through his engineers, to resolve them to the District's satisfaction. Any revision of substance to the approved plans shall be submitted to the District for approval prior to incorporation into the work.

### 1.03.2 Pre-Final Inspection Submittals

1. Approximately 60 days prior to construction completion, the Developer's Engineer of Record shall provide the Deputy Executive Director the following for review and approval:
  - a. A signed and sealed cost of construction of the sewer improvements. This information will be used to establish the value of the maintenance bond.
  - b. A final Phasing Plan. The Phasing Plan should encompass the project in its entirety and is solely at the discretion of the District as to timing and extent of phases.
2. Upon receipt of the above information the Deputy Executive Director will prepare a letter to the Owner, with copy to the engineer, with the Bill of Sale and easement forms prepared for execution, along with a listing of administrative items to be provided prior to District inspection of facilities for acceptance.

### 1.04 Developer Installed Facilities - Procedures Following Construction

#### 1.04.1 Project Completion

A project is not considered complete and prepared for District final inspection until such time as:

1. All sewer system construction is completed in accordance with plans and specifications and inspected and certified by the engineer.
2. Where sewers are constructed in paved areas, at least the 1<sup>st</sup> lift of asphalt has been provided.
3. Areas over lines and laterals, which are not proposed to be paved, shall be brought to finish compacted grade.

#### 1.04.2 Project Completion Submittals

Upon Completion of Construction, but before District final inspection, submit the following items in forms acceptable to the District:

1. Bill of Sale
2. Grant of Easement
3. Maintenance Bond: From a surety company and executed by an attorney-in-fact for the surety company with a certified copy of his Power-Of Attorney attached to the Bond; or a
4. Letter of Credit: From a financial institution and in a form acceptable to the District.
5. Record Drawings: Submit one (1) blackline copy of the record drawings, signed and sealed by a Florida licensed Professional Surveyor & Mapper. Record drawings must comply with LRD's standard detail SD-29 "Record Drawing Submittal Guide".
6. Department of Environmental Protection Certificate of Completion Executed by Owner and Certifying Engineer.
7. Letter of Certification from the Engineer of Record
8. Performance Test Results: infiltration/exfiltration, pressure, leakage and pump start-up test records. All documents must be signed and sealed by the Engineer of Record.
9. Copy of Site Plan and Recorded Plat indicating all building numbers and street names.
10. Payment for all buildings connected to the system.

#### 1.04.3 Final Inspection

After the owner and project engineer have provided the documents as outlined in Section 1.04.2, and all punch list items have been remedied, the District engineering staff will conduct a final inspection and recommend acceptance or denial. If acceptance is denied, a letter will be sent to the project engineer advising of the denial and reasons for such. Subsequently, the project engineer should address the comments and request scheduling a final reinspection. It should be noted that after the final inspection, any comments to the initial Record Drawing submittal shall be provided to the Engineer of Record for any remedies.

#### 1.04.4 Final Record Drawings

After District Engineering staff has completed the final inspection and all work is to the satisfaction of the District Engineer, the final Record Drawings shall be submitted to the District, as follows:

1. Two (2) final black line record drawings, signed and sealed by a Florida licensed Professional Surveyor & Mapper. This record drawing shall meet the technical standards

for “Record Survey” set forth by the Florida Board of Professional surveyors and mappers, pursuant to Chapter 472 of the Florida Statutes and Chapter 61G17-6, Florida Administrative Code.

2. One (1) compact disc with the record drawing in AutoCAD 2008 or later format and PDF format. Only one (1) AutoCAD file shall be accepted containing the entire record drawing (additional files used for x-referencing are acceptable) and one Adobe Acrobat file with the entire record drawing as seen on the paper copy. The District will no longer accept separate AutoCAD and/or Adobe Acrobat files for separate record drawing pages. The AutoCAD files must be established in state plane coordinate system, NAD 83, Florida East Zone. The vertical datum referenced shall be NGVD 29.

#### 1.04.5 One Year Maintenance Bond and Inspection

Prior to acceptance by the District, a maintenance bond which will remain in effect for one year from the date of District acceptance of the system, must be provided to the District. Shortly before the expiration of the one-year maintenance bond, the District will reinspect the system in a manner similar to the final inspection (i.e., broken pipes, deflection, infiltration, etc.) The District will advise the developer of any defects found, unless of an emergency nature, during this inspection and will require correction to be made prior to expiration of the maintenance bond.

Should adequate progress, in the opinion of the District, not be made in correcting the deficiencies, the District will look to the bonding company to pay for corrective action taken by the District.

A Letter of Credit drawn upon a financial institution licensed in the State of Florida, and in a form acceptable to the District may be provided in lieu of a maintenance bond.

#### 1.04.6 District Acceptance

Upon satisfactory finding of the final inspection, the Department of Environmental Protection/Health Department Certification of Completion will be executed by the Executive Director, thereby, accepting the system for operation and maintenance.

#### 1.04.7 Operation and Maintenance

With the exception of service laterals which lie beyond right-of-way or easement lines, or in common areas of ownership, the wastewater system serving the development will be operated and maintained by the District’s personnel, who are well trained and responsive to the needs of the community.

#### 1.04.8 Utility Billing

The District’s accounting department will continue to work with the Developer in the collection of connection charges as new buildings are tied into the system, and in the billing of quarterly service charges.

1.05            Definitions and Abbreviations

The term “Owner” or “District” shall mean the Loxahatchee River Environmental Control District.

The term “Director” shall mean the Executive Director of the Loxahatchee River Environmental Control District.

The term “Engineer” or “Design Engineer” shall be the engineer registered in the State of Florida that signs and seals the plans of a developer or other person or entity.

The term “District Engineer” shall be the engineer designated by the District, whether acting directly or as an authorized agent of the District, acting within the scope of duties entrusted to them.

The abbreviation listed below shall have the meaning set forth opposite each:

AASHTO	American Association of State Highway Transportation Officials
ACI	American Concrete Institute
ANSI	American National Standards Institute
ASCE	American Society of Civil Engineers
ASTM	American Society for Testing and Material
AWWA	American Water Works Association
NEC	National Electric Code
NEMA	National Electric Manufacturers Association
AWG	American or Brown and Sharpe Wire Gage
NPT	National Pipe Thread
WOG	Water, Oil, Gas

**END OF SECTION 1**

## **SECTION 2**

### **DESIGN CRITERIA**

#### 2.01           General

The requirements of this section are a minimum and nothing herein shall be construed to eliminate consideration of a design based on a rational procedure not covered by such requirements. Standards or minimum requirements set forth in this Manual are not intended to relieve the Developer, Contractor, or Design Engineer from complying with good engineering and construction practices under specific conditions which require a higher degree of procedure, standards, or requirements. Where the Developer, Contractor, or Design Engineer is not capable of following the requirements of the Manual due to certain site conditions, any deviation from the requirements set forth in the Manual shall first be approved by the District. It is intended that the requirements of this section shall be applicable in all cases where the facilities being constructed or to be constructed shall be owned and/or operated and maintained by the District.

#### 2.02           Design Capacity

Gravity sewer systems should be designed for the estimated ultimate tributary population. Parts of the system that can be readily increased in capacity such as lift stations may be submitted for approval based on phased implementation. The basis of design for all projects shall accompany the plan documents.

#### 2.03           Design Flow

Sewer system Average Daily Flow (ADF) designs shall be based on the design flows as listed in Chapter 64E-6 of the Florida Administrative Code.

##### 2.03.1        Peak Hourly Flow

Peak Hourly Flow (PHF) shall be utilized for the sizing of all gravity sewers, force mains and lift station pump sizing. Peak hourly flow peaking factor (Pf) shall follow Figure 1 - Ratio of Peak Hourly Flow to Design Average Flow, of the “Recommended Standards for Wastewater Facilities”, by the Waste Water Committee of the Great Lakes – Upper Mississippi River Board of State and Provincial Public Health and Environmental Managers, latest edition.

For low pressure sewer systems, all low pressure mains and LRD’s approved grinder pump systems (centrifugal) shall be sized based upon the estimated peak design flow. The estimated peak design shall follow either Part 4 – Design Flows, of the “Design and Specification Guidelines for Low Pressure Sewer Systems”, by the FDEP, latest edition or Chapter 2, “Manual – Alternative Wastewater Collection Systems”, by the EPA, latest edition.

2.04            Gravity Sewers

2.04.1        New Construction

The basic design criteria for gravity sewers shall be as follows:

Pipe material – all new gravity sewer shall be of PVC construction. Use of epoxy coated D.I.P. will only be allowed with prior approval from the District Engineer.

The minimum gravity sewer pipe line diameter – All new gravity sewer mains (manhole to manhole) shall be a minimum of 8-inches in diameter.

The minimum depth of cover shall be as follows: 3'-6" for DIP or PVC C-900 and 4'-0" for PVC SDR-26. Any cover that is proposed to be less than 4'-0" must be given prior approval by the Director of Engineering.

Straight alignment and constant slope between manholes.

All manholes shall be precast concrete with monolithic bases and concentric conical cone sections.

Manholes are required at the end of each line; at all changes in grade, size or alignment. Stubs eight (8) inches or larger will require a manhole at the terminus point.

Manholes shall be spaced not greater than 400 feet for sewers fifteen (15) inches in diameter or less, 450 feet for sewers eighteen (18) inches in diameter or greater.

Five-foot drop manholes (internal type) are to be provided for a sewer entering a manhole at an elevation twenty-four 24 inches or more above the lowest manhole channel invert. (See Standard Details)

A positive 0.1-foot grade differential shall be provided between the upstream and downstream invert on all manholes.

All sewers shall be designed and constructed to give mean velocities, when flowing full, of not less than 2.0 feet per second, based on Kutter's formula using an "n" value of 0.013. The following are minimum slopes allowed:

<u>Sewer Size</u>	<u>Slope in Ft/100 Ft</u>
8-inch	0.40
10-inch	0.28
12-inch	0.22
15-inch	0.15
18-inch	0.12
21-inch	0.10
24-inch	0.08
27-inch	0.067
30-inch	0.058
36-inch	0.046

When possible, slopes at least 10% above the minimums shown are preferred. However, in no case will slopes be designed which would provide a mean velocity less than 2.0 feet per second when flowing full, based on an “n” value of 0.013.

When a smaller sewer joins a larger one, the invert of the larger sewer should be lowered sufficiently to maintain the same energy gradient. An approximate method for securing these results is to place the 0.8 depth point of both sewers at the same elevation.

Intersecting sewers shall not meet at an alignment angle of less than 90 degrees to downstream flow.

Manholes deeper than 14 feet from the lowest invert to the manhole rim, manholes with a force main discharge, manholes with inside drops and the last collection manhole just upstream of a lift station, shall be given a minimum 0.5-inch coat of Sewper Coat, Strong Seal, Refratta HAC 100 or other approved calcium aluminate corrosion barrier.

The last collection manhole, just upstream of the lift station, should be placed in a manner to minimize road, lane or sidewalk closures should by-pass operations be needed at the lift station. The District may require this last collection manhole to be placed inside the lift station easement.

All gravity sewers shall be placed in the center of any roadway and within any easements. The minimum gravity sewer easement is 15’ wide.

No landscaping or surface features (i.e., walls, fences, fountains, etc.) shall be placed in a manner that would adversely affect access to utility easements or District infrastructure. Trees shall be a minimum of 10’ away from any gravity sewer main or service line/lateral. This may be reduced to 7’ with the use of an approved root barrier system.

All gravity sewer mains shall be a minimum of 10' horizontally from any structures. This setback shall be measured from the outside edge of the pipe to the nearest part of the structure, including underground (i.e., footers) or above ground (i.e., roof overhangs) features.

In addition to the above requirements, gravity sewer design shall follow Recommended Standards for Wastewater Facilities, at a minimum.

#### 2.04.2 Adjustments to Existing Sewer Infrastructure

There may be instances where an area is being redeveloped or when a new developer takes ownership of a project from a previous developer and wishes to make modifications to already constructed, but not yet activated sewer facilities. The following criteria shall apply:

It is advised that developers of redesigned projects meet with the District Engineer to conduct a pre-application meeting and/or conduct due diligence prior to submitting final engineering plans to discuss the proper procedure for obtaining approval for any modifications.

This manual is updated from time to time, thus any comments provided at a pre-application/due diligence meeting should be considered conceptual in nature and may no longer be applicable by the time final engineering drawings are submitted to the District for approval (See Section 1.01).

Services may be abandoned on a gravity run (manhole to manhole) and the service must be entirely removed, including the mainline wye fitting. The repair(s) must be completed using one two sleeves and one spool piece per abandoned service.

Lift stations and all related appurtenances must be brought up to current LRD standards if they haven't been installed.

LRD will accept all gravity and force mains as constructed and re-inspect them based upon the LRD standards at the time the project was approved. However, additional appurtenances may be required to be installed, such as air release/vacuum valves or inline valves should the District Engineer require them. Additionally, all setbacks shall be based upon the current LRD standards.

LRD will accept all previously agreed to sewer easement widths, though the extent of the easements may require modifications should any infrastructure be removed or added.

Any new infrastructure proposed by the new developer shall meet all current LRD standards.



2.05            Pumping Stations

The basic design criteria for pump stations are as follows:

Sized to handle the peak hourly flows from the tributary areas with the largest pumping unit out of service (firm capacity).

Total dynamic head based on static head, lift station friction losses and pipeline friction factor (C) of 120. Pumping units shall be capable of operating based on a C=100 and not “running out” based on a C=140.

Pumping units capable of passing spheres of at least three (3) inches in diameter.

Under normal conditions, pumps operate under a positive suction head.

Controls included to automatically alternate the pumps in use.

Maximum pump speed of submersible pumps shall not be greater than 1800 rpm unless specifically allowed by the District Engineer. The maximum pump speed of other raw wastewater pumps shall be 1150 rpm unless specifically allowed by the District Engineer.

Four types of pump stations are considered for use in the District. The pump station types are as follows:

Level I &	
Level II	Submersible
Level III	Built in place - constant or variable speed pumps
Level IV	Built in place - variable speed pumps.

Typical application of the various pump station types is shown on Figure 2-1, page 2-11.

All electrical and mechanical equipment to be protected from physical damage by a 100-year flood.

Lift stations shall be provided with remote telemetry (Data Flow Systems radio telemetry or cellular telemetry) and wetwell level instrumentation.

Detailed specifications and drawings for Level I – IV pump stations and appurtenances are included elsewhere in this manual. Site specific designs and requirements not covered under this manual will be reviewed on a case by case basis. Additional design criteria for these stations are contained in the “Recommended Standards for Wastewater Facilities”, by the Water Supply

Committee of the Great Lakes – Upper Mississippi River Board of State and Provincial Public Health and Environmental Managers, latest edition.

All wet wells shall be designed to resist flotation at times of the highest groundwater and/or the 100-year flood (whichever is greater) at the site, without consideration of the weight of the pumps, with a safety factor of at least 1.0. Flotation calculations based on a unit weight of concrete of 130 pounds per cubic foot shall be submitted to the District for review with all pump station plans

Wet well cycle times shall be 10 minutes minimum 30 minutes maximum; based on the formula:

$$T = \frac{V}{Q-S} + \frac{V}{S}$$

Where:

- T = Cycle time (minutes)
- V = Effective volume of wet well (gallons)
- Q = Pumping rate (gpm)
- S = Average daily flow (gpm)

All lift stations shall be given a 1.0-inch coat of Sewper Coat, Strong Seal, Refratta HAC 100 or other approved calcium aluminate corrosion barrier.

## 2.06 Force Main

The basic design criteria for force mains are as follows:

Pipe material – C-900 PVC, epoxy lined ductile iron pipe or HDPE (DR-11 min).

Minimum size - 4-inch diameter.

Minimum velocity - 2 feet per second.

Maximum velocity - 8 feet per second.

Minimum depth of cover - 3 feet.

Branches of intersecting force mains shall be provided with appropriate valves such that one branch may be shut down for maintenance and repair without interrupting the flow of other branches. Stubouts on a force main, placed in anticipation of future connections, shall be equipped with a valve to allow such connections without interruption of service.

At all times, the force main shall be laid level and per the design elevations approved by the District. An automatic air release valve shall be placed at all high points of all force mains with a diameter of (4) inches or larger, as indicated on the construction plans and approved by the District.

All automatic air release/air vacuum valves shall be placed in a manhole as provided in the District's standard details.

Force main design drawings are to indicate elevations at all high points and all low points with constant slopes in between such points. Low point drains should be placed at all low points in the force main profile.

Approved restrained joints shall be provided at all force main bends.

Terminal ends of force main (permanent or temporary) shall be as shown on the Standard Details.

## 2.07            Separation Requirements

Storm and sanitary sewers crossing under water mains shall be laid to provide a minimum vertical distance of twelve inches between the invert of the upper pipe and the crown of the lower pipe. Where this minimum separation cannot be maintained, the crossing shall be arranged so that the sewer pipe joints and water main joints are equidistant from the point of crossing with no less than ten (10) feet between any two joints and both pipes shall be D.I.P. Where there is no alternative to sewer pipes crossing over a water main, the criteria for the minimum separation between lines and joints in the above, shall be required and both pipes shall be D.I.P. irrespective of separation. D.I.P. is not required for storm sewers. Vertical separations of less than (12) inches, will not be accepted.

Where storm sewers cross above or below sanitary sewer mains, the minimum vertical separation between the outside of the storm sewer main and the outside of the sanitary sewer main is (12) inches. Where the minimum separation cannot be maintained, the sewer main shall be constructed of C-900, DR-18 PVC at the conflict with one full joint (min. 20 feet) centered on the conflict. Vertical separations of less than 6 inches, will not be accepted.

The minimum vertical separation between sanitary sewer mains and any other utility other than those listed above is 12 inches. Vertical separations of less than 12 inches, will not be accepted.

Maintain 10 feet horizontal distance between water mains, storm pipes and sanitary sewer mains unless reduced separation is allowed by the FDEP, Palm Beach County Health Department and the District Engineer. Separations greater than ten feet may be required for drainage pipes larger than 48" in diameter.

2.08            Sewer Use Regulations

The Loxahatchee River Environmental Control District has adopted certain rules and regulations regarding the acceptability and pretreatment requirements for certain types of wastewaters. These rules and regulations are published in Chapter 31-13 of the District Rules and may be amended from time to time. Prospective users of the system should contact the District Deputy Executive Director for information regarding the above referenced rules and the Director of Operations for compatibility of the anticipated wastewater with the District's facilities.

**END OF SECTION 2**

## MISCELLANEOUS REQUIREMENTS

### 3.01 Lines, Grades and Measurements

Alignment and grade of all pipe, tunnels and borings shall be continuously controlled by use of lasers or other acceptable method. Laser alignment and grade through the pipeline is the preferred method. The District Engineer shall be permitted at any time to check the lines, elevations, reference marks, laser, etc., set by the Contractor or the Design Engineer.

### 3.02 Work to Conform

The maximum allowed vertical deviation of any single gravity pipe, tunnel or boring from plan grade shall be three percent (3%) of inside diameter. No single gravity pipe shall vary in horizontal alignment right or left, from the pipe centerline by more than five percent (5%) of inside diameter. Force main joint deflections shall be limited by AWWA Standards and manufacturer's recommendation.

### 3.03 Pipeline location

Pipelines shall not be located closer to an existing or proposed structure than the horizontal distance obtained when drawing a 45-degree angle from the proposed invert of the pipeline to bottom outside face of the footing. In no case shall this distance be less than ten (10) feet. Pipelines shall be located as indicated on the drawings, but the Design Engineer is responsible to make such modifications in location as may be found desirable to avoid interference with existing structures or for other reasons, which are not material to the interest of the District and which do not otherwise conflict with any other statement or criteria set forth in this manual. The District should be notified of such changes in a timely fashion and such changes shall be recorded on Record Drawings.

### 3.04 Pipe Adapters

When joining pipes of different types, District approved transition sleeves, adapters, and couplings shall be used.

### 3.05 Fittings and Stoppers

Branches, stub-outs and fittings shall be laid as indicated in the Standard Details and shown on the approved drawings. Open ends of pipe and branches shall be closed with nonmetallic "wing nut" expansion stoppers secured in place in an acceptable manner. Stoppers shall be designed to remain in place and watertight during infiltration tests.

### 3.06 Service Lines

#### a. General

Service lines shall be as shown on the Standard Details. Service lines for a single building structure shall be minimum of 4 inches in diameter; for two building structures, a minimum of 6-inches in diameter. Where three or more building structures are connected to a single service line, the service line shall be considered a gravity sewer, shall be minimum of 8-inches in diameter, and shall be in accordance with the criteria covering District maintained gravity sewers.

If a residential property requires an easement across another residential property to gain access to District sewers this easement shall be conveyed to the District. This shall only be allowed when agreed to in writing by the District engineer.

b. Maintenance Responsibility

The service line (lateral) cleanout will usually delineate the point of responsibility between the District and the property owner; however, the following variations do exist:

1. Multi-family Units - Public right-of-way - Owner's responsibility to the right-of-way line.
2. Multi-family Units - Non-Public right-of-way - Owner's responsibility to the main line connection.
3. Commercial Buildings - Owner's responsibility to the main line.
4. Condominium with Common Areas - Non-Public right-of-way Owner's responsibility to the main line connection.
5. Condominium with Common Areas Adjacent to Public right-of-way - District assumes responsibility within the public right-of-way.

3.07 Service Line Markers

A service line marker shall be installed 12-inches {minimum} above the service wye adjacent to the cleanout of each service line. The service line markers shall be Electronic System, Sanitary Marker 1258, as manufactured by 3M.

3.08 Bolts, Anchor Bolts, and Nuts

Anchor bolts shall have suitable washers and, where so required, their nuts shall be hexagonal. All anchor bolts, nuts, washers, plates, and bolt sleeves shall be galvanized unless otherwise indicated or specified.

Expansion bolts shall have malleable iron and lead composition elements or the required number of units and sizes.

Bolts, anchor bolts, nuts and washers specified to be stainless steel shall be type 316 stainless steel.

Anchor bolts and expansion bolts shall be set accurately. If anchor bolts are set before the concrete has been placed, they shall be carefully held in suitable templates of approved design. If anchor or expansion bolts are set after the concrete has been placed, all necessary drilling and grouting or caulking shall be done, and care shall be taken not to damage the structure or finish by cracking, chipping, spalling, or otherwise during the drilling and caulking.

3.09            Concrete Inserts

Concrete inserts shall be designed to safely support the maximum load that can be imposed by the bolts used in the inserts. Inserts shall be of a type which will permit locking of the bolt head or nut. All inserts shall be galvanized.

3.10            Protection against Electrolysis

Where dissimilar metals are used in conjunction with each other, suitable insulation shall be provided between adjoining surfaces so as to eliminate direct contact with any resultant electrolysis. The insulation shall be bituminous impregnated felt, heavy bituminous coatings, nonmetallic separators or washers, or other approved materials.

**END OF SECTION 3**

## SECTION 100

### EXCAVATION, BACKFILL, FILL AND GRADING

#### 100.01 Description

All excavations shall be made in such manner and to such widths as will provide suitable room for building the structures or laying and jointing the piping. All sheeting, bracing, supports, coffer dams, pumping and draining shall be performed to render the bottom of the excavations firm, dry and acceptable in all respects.

#### 100.02 Sheeting and Bracing

Sheeting and bracing shall be furnished as may be necessary to support the sides of the excavation and to prevent any movement of earth which could in any way diminish the width of the excavation to less than that necessary for proper construction, or could otherwise injure or delay the work, or endanger adjacent structures.

All timber sheeting and bracing shall be left in place unless otherwise directed by the Design Engineer to remove same or cut off at a specified elevation.

All sheeting and bracing, including trench boxes not to be left in place, shall be carefully removed in such manner as not to endanger the construction or other structures. All voids left or caused by the withdrawal of sheeting shall be backfilled immediately with approved material and compacted by ramming with tools especially adapted to that purpose, by watering, or by other means as may be directed by the Design Engineer.

#### 100.03 Drainage

##### 100.03.01 General

To ensure proper conditions at all times during construction, all means shall be used to intercept and/or remove promptly and dispose properly of all water entering trenches and other excavations. Such excavations shall be kept dry until the structures, pipes and appurtenances to be built therein have been completed to such extent that they will not be floated or otherwise damaged.

All water pumped or drained from the work shall be disposed of in a suitable manner without undue interference with other work, damage to pavements, other surfaces, or property. Suitable temporary pipes, flumes, or channels shall be provided for water that may flow along or across the site of the work. All requirements of all regulatory agencies regarding dewatering and the discharge of water from the project shall be complied with.

All labor, materials, tools, and equipment shall be provided, as necessary, to properly control the quality of the discharge from the dewatering operations as described herein. All applicable laws, rules and regulations governing the discharge of water from dewatering operations shall be



complied with. All dewatering shall be accomplished by the use of sanded well points and other techniques deemed necessary by the Contractor to properly dewater the trench excavations.

The water discharged from the Contractor's dewatering operation shall not exceed the turbidity limits promulgated by the State of Florida Department of Environmental Protection discharge standards for the Loxahatchee River or its tributaries.

Unless otherwise directed by the Design Engineer, an approved siltation tank shall be installed ahead of dewatering discharge points. In addition, silt screens and other devices and techniques may be required to maintain the discharge quality at turbidity levels below the required limits.

Any and all methods approved by the Design Engineer to control the bacteriological quality of well point discharge into existing drainage ditches and/or canals shall be utilized. Levels for fecal coliform in a discharge which ultimately leads to the Loxahatchee River, shall not exceed those promulgated by the State of Florida Department of Environmental Protection discharge standards.

#### 100.03.02 Drainage Well-point System

If it is necessary to drain the soil and prevent saturated soil from flowing into the excavation, an efficient drain well-point system will be utilized. The well points shall be designed especially for this service. The pumping unit shall be designed for use with the well-points and shall be capable of maintaining a high vacuum and of handling large volumes of air and water at the same time.

#### 100.04 Trench Excavation

Where pipe is to be laid in rock bedding or concrete cradle, the trench may be excavated by machinery to, or to just below, the designated subgrade, provided that the material remaining at the bottom of the trench is not disturbed.

If the trench is excavated below the designated subgrade, the undercut shall be backfilled with compacted bedding rock, uniformly graded from ¼-inch size.

#### 100.05 Depth of Trench

Trenches shall be excavated to such points as will permit the pipe to be laid at the elevations, slopes, or depths of cover indicated and at uniform slopes between indicated elevations.

#### 100.06 Width of Trench

Pipe trenches shall be made as narrow as practicable and shall not be widened by scraping or loosening materials from the sides. Every effort shall be made to keep the sides of the trenches firm and undisturbed until backfilling has been completed and consolidated.

Trenches shall be excavated with approximately vertical sides between the elevation of the center of the pipe and an elevation one (1) foot above the top of the pipe.

#### 100.07 Trench Excavation in Fill

If pipe is to be laid in embankments or other recently filled material, the material shall first be placed to the top of the fill or to go to a height of at least three (3) feet above the top of the pipe, whichever is the lesser, Particular care shall be taken to ensure maximum consolidation of material under the pipe location, The pipe trench shall be excavated as though in undisturbed material.

#### 100.08 Unauthorized Excavation

If bottom of any excavation is taken out or disturbed beyond the limits indicated or prescribed, the resulting void shall be backfilled with embedment material compacted to a minimum of 90% of AASHTO T-180 or to the standards of the applicable agency having jurisdiction.

#### 100.09 Elimination of Unsuitable Material

Pipe bedding shall extend a minimum of 4 inches below the pipe. The pipe shall be supported on suitable material ascertained by the Design Engineer following good engineering practices.

#### 100.10 Backfilling

As soon as practicable after the pipes have been laid, or the structures have been built and are structurally adequate to support the loads, including construction loads to which they will be subjected, the backfilling shall be started and thereafter it shall proceed until its completion.

##### 100.10.1 Backfill Materials

The nature of the materials will govern both their acceptability for backfill and the methods best suited for their placement and compaction in the backfill. The materials and the methods shall both be subject to the approval and direction of the Design Engineer. No stone or rock fragment larger than 3 inches in greatest dimension shall be placed in the backfill nor shall large masses of backfill material be dropped into the trench in such a manner as to endanger the pipeline. If necessary, a timber grillage shall be used to break the fall of material dropped from a height of more than 5 feet. Pieces of bituminous pavement shall be excluded from the backfill unless their use is expressly permitted, in which case they shall be broken up as directed.

##### 100.10.2 Embedment Materials

These materials are described in subsequent sections of this Manual. The use and placement of these materials are indicated on the Standard Details and specified herein.

100.10.3      Zone Around Pipe

The zone around the pipe shall be backfilled with the materials and to the densities and limits indicated on the details.

100.10.4      Compaction

Compaction shall be accomplished by tamping, or under appropriate construction techniques to achieve the required densities.

100.10.5      Maximum Density

Unless specified otherwise, the percent of maximum density referred to in these specifications refers to the maximum density obtained when the material is laboratory tested in accordance with the procedures outlined in Designation AASHTO T-180, Latest Revision or as otherwise required by the governmental agency having jurisdiction over the finished roadway. Field densities shall be determined by a testing laboratory using accepted methods.

100.10.6      Miscellaneous Requirements

Whatever method of compacting backfill is used, care shall be taken that stones and lumps shall not become nested and that all voids between stones shall be completely filled with fine materials. Only approved quantities of stones and rock fragments shall be used in the backfill.

All voids left by the removal of sheeting shall be completely backfilled with suitable material, thoroughly compacted.

**END OF SECTION 100**

## SECTION 101

### PIPE EMBEDMENT MATERIALS

#### 101.01 General

Pipe embedment materials, as specified herein, shall be installed as shown on the details and/or as specified.

#### 101.02 Class 1 Materials (Bedding Rock)

The material shall be ¾-inch to ¼-inch graded material such as coral, crushed stone, crushed shells or bedding rock, well graded in size, 100% passing a 1 inch sieve opening, and as specified in ASTM 57. The bedding rock shall consist of clean hard and durable particles or fragments, free from dirt, vegetable or other objectionable matter. Samples and gradation analysis shall be approved by the Design Engineer before any material is delivered to the job site.

#### 101.03 Class 2 Material

The material shall be well graded, clean course sand and gravels with a maximum particle size of ¾ inch, containing a small percentage of fines and free of organic and other deleterious matter.

#### 101.04 Class 3 Material (Select Backfill)

The material shall be fine sand and clayey gravels, including fine sands, sand-clay mixtures and gravel-clay mixtures, free of organic and other deleterious matter.

#### 101.05 Placing and Compacting

The material shall be spread in layers of uniform thickness and installed to the densities and where shown on the Standard Details or as required.

After each pipe has been brought to grade, aligned and placed in final position, the embedment material shall be deposited and densified under the pipe haunches on each side of the pipe. Following this operation, the remainder of the embedment material shall be installed as shown on the Standard Details and as specified herein.

**END OF SECTION 101**

## SECTION 107

### HORIZONTAL DIRECTIONAL DRILL

#### 107.01 General

This specification covers installation of 4" and larger diameter HDPE pipe using horizontal directional drill methods. Installations shall comply with FDOT Standard Specification (Latest Edition) Section 555, ASTM F1962 and this specification.

#### 107.02 Material and Equipment

The drilling fluid shall be a bentonite drilling fluid with or without polymer additives. All materials shall be NSF/ANSI 60 certified.

Pipe and fittings shall comply with Section 114.

Locating/Tracking/Steering equipment for installations across open water shall utilize a magnetic tracking system utilizing a DC or AC current and a surveyed surface loop coil. Locating/Tracking/Steering equipment in other locations shall require a walk-over tracking system. The locating/tracking/steering equipment shall place the pilot bore with a maximum horizontal tolerance of +/- 5% of directional bore pipe depth below grade.

All directional drills shall be installed with a minimum 2" HDPE conduit and two minimum 10 gauge tracer wires installed for the full length of the bore. The conduit shall be terminated in a CDR box installed at each end of the bore. The 10-gauge tracer wires shall be terminated in the valve box for the isolation valves on each end. The conduit diameter and wall thickness shall be sized to withstand anticipated pull back forces of the installation. Tracer wire shall be high strength copper clad steel, Copperhead Soloshot EHS or approved equal.

#### 107.03 Submittals

Submit technical data, cut sheets and shop drawings for equipment and materials including but not limited to drilling fluid (including MSDS Sheet), additives, pipe, fittings, adapters, pipe stiffeners, bore plan, locating and tracking equipment, locating tracking equipment calibration, locating and tracking equipment certification, heat fusion technician certification and proposed sequence of construction for approval by the Engineer.

Horizontal and vertical alignment of the pilot bore based on location information from the locating/tracking/steering equipment outlined in paragraph 107.02 and surveyed points on the DC surface looped coil. The horizontal and vertical alignment shall be referenced to horizontal and vertical datum requirements as specified in the Record Drawing Submittal Guide, Standard Detail SD-29. **The horizontal and vertical alignment shall be as-built and certified by the steering contractor as complying with the locating/tracking/steering equipment manufacturers recommended procedures.**

A log of directional drilling machine pressures during pulling operations converted to tensile stress seen in the pipe. Hydraulic pressure produced by the machine alone is not acceptable.

Experience and project resumes.

107.04        Experience

The directional drill contractor and locating/tracking/steering/contractor shall demonstrate experience in similar horizontal directional drills. Experience shall be a minimum of 5 successful installations of same or larger diameter of same or longer length in the previous 5 years. The directional drill contractor shall submit a list of references.

107.05        Placement and Testing

Perform all locates and pothole all potential conflicts prior to submitting the bore plan. The bore plan shall not be approved until all known conflicts have been resolved.

HDPE pipe shall be handled with care to include only the use of nylon slings for lifting and the use of appropriate sized pipeline rollers for supporting and maneuvering the pipe during fusion and pull back operations.

After fusing, prior to placement, the HDPE piping shall be filled with potable water and pressure tested at 100 psi for 2 hours. Each joint shall be visibly inspected for leakage at the end of 2 hours. Any sections showing visible leakage shall be cut out and the remaining pipe fused together and retested. After placement the HDPE pipe shall be pressure tested per Section 140.

All pipe installed below the water table shall be flooded with water prior to pulling operations.

Installations shall not exceed the pipe manufacturer's recommended radius of curvature.

The reamed hole shall not exceed 1.5 times the nominal diameter of the installed pipe.

All directional bores shall include one isolation valve on each end.

Upon completion bore pits shall be cleaned of excess drilling fluid and backfilled with clean fill.

**END OF SECTION 107**

## SECTION 109

### LARGE DIAMETER PVC PRESSURE PIPE

#### 109.01 General

It is the intent of this section to provide a uniform standard for all PVC pressure pipe used in force main construction, whose nominal diameter exceeds 12 inches.

#### 109.02 Larger Diameter PVC Pressure Pipe (D.I.O.D.)

All pipe shall meet the requirements for polyvinyl chloride pipe as specified in ASTM D2241, made from virgin PVC type 1120 compound with cell classification per ASTM D1784. The pipe shall be supplied in 20-foot lengths with an integral bell on each length and having a groove to retain the rubber sealing gasket. The other end of the pipe shall be cut square, beveled, and indelibly marked to the insertion depth. The pipe shall have a minimum dimension ratio (DR) of 25 with a pressure rating of not less than 150 psi. Outside diameter of the pipe shall be equal to ductile iron pipe. Pipe joints may be deflected up to the maximum deflection as recommended by the pipe manufacturer. Gaskets shall be as recommended by the pipe manufacturer for sewer application and shall comply with the requirements of ASTM F477.

The pipe manufacturer shall submit an affidavit of compliance that all materials used in the pipe production meet the requirements of Uni-Bell Pipe Association Standards and latest AWWA C-905 specifications.

PVC pressure pipe shall be installed with a magnetic tape suitable for locating pipe in the future. The tape shall be laid directly over the pipeline, at a depth (as recommended by the manufacturer) compatible with electronic pipe locators (not more than 18" deep from finished grade).

Electronic markers (EMS) shall be placed over the pipeline at each bend or valve along the length of the line (See Section 3.07).

#### 109.03 Fittings

Fittings shall be 40 mil epoxy lined ductile iron as specified in Sections 111 and 112.07.

#### 109.04 Installation

The pipe shall be installed in strict accordance with the manufacturer's recommendations. PVC pipe joints should not be deflected more than that recommended by the manufacturer's specifications.

No defective pipe or fittings shall be laid or placed in the piping, and any piece discovered to be defective after having been laid or placed shall be removed and replaced by a sound and satisfactory piece, at the Contractor's sole expense.

No PVC pipe shall be cut within a three (3) foot distance from the end of the bell end of the pipe.

Each pipe and fitting shall be cleared of all debris, dirt, etc., before being laid and shall be kept clean until accepted in the completed work.

Pipe and fittings shall be laid accurately to the lines and grades indicated on the Drawings. Care shall be taken to ensure a good alignment both horizontally and vertically.

Each length of pipe shall have a firm bearing along its entire length. Bedding as shown on the Standard Details shall be utilized. Compaction along the sides of pipe shall be strictly enforced at a minimum of 98% of AASHTD T-180 to a point one (1) foot above the pipe.

Pipe utilized for sewer force mains shall be colored green. Pipe used for reuse mains shall be colored purple throughout.

#### 109.05      Assembling Push-On-Joints

Push-on joints shall be made up by first inserting the gasket (where applicable) into the groove of the bell and applying a thin film of special nontoxic gasket lubricant uniformly over the spigot end of the pipe. The chamfered end of the plain pipe shall be inserted into the gasket and then forced past it until it seats against the bottom of the socket.

**END OF SECTION 109**



## SECTION 111

### DUCTILE IRON PIPE AND FITTINGS

#### 111.01 Pipe

All ductile iron pipe shall be designed in accordance with ANSI/AWWA C150/A21.50, 1976, or latest revision, based on a Type 2 bedding condition and shall be manufactured in accordance with ANSI/AWWA C151/A21.51. Along with the Record Drawings, the Design Engineer shall furnish the District a sworn statement from the manufacturer in accordance with Section 51.4.2 of ANSI/AWWA C151/A21.51, for truck load quantities of pipe. Each pipe shall be marked with the manufacturer's year of manufacture and the class of pipe. The words "Ductile Iron or D.I." shall be stamped on the pipe.

Ductile Iron Pipe shall be minimum Pressure Class 350 up to 20-inches in diameter and Pressure Class 250 for larger diameters.

Where ductile iron pipe is used, fittings shall be ductile iron and conform to the requirements of ANSI/AWWA C153/A21.53, and shall be of a pressure classification at least equal to that of the pipe with which they are used.

#### 111.02 Adapters

Where it is necessary to joint pipe of different type, the necessary adapters shall be utilized. Adapters shall have ends conforming to the above specifications for the appropriate type of joint to receive the adjoining pipe. Adapters joining two classes of pipe may be of the lighter class provided that the annular space in bell and spigot type joints will be sufficient for proper jointing.

#### 111.03 Types of Joints

Joints for ductile iron pipe shall be either push on or mechanical joint for buried piping and flanged joints for exposed or interior piping. Joints for pipe in casings shall be mechanical joint type with retainer glands unless otherwise approved by the District Engineer. Retainer glands shall be equal to those manufactured by EBBA Iron Corp., known as "meg-a-lugs".

Joint for mechanical joint pipe shall conform to ANSI/AWWA C111/A21.11. Joints for push on joint pipe shall be equal to "Tyton" as manufactured by United States Pipe and Foundry Company, or equal. If the pipe bell is grooved, the minimum thickness at the groove shall be equal to that of the thickness class specified herein.

The plain end of push on pipe shall be manufactured to a true circle and chamfered to facilitate fitting the gasket.

Push on and mechanical joint pipe and fittings shall be provided with sufficient quantities of accessories conforming to ANSI/AWWA C111/A21.11.

Flanges shall conform to ANSI B16.1, Class 125. All bolts and nuts for flanged pipe shall conform to ANSI B18.2.1. and B18.2.2 and manufactured of 316 S.S.

Gaskets shall be of a composition suitable for exposure to the liquid within the pipe.

#### 111.04 Lining and Coating

All ductile iron force main pipe and fittings shall be furnished with an interior epoxy lining. The lining material for pipe and fittings shall be epoxy coatings, 40 mil thick, and shall be "Protecto 401", "Permite 9043 Type II", or "Linerguard" and conform to the latest standards of ANSI/AWWA C104/A21.4.

The District will require that ductile iron pipes used in gravity sewers be lined with epoxy as specified above.

All buried pipe and fittings shall receive an external bituminous coating in accordance with ANSI 21.10.

All above ground ductile iron pipe and fittings shall receive a coated and painted green exterior (force mains) or purple (reclaimed water mains). The primer shall be TNEMEC-Aluminum Mastic #135 (3 to 5 mils DFT), the intermediate coat shall be Series 66 Epoxoline Hi-Build Epoxy (4 to 6 mils DFT) and the finish coat shall be Series 73 Endura-Shield III Urethane (2 to 3 mils DFT).

#### 111.05 Handling and Cutting Pipe

Every care shall be taken in handling and laying pipe and fittings to avoid damaging the pipe and linings, scratching or marring machined surfaces, and abrasion of the pipe coating or lining.

Any fitting showing a crack shall be marked as rejected and removed at once from the work.

In any pipe showing a distinct crack and in which it is believed there is no incipient fracture beyond the limits of the visible crack, the cracked portions, if so approved by the Design Engineer, may be cut off before the pipe is laid so that the pipe used is perfectly sound. The cut shall be made in the sound barrel at a point at least 12 inches from the visible limits of the crack.

Except as otherwise approved, all cutting shall be done with knives or saws adapted to the purpose. Hammer and chisel or so-called wheel snap cutters shall not be used to cut pipe. All cut ends shall be examined for possible cracks caused by cutting.

Cut ends to be used with push on joints shall be carefully chamfered to prevent cutting the gasket when the pipe is laid or installed.

Lined and coated pipe and fittings shall be installed as, and assembled as, recommended by the pipe manufacturer for the particular lining used.

#### 111.06 Installing Pipe and Fittings

No defective pipe or fittings shall be laid or placed in the piping, and any piece discovered to be defective after having been laid or placed shall be removed and replaced by a sound and satisfactory piece.

Each pipe and fitting shall be cleared of all debris, dirt, etc . before being laid and shall be kept clean until accepted in the complete work.

Pipe and fittings shall be laid accurately to the lines and grades indicated on the Drawings or required. Care shall be taken to ensure a good alignment both horizontally and vertically.

Electronic markers (EMS) shall be placed over the pipeline at each bend or valve along the length of the line and at intervals of not more than 300' on straight runs.

Each length of pipe shall have firm bedding along its entire length. Bedding requirements are shown on the Standard Details.

When mechanical joint, push on joint. or similar pipe is laid. the bell of the pipe shall be cleaned of excess tar or other obstruction and wiped out before the cleaned and prepared spigot of the next pipe is inserted into it. The new pipe shall be shoved firmly into place until properly seated and held securely until the joint has been completed. The ductile iron pipe shall not have a joint deflection greater than that recommended by the manufacturer.

#### 111.07 Temporary Plugs

At all times when pipe laying is not actually in progress, the open ends of pipe shall be closed by temporary watertight plugs. If water is in the trench when work is resumed, the plug shall not be removed until all danger of water entering the pipe has passed.

#### 111.08 Assembling Push On Joints

Push on joints shall be made up by first inserting the gasket into the groove of the bell and applying a thin film of special nontoxic gasket lubricant uniformly over the inner surface of the gasket which will be in contact with the spigot end of the pipe. The chamfered end of the plain pipe shall be inserted into the gasket and then forced past it until it seats against the bottom of the socket.

#### 111.09 Bolted Joints

Materials for bolted joints shall be as specified herein. Before the pieces are assembled, rust preventative coatings shall be removed from machined surfaces. Pipe ends, sockets, sleeves, housings, and gaskets shall be thoroughly cleaned and all burrs and other defects shall be carefully smoothed.

#### 111.10 Assembling Mechanical Joints

Surfaces against which the gasket will come in contact shall be thoroughly brushed with a wire brush prior to assembly of the joint. The gasket shall be cleaned. The gasket, bell, and spigot shall be lubricated by being washed in soapy water. The gland and gasket, in that order, shall be slipped over the spigot and the spigot shall be inserted into the bell until it is correctly seated. The gasket shall then be seated evenly in the bell at all points, centering the spigot, and the gland shall be pressed firmly against the gaskets. After all bolts have been inserted and the nuts have been made up finger tight, diametrically opposite nuts shall be progressively and uniformly tightened all around the joint to the proper tension, preferably by means of a torque wrench.

The correct range of torque shall not exceed the manufacturer's recommendation.

If effective sealing of the joint is not attained at the maximum torque indicated above, the joint shall be disassembled and thoroughly cleaned, then reassembled. Bolts shall not be over stressed to tighten a leaking joint.

#### 111.11 Restraints

Restrained joints shall be mechanical joint with ductile iron retainer glands, for pipe sizes 3 inches through 24 inches. The mechanical joints including the ductile iron retainer glands shall conform to ANSI/AWWA C111/A21.11 for Rubber Gasket Joints for Cast Iron and Ductile Iron Pressure Pipe and Fittings. All mechanical joint pipe and fittings shall be furnished with high strength cast iron tee head bolts and hex nuts with composition, dimensions, and threading in accordance with ANSI/AWWA C111/A21.11. The retainer glands shall be cast of high strength ductile iron and fitted with cup point, square head, double heat treated special alloy steel set screws. The retainer glands shall be EBBA Iron Corp. "Meg-a-Lug" or approved equal.

"Field Lok" push on retainer gaskets as manufactured by the U.S. Pipe and Foundry Co., or equal. can be used in lieu of retainer glands for ductile iron pipe sizes 4"-12". Restrained joints for ductile iron pipe and fittings greater than 12 inches may be of the single rubber compression gasket push on or mechanical joint type such as TR-FLEX as manufactured by U.S. Pipe and Foundry, Fastite Joint Pipe by the American Cast Iron Pipe Co., Locked Mechanical Joint F-217-D or Super-Lock Joint by the Clow Corporation, or approved equal.

When approved by the District, the Contractor may place reaction and thrust blocking at the back of tapping sleeves. Blocking shall be poured against firm compaction material. The concrete for thrust blocking shall be as specified under Concrete Masonry.

**END OF SECTION 111**

## SECTION 112

### POLYVINYL CHLORIDE GRAVITY SEWER PIPE

#### 112.01 General

This standard designates general requirements for un-plasticized polyvinyl chloride (PVC) plastic class pipe with integral bell and spigot joints for the conveyance of sewage. This class of pipe shall not be used where the depth of invert is greater than 14'-0" from finished grade, where there are special well field protection zones and for other scenarios where identified by the District's Engineer. In those cases, along with any other special cases required by the District Engineer, approved pressure pipe shall be utilized.

#### 112.02 Materials

Un-plasticized polyvinyl chloride pipe (PVC) shall be integral wall bell and spigot joints which meets the requirements of ASTM Specifications D3034 for SDR 26 or up to 15-inch diameter pipe. The pipe shall meet the following ASTM Standards: *D3212* (Joint), *F477* (Gasket) and *D1784* (PVC Compound).

Gravity sewer pipe and fittings from 18 inches through 27 inches shall meet ASTM F-879.

#### 112.03 Stiffness

The pipe stiffness for gravity sewer pipe shall have a minimum pipe stiffness of 115 psi when measured at 5% vertical deflection and tested in accordance with ASTM D2412.

#### 112.04 Pipe Bell

The bell of the pipe shall be designed to use a rubber ring gasket to allow for contraction and expansion. The bell shall consist of an integral wall section designed to be at least as strong as the pipe wall or an integral sleeve reinforced bell.

#### 112.05 Tests

##### 112.05.1 Acetone Test

A 2-inch long sample ring shall not flake or disintegrate when immersed for 20 minutes in a sealed container of acetone when conducted in accordance with ASTM *D2152*. (Swelling or softening is not considered a failure.)

##### 112.05.2 Flattening

A six inch long sample ring shall be compressed between parallel plates to 0.40% of the outside diameter of the pipe without evidence of splitting, cracking or breaking.

### 112.05.3 Impact Test

The pipe shall be tested at 73 degrees F and not fail an impact of a falling twelve (12) pound missile with a 2-inch radius at the levels prescribed by ASTM D2444. Sizes four inches through 12 inches shall pass an impact of 120 ft/lbs.

### 112.05.4 Marking

All PVC pipe shall be marked in accordance with Section 12.1 of ASTM D3034.

### 112.06 Standard Laying Lengths

All pipe shall be furnished in standard laying lengths provided by the pipe manufacturer.

### 112.07 Fittings

PVC sewer fittings shall conform to the requirements of ASTM D3034 specification with minimum wall thickness of SDR-26 as defined in section 7.4.1. Fittings in sizes through 8" shall be molded in one piece with elastomeric joints and minimum socket depths as specified in sections 6.2 and 7.3.2. Gaskets shall have a minimum cross-sectional area of 0.20 sq. in. and conform to ASTM F477 specification. Fittings in sizes not available in injection molded form shall be fabricated from SDR-26 thickness pipe and in accordance with section 7.11 of the specification with manufacturers standard pipe bells and gaskets.

### 112.08 Adapters

Where necessary to join pipe of different types, approved transition joints, as shown in the details, are acceptable. When joining sewer pipe to ductile iron or C-900 pipe, an adapter equal to Harco 300 series shall be used.

### 112.09 Handling and Cutting Pipe

The pipe manufacturer's recommendation for handling, storing, unloading and cutting pipe shall be followed. Individual pipes shall not be allowed to drop from the truck when unloading. Pipe units shall not be handled with chains or single cables. Pipe shall not be stored more than two units high. Every care shall be taken in handling and laying pipe and fittings to avoid damaging the pipe or scratching or marring machined or finished surfaces.

Any fitting showing a crack shall be marked as rejected and removed at once from the work.

In any pipe showing a distinct crack and in which it is believed there is not incipient fracture beyond the limits of the visible crack, the cracked portions, if so approved by the Design Engineer, may be cut off before the pipe is laid so that the pipe used is perfectly sound. The cut shall be made in the sound barrel at a point at least 12-inches from the visible limits of the crack.

Except as otherwise approved, all cutting shall be done with knives or saws adapted to the purpose. All cut ends shall be examined for possible cracks caused by cutting.

Cut ends to be used with push on joints shall be carefully chamfered and the reference mark located in accordance with the manufacturer's recommendation to prevent cutting the gasket when the pipe is laid or installed.

#### 112.10 Installing Pipe and Fittings

No defective pipe or fittings shall be laid or placed in the piping, and any piece discovered to be defective after having been laid or placed shall be removed and replaced by a sound and satisfactory piece.

Each pipe and fitting shall be cleared of all debris, dirt, etc., before being laid and shall be kept clean until accepted in the complete work. Pipe and fittings shall be laid accurately to the lines and grades indicated on the drawings or required. Care shall be taken to ensure a good alignment both horizontally and vertically.

Each length of pipe shall have a firm bearing along its entire length. Embedment requirements are shown on the Standard Details.

The bell of the pipe shall be cleaned of dirt or other obstruction and wiped out before the cleaned and prepared spigot of the next pipe is inserted into it. Only lubricants made by the pipe manufacturer may be used on the spigot. The new pipe shall be shoved firmly into place until properly seated and held securely until the joint has been completed.

#### 112.11 Temporary Plugs

At all times when pipe laying is not actually in progress, the open ends of pipe shall be closed by temporary watertight plugs. If water is in the trench when work is resumed, the plug shall not be removed until all danger of water entering the pipe has passed.

#### 112.12 Preparation of Trench Bottom

The trench bottom shall be constructed to provide a firm, stable and uniform support for the full length of the pipe. Unsuitable foundation material shall be removed as required by the Engineer and refilled with Class 1, 2, or 3 material. Class 2 or 3 material shall be compacted to a minimum of 90% standard proctor density.

#### 112.13 Backfill Materials for PVC Gravity Lines

Three broad classes of material shall be used for bedding, haunching, and pipe side support.

CLASS 1 - Angular, 1/4-inch to 3/4-inch graded stone,

of which 100% passes a 1-inch sieve such as coral, slag, cinders, crushed stone, crushed shells, or bedding rock.

CLASS 2 - Coarse sands and gravels with maximum particle size 3/4 inch including variously graded sands and gravels containing small percentages of fines, generally granular and non-cohesive, either wet or dry. Soil Types GW, GP, SW, and SP are included in this class.

CLASS 3 - Fine sand and clayey gravels, including fine sands, sand-clay mixtures, and gravel-clay mixtures. Soil Types GM, GC, SM, and SC are included in this class. Included in Class 3 are existing soil types classified as select backfill.

Class 1, Class 2, or Class 3 material shall be used for bedding material to the top of the pipe. Special care must be taken to insure Class 1, 2, or 3 material is worked under the pipe haunch. Class 2 or 3 material shall be compacted to a minimum of 98% density per AASHTO T -180. The District has the option, at any time, to take density tests to confirm the 98% compaction. Precautions shall be taken to prevent movement of the pipe when placing and compacting material under the pipe haunches.

If Class 2 or 3 material is used for bedding and haunching, a dry trench shall be maintained.

Under certain conditions, the Engineer may be faced with an unusual amount of water running in the trench which he may find necessary to remove in order to properly install and compact the embedment material. The Engineer may elect to remove the water with trench side pumps through the use of Class 1 material for bedding. The depth of Class 1 material will depend upon the amount of water but take care to ensure that the trench wall soil material is such that it will not be removed from the area adjacent to the bedding as a result of the running water. The Engineer may also elect to utilize well points or under drain to control excessive ground water. If Class 1 material is used as bedding and under drain, it must be utilized at least up to the top of the pipe.

#### 112.14 Manhole Connections

Where PVC gravity or force main pipe enters the manhole, approved sealing adapters as manufactured by Harco, Fernco or equal, shall be used. Any coupling used shall be coated with an epoxy coated sand finish approved by the District.

#### 112.15 Bell Holes for Elastomeric Seal Joints

When the pipe being installed is provided with elastomeric seal joints, bell holes shall be excavated in the bedding material to allow for unobstructed assembly of the joint. Care should be taken that



the bell hole is not larger than necessary to accomplish proper joint assembly. When the joint has been made, the bell hole should be carefully filled with bedding or haunching material to provide for adequate support of the pipe throughout the entire length.

112.16        Testing

Pipe deflection shall not exceed 5% measured by a go/no-go gauge or mandrel. The District may confirm the pipe deflection at the end of the job prior to acceptance. Additionally, the District may confirm the pipe deflection just prior to end of the one year guarantee period. Pipe sections exceeding 5% long term deflection will be relaid by the Contractor or the Developer at his own cost and expense and retested until the District's *go/no-go* gauge passes through the pipe section.

The District's mandrel will be considered the "official" gauge used for deflection testing. The standard District gauge is manufactured by "HURCO" Technologies, Inc., Harrisburg, S.D. The outside diameter of the District's mandrel is as follows:

Pipe Diameter (Inches)	Mandrel Diameter (Inches)
8	7.28
10	9.08
12	10.79

**END OF SECTION 112**

## SECTION 113

### 4"-12" DIAMETER POLYVINYL CHLORIDE FORCE MAIN PIPE

#### 113.01 General

This standard designates general requirements for un-plasticized Polyvinyl Chloride (PVC) plastic class pipe with integral bell and spigots joints for the conveyance of sewage: All pipe shall be marked as indicated in Section 2.5 of AWWA C-900, Latest Revision.

#### 113.02 Materials

All pipe shall meet the requirements of AWWA-C-900 "Polyvinyl Chloride (PVC) Pressure Pipe". The DR of the pipe shall be calculated based on Appendix A of AWWA C-900, using a Class C bedding. The minimum pipe stiffness is DR 18. The pipe shall be extruded in sizes 4-inches through 12 inches ductile iron pipe equivalent outside diameter. All Class 150 pipe shall be minimum DR-18.. The pipe shall meet the following ASTM Standards:

D1784 (PVC Compound), D3139 (Joint), and F477 (Gasket).

#### 113.03 Stiffness

The pipe stiffness using F/\Y PVC class pressure pipe is contained in the table below:

CLASS	DR	F/\Y
150	18	375
200	14	914

#### 113.04 Pipe Bell

The bell of the pipe shall be designed to use a rubber ring gasket to allow for contraction and expansion. The bell shall consist of an integral wall section designed to be at least as strong as the pipe wall or an integral sleeve reinforced bell. The gasket shall be secured in the race by means of a nonmetallic polypropylene retainer ring or snugly seated in deep grooves to protect gasket roll-out upon assembly.

#### 113.05 Tests

##### 113.05.1 Factory Test

Each joint of pipe shall pass a factory hydrostatic test at four (4) times the pressure class of the pipe for five seconds.

##### 113.05.2 Quick Burst Test

The pipe shall be designed to pass, without failure, the burst test for each rated class as follows:

DR 18 (755 psi) and  
DR 14 (985 psi)

113.05.3      Acetone Test

A 2-inch long sample ring shall not flake or disintegrate when immersed for 20 minutes in a sealed container of acetone when conducted in accordance with ASTM 0-2152. (Swelling or softening is not considered a failure).

113.05.4      Flattening

A 2-inch long sample ring shall be compressed between parallel plates to 40% of the outside diameter of the pipe without evidence of splitting, cracking, or breaking.

113.05.5      Impact Test

The pipe shall be tested at 73 degrees F and not fail an impact of a falling twelve (12) pound missile with a 2-inch radius at the levels prescribed by ASTM D2444. Sizes 4-inches through 12-inches shall pass an impact of 120 ft./lbs.

113.06          Fittings

Fittings shall be ductile iron conforming to AWWA Standard C-153 or approved PVC fittings, conforming to AWWA Standard C-907.

113.07          Adapters

Where it is necessary to joint pipe of different type, the necessary adapters shall be utilized. In the case of gravity sewers and service connections, transition joints as shown on the Details are acceptable. Adapters shall have ends conforming to the above specifications for the appropriate type of joint to receive the adjoining pipe. Adapters joining two classes of pipe may be of the lighter class provided that the annular space in bell and spigot type joints will be sufficient for proper jointing.

113.08          Handling and Cutting Pipe

The pipe manufacturer's recommendation for handling, storing, 'Unloading, and cutting pipe shall be followed. Individual pipes shall not be allowed to drop from the truck when unloading. Pipe units shall not be handled with chains or single cables. Pipe shall not be stored more than two units high. Every care shall be taken in handling and laying pipe and fittings to avoid damaging the pipe or scratching or marring machined or finished surfaces.

Any fitting showing a crack shall be marked as rejected and removed at once from the work.

In any pipe showing a distinct crack and in which it is believed there is not incipient fracture beyond the limits of the visible crack, the cracked portions, IT so approved by the Design Engineer, may be cut off before the pipe is laid so that the pipe used is perfectly sound. The cut shall be made in the sound barrel at a point at least 12-inches from the visible limits of the crack.

Except as otherwise approved, all cutting shall be done with knives or saws adapted to the purpose. All cut ends shall be examined for possible cracks caused by cutting.

Cut ends to be used with push-on joints shall be carefully chamfered and the reference mark located in accordance with the manufacturer's recommendation to prevent cutting the gasket when the pipe is laid or installed.

#### 113.09        Installing Pipe and Fittings

No defective pipe or fittings shall be laid or placed in the piping, and any piece discovered to be defective after having been laid or placed shall be removed and replaced by a sound and satisfactory piece.

Each pipe and fitting shall be cleared of all debris, dirt, etc., before being laid and shall be kept clean until accepted in the complete work. Pipe and fittings shall be laid accurately to the lines and grades indicated on the Drawings or required. Care shall be taken to ensure a good alignment both horizontally and vertically.

Each length of pipe shall have a firm bearing along its entire length. Embedment requirements are shown on the Standard Details.

The bell of the pipe shall be cleaned of dirt or other obstruction and wiped out before the cleaned and prepared spigot of the next pipe is inserted into it. Only lubricants made by the pipe manufacturer may be used on the spigot. The new pipe shall be shoved firmly into place until properly seated and held securely until the joint has been completed. The ductile iron pipe shall not have a joint deflection greater than that recommended by the manufacturer:

#### 113.10        Temporary Plugs

At all times when pipe laying is not actually in progress, the open ends of pipe shall be closed by temporary watertight plugs. If water is in the trench when work is resumed, the plug shall not be removed until all danger of water entering the pipe has passed.

#### 113.11        Restraint

Approved retainer glands equal to "Meg-a-Lug" as Manufactured by Ebba Iron Manufacturing Company made specifically for restraining PVC (C-900) force mains will be used.

**END OF SECTION 113**

## SECTION 114

### 4"-65" DIAMETER HIGH DENSITY POLYETHYLENE FORCE MAIN PIPE

#### 114.01 General

This standard designates general requirements for high density polyethylene pipe used in force main installations. All piping shall be marked as indicated in AWWA C-906, latest revision with the following minimum information; AWWA C-906, diameter, dimension ratio, resin and pressure rating.

#### 114.02 Materials

All pipe shall be manufactured from PE4710, be minimum DR-11, 200 psi, meet the requirements of AWWA-C-906 and be listed with the Plastic Pipe Institute's (PPI) TR4. The resin shall be formulated with carbon black and/or utilize ultraviolet stabilizer for protection against UV rays. The pipe shall meet the following ASTM Standards D3350 and F714.

Single joints of pipe shall be a minimum of 40 feet in length. Damaged pipe may have the damaged area cut out and the remaining portion reused as long as the remaining portion is a minimum of 20 feet in length.

#### 114.03 Fittings and Adapters and Restraints

Molded butt fusion fittings and adapters shall conform to ASTM D 3261, utilize HDPE conforming to this specification and have the same dimension ratio as the pipe. All fittings shall be pressure rated to provide a working pressure rating no less than that of the pipe.

Pipe stiffeners shall be used in conjunction with ductile iron fittings where MJ or flanged adapters are not used. The pipe stiffeners shall be 316 stainless steel as manufactured by JCM Industries or pre-approved equal. Pipe stiffeners in conjunction with ductile iron fittings shall only be used with the written approval of the District Engineer for HDPE pipe 12" diameter and smaller. When approved, MEGALUG Series 2000PV mechanical joint restraints or approved equal shall be used.

#### 114.04 Handling and Cutting Pipe

The pipe manufacturer's recommendation for handling, storing, Unloading, and cutting pipe shall be followed. Individual pipes shall not be allowed to drop from the truck when unloading. Pipe units shall not be handled with chains or single cables. Pipe shall not be stored more than two units high. Every care shall be taken in handling and laying pipe and fittings to avoid damaging the pipe or scratching or marring machined or finished surfaces.

Any fitting showing slices, scratches or gouges shall be rejected and removed at once from the work.

Any pipe showing slices, scratches or gouges where it is believed there is not damage beyond the limits of the visible defect, if so approved by the Design Engineer, may be cut off at a point at least 12-inches from the visible limits of the crack so long as the resulting piece does not violate the minimum length allowed.

Except as otherwise approved, all cutting shall be done with knives or saws adapted to the purpose. All cut ends shall be examined for possible cracks caused by cutting. All cuts shall be square and smooth.

#### 114.05      Butt Fusion Joining

All HDPE pipe and fittings shall be butt fused following the procedures outlined in ASTM F2620 Standard Practice for Heat Fusion Joining of Polyethylene Pipe and Fittings. Fusion machine operators shall hold current certifications for fusing HDPE meeting ASTM F2620.

#### 114.06      Installing Pipe and Fittings

See Section 107 Horizontal Directional Drill.

#### 114.07      Temporary Plugs

The open ends of pipe shall be closed by temporary watertight plugs at all times. If water is in the trench when work is resumed, the plug shall not be removed until all danger of water entering the pipe has passed.

**END OF SECTION 114**

**SECTION 120**  
**CONCRETE MASONRY**

120.01      Materials

120.01.1    Concrete

Ready-mixed concrete shall be used. It shall comply with the Standard Specifications for Ready-Mixed Concrete, ASTM Designation C94 for the strengths specified herein. Alternate No.2, under Paragraph 4 - Quality of Concrete ASTM C94 shall govern for the design of the concrete mixture.

120.01.2    Cement

Type I cement shall be used in concrete for general purposes. Type II cement shall be used for sewer manholes, wet wells, and all other applications where the concrete may be exposed to a wastewater atmosphere.

120.01.3    Reinforcing Steel

Reinforcing bars and mesh shall be sizes and shapes as indicated on the drawings. Bars shall be deformed bars of intermediate grade, new billet steel conforming with ASTM Designation A-615, Grade 60. Wire mesh shall conform with ASTM Designation A-185.

120.01.4    Water Stops

Water stops shall be molded PVC, hollow center bulb, multiple ribbed as manufactured by W.R. Meadows, Inc., Electrovert, Inc. or Serviced Products Corporation, or approved equal.

120.02      Concrete

120.02.1    Mix

Concrete shall be composed of Portland cement, coarse aggregate, fine aggregate and water. The concrete mix shall be designed to produce the quality specified, proportioned and mixed in accordance with the requirements set forth herein and shall in all cases meet the following requirements:

<u>Class</u>	<u>Location</u>	<u>28 Day Compressive Strength</u>
A.	Specifically Required on Plans	4,000 psi
B.	General Structural Concrete	3,000 psi



C. Non-structural Applications 2,500 psi

120.02.2 Slump

The concrete, when placed, shall show slumps within the following limits when tested in accordance with the Method of Test for Slump of Portland Cement Concrete, ASTM Standard Specification C-143.

<u>Type of Concrete</u>	<u>Min. Slump</u>	<u>Max. Slump</u>
Mass Concrete	1 Inch	3 Inches
Reinforced Concrete:		
Thin vertical sections and thin columns, 7 inches or less in thickness	3 Inches	6 Inches
Heavy vertical sections more than 7 inches in thickness	3 Inches	5 Inches
Structural Slabs	1 Inch	4 Inches

120.02.3 Air Entraining

Air entrained concrete shall conform with the following requirements:

	<u>Maximum Aggregate Size(Inches):</u>				
	<u>3/8:</u>	<u>1-2:</u>	<u>3/4:</u>	<u>1:</u>	<u>1-1/2:</u>
Average total air content, percent (Plus or minus 1%):	5	5	4	4	3

120.03 Placing Concrete

Concrete shall be placed before the initial set has occurred and in no event after it has contained its water for more than 30 minutes.

The concrete shall be compacted and worked in an approved manner into all corners and angles of the forms and around reinforcement and embedded fixtures in such a manner to prevent segregation of the coarse aggregate.

All concrete shall be placed with an aid of mechanical vibrating equipment supplemented by hand forking or spading. Vibration shall be transmitted directly to the concrete and not through the forms. The duration of vibration at any location in the forms shall be held to a minimum necessary

to produce thorough compaction. The concrete shall be placed by suitable equipment as nearly as possible to its final location and without any segregation of the aggregate. Any free vertical drop shall not exceed 4-1/2 feet.

Expansion joints shall be placed as indicated on the plans. Joint material shall be installed as indicated and as approved by the Design Engineer. Construction joints shall be made only at locations indicated on the plans or approved by the Design Engineer, and in such manner as not to impair the strength, water-tightness or appearance of the structure.

#### 120.04        Finishing

All top surfaces which are not covered by forms and which are not to be covered by additional concrete or backfill, shall be carried slightly above grade and struck off by board finish. All edges shall be provided with a 3/4 inch chamfer. All exposed surfaces which show board marks, joint marks or other irregularities after the forms are removed shall, at the discretion of the Design Engineer, be rubbed with carborundum brick, filled or otherwise dressed to produce a smooth true surface.

No special concrete or cement mortar topping course shall be used for slab finish unless shown on the drawings. The slab shall be brought to a true and even finish by power or hand floating. Unless otherwise specified, the surface shall be steel troweled to a smooth finish. Troweling shall be the minimum to obtain a smooth, dense surface and shall not be done until the mortar has hardened sufficiently to prevent excess fine material from being worked to the surface. The top surface of the wet well shall immediately after troweling, be brushed lightly with a soft bristle janitor's push broom to produce a non-slip surface. The brushing shall be sufficient to mark the surface only without appreciably disturbing the troweled finish.

#### 120.05        Curing

All concrete shall be kept wet by covering with water and approved water saturated covering, or other approved method which will keep all surfaces continuously wet for a period of seven (7) days, unless otherwise specified by the Design Engineer. All concrete shall be adequately protected from injurious action by the sun. Fresh concrete shall be protected from heavy rains, flowing water and mechanical injury. All concrete shall be kept damp for at least seven (7) days by covering with an approved saturated covering, by a system of perforated pipes or mechanical sprinklers, or by any other approved method which will keep all surfaces continuously damp.

Where wood forms are left in place during curing, they shall be kept wet at all times to prevent opening at the joints and drying out of the concrete. Water for curing shall be clean and entirely free from any elements which might cause staining or discoloration of the concrete.

120.06        Forms

Forms shall be of wood, metal, or other approved material shall be built true to line and grade, mortar tight, adequately braced and supported, and sufficiently rigid to prevent displacement or sagging.

Forms, except those lined with absorptive form lining, shall be coated with a non-staining mineral oil applied shortly before placing the concrete. In lieu of oiling, forms for unexposed surfaces may be thoroughly wetted immediately before placing the concrete.

Forms ties shall be of a design such that when forms are removed no metal shall be within 1 inch of the finished surface. Holes remaining from withdrawn tie rods or bolts shall be filled solid with cement mortar.

Under normal conditions, the minimum waiting period after placing concrete for stripping forms shall be as follows:

<u>Where Used</u>	<u>Time</u>
1. Bottom forms of girders and beams, floor slabs, and other concrete.	5 Days
2. Walls, piers, columns, sides of beams, and other vertical surfaces.	24-48 hours

The use of this schedule shall not operate to relieve the Contractor or the Design Engineer of responsibility for the safety of the structure.

120.07        Embedded Items

In addition to steel reinforcement, pipes, and other metal objects, as shown on the plans or ordered to be built into, or set in, or attached to the concrete, all necessary precautions shall be taken to prevent these objects being displaced, broken, or deformed. Before concrete is placed, care shall be taken to determine that any embedded or wood parts are firmly and securely fastened in place as indicated. They shall be thoroughly cleaned and free of paint or other coating, rust, scale, oil, or any foreign matter. The embedding of wood in concrete shall be avoided whenever possible; metal being used instead. The concrete shall be packed tightly around the pipes and other metal work to prevent leakage and to secure perfect adhesion. Drains shall be adequately protected from intrusion of concrete.

Concrete placing operations shall not begin until the reinforcing steel, utilities, anchor bolts, etc., to be embedded in concrete have been inspected and approved by the Design Engineer.

120.08      Laboratory Services

Laboratory Services shall be performed by an independent commercial testing laboratory approved by the District. The Design Engineer shall furnish the District with copies of compression and slump test reports for every thirty (30) cubic yards or portion thereof of concrete placed. It shall be the responsibility of the Design Engineer to produce concrete of the strength, durability, workability and finish specified, furnish representative material for specimens in quantities required by the testing laboratory, and cooperate and assist in taking samples of materials for testing. The District reserves the right to take and test additional concrete samples.

**END OF SECTION 120**

## SECTION 121

### MANHOLES AND STRUCTURES

#### 121.01 General

Manholes and structures shall conform in shape, size, dimensions, materials and other respects to the Standard Details or as directed by the District's Engineer.

All manholes shall be precast concrete with monolithic base sections. Invert channels may be formed in the concrete of the base or may be formed of brick and mortar upon the base.

All manholes which will receive direct force main discharges, or are at least 14-feet deep (rim to lowest invert) and the last collection manhole just upstream of any lift station shall receive a minimum 0.5-inch thick calcium aluminate corrosion barrier such as Sewper Coat, Strong Seal, Refratta HAC 100 or approved equal, and installed per the manufacturers recommendations.

The inverts shall conform accurately to the size of the adjoining pipes. Sides inverts shall be curved and main inverts (where direction changes) shall be laid out in smooth curves of the longest possible radius which is tangent to the centerlines of adjoining sewers.

Connections to existing structures shall be made only by mechanically coring a hole through the structure. Jackhammer and other methods of cutting a hole through an existing structure are not acceptable.

Rubber "boots" subject to District approval, will be allowed for making pipe connections to structures provided that a layer of non-shrink grout be applied to seal the annular space on the inside of the manhole for the full wall thickness. The boots shall be cast in the precast structure and shall utilize stainless steel bands and screws.

The frames and covers shall be set to conform accurately to the grade of the finished pavement or roadway surface; in unsurfaced areas, the frames and covers shall be set 3-inches higher than the surrounding ground surface.

Concrete shall conform to the requirements specified under Concrete Masonry.

#### 121.02 Precast Concrete Sections

Precast concrete sections, if used, shall conform to the ASTM Specifications for Precast Reinforced Concrete Manhole Risers and Tops, Designation C-478 - Latest Revision, with the following exceptions and additional requirements:

Type II cement shall be used.

Sections shall be steam cured and shall not be

shipped until at least five (5) days after having cast.

Acceptance of the sections will be on the basis of material tests, finished quality, and inspection of the completed product.

Cones shall be 30" - concentric type

Joint material in riser sections shall be of the bitumastic type as manufactured by RAM-NEK or equal.

No more than two (2) lift holes may be cast or drilled in each section.

#### 121.03      Shallow Manhole

When the depth from the deepest invert to the top of the cone section is 4'-0" or less, an approved shallow cone section with a 30" opening shall be used. In no case shall a flat slab top section be used.

#### 121.04      Setting Precast Sections

Precast reinforced concrete sections shall be set so as to be vertical with sections in true alignment.

All holes in sections, used for their handling, shall be thoroughly plugged with mortar. The mortar shall be one part cement and 1-1/2 parts sand; mixed slightly damp to the touch (just short of "balling"); hammered into the holes until it is dense and an excess of paste appears on the surface; and then finished smooth and flush with the adjoining surfaces.

Anti-hydro grout shall be used to fill all voids around sanitary sewer pipe and manhole sections.

#### 121.05      Mortar for Brick and Concrete Block Work

The mortar shall be composed of Portland cement, hydrated lime, and sand, in which the volume of sand shall not exceed three (3) times the sum of the volumes of cement and lime. The proportions of cement and lime shall be as directed and may vary from 1:1/4 for dense, hard burned brick to 1:3/4 for softer brick. In general, mortar for Grade SA brick shall be mixed in the proportions of 1:1/2:4-1/2.

Cement shall be Type II Portland cement as specified for under Concrete Masonry.

Hydrated lime shall be Type "S" conforming to the ASTM Standard Specification for Hydrated Lime for Masonry Purposes, Designation C207 - Latest Revision.

The sand shall be well graded clean, durable particles all of which shall pass a No. 8 sieve.

121.06        Laying Brick

Only clean, red, fire cured brick shall be used. The brick or block shall be moistened by suitable means, as directed, until they are neither so dry as to absorb water from the mortar, nor so wet as to be slippery when laid.

Each brick or block shall be laid in a full bed and joint of mortar without repairing subsequent grouting, flushing, or filling, and shall be thoroughly bonded as directed.

121.07        Plastering and Curing Brick

Outside faces of brick shall be plastered with mortar from 1/4 inch to 3/8 inch thick. If required, the brick shall be properly moistened prior to application of the mortar. The plaster shall be carefully spread and troweled so that all cracks are thoroughly worked out. After hardening, the plaster shall be carefully checked by being tapped for bond and soundness. Unbonded or unsound plaster shall be removed and replaced.

Brick and plaster shall be protected from too rapid drying by the use of burlaps kept moist, or by other approved means and shall be protected from the weather, all as required.

121.08        Frames and Covers

The castings for the frames and covers shall be of good quality, strong, tough, even grained cast iron, smooth, free from scale, lumps, blisters, sandholes and defects of every nature which render them unfit for the service for which they are intended.

All castings shall be thoroughly cleaned and subject to a careful hammer inspection.

Casting shall be at least Class 30 conforming to the ASTM Standard Specification for Gray Iron Castings, Designation A48- Latest Revision, and conform to the standard details.

The contact surface of the frame and cover seat shall be a machine fit and the cover surface shall be "knobbed".

Before being shipped from the foundry, castings shall be given one coat of coat tar pitch varnish, applied in a satisfactory manner so as to make a uniform coating which does not tend to scale off.

121.09        Setting Frames and Covers

Frames shall be set with the tops conforming accurately to the grade of the pavement or finished roadway surface, in unsurfaced areas the frames and covers shall be set 3 inches higher than the surrounding ground. Frames shall be set concentric with the top of the masonry and in a full bed of mortar so that the space between the top of the manhole masonry and the bottom flange of the

frame shall be completely filled and made watertight. A thick ring of mortar extending to the outer edge of the masonry shall be placed around the bottom flange. The mortar shall be smoothly finished to be flush with the top of the flange and have a slight slope to shed water away from the frame.

Cover shall be left in place in the frames on completion of other work at the manholes.

121.10            Adjustment of Existing Manhole Frames

When it is necessary to raise existing manhole frames due to repaving of roads or other reasons, the frames shall be shimmed with masonry, brick and Type II cement mortar to the new finished grade, or in the case of sodded areas, 2" above finished grade. In no case shall adjustment rings or adapters be used, unless specifically authorized by the District.

When new paving operations cause the manhole frame to be adjusted upwards, manholes will be raised using conventional shimming methods under the frame. The use of adapter rings in the existing frame will not be permitted.

**END OF SECTION 121**



## SECTION 122

### GREASE INTERCEPTORS AND TRAPS

#### 122.01 Grease, Oil and Sand Interceptors

##### 122.01.1 Grease Interceptors

Grease, oil and sand can be a serious problem for any sewer system if not taken care of properly and adequately. When grease is discharged into a gravity collection system, it can cause operation and maintenance problems not only inside those gravity lines, but also with the downstream lift stations and force mains. Additionally, grease inhibits the biological processes at the wastewater treatment plant.

Frequent and adequate cleaning of interceptors is important and often over looked. Interceptors shall be provided when the resultant discharge from a business contains excessive amounts of grease, oil, lint, sand or other solids and substances that are harmful or hazardous when discharged into wastewater, or in the opinion of the District Engineer the resultant discharge from such occupancy will be detrimental to the District facilities.

Grease interceptors will be required on all food service establishments where any kind of food is prepared on site, or in the opinion of the District Engineer the resultant discharge from such occupancy will be detrimental to the District facilities. Examples of businesses that will be required to have a grease interceptor are restaurants, delis, bakeries, sandwich shops, schools, hospitals, assisted and independent living facilities, etc.

Grease interceptors will be sized according to one of the two (2) formulas listed in the 2010 Florida Building Code - Plumbing, Chapter 10 – Traps, Interceptors and Separators, Table 1003.5.1, whichever best applies for the proposed establishment. The minimum sized grease interceptor shall be 750 gallons, which will also apply to businesses where the above formulas might not directly apply.

When multiple tanks are required, they must be installed in series. This also applies to pre-existing restaurants (or other facilities) that require additional capacity to augment their existing interceptors.

Interceptors shall not be shared. Each business location is required to have its own interceptor(s) and its own separate plumbing to the interceptor(s). When the same establishment has multiple discharge points that require installation of interceptors at different locations, such as an institutional facility with a kitchen and a laundry, each use shall be provided with separate plumbing and the required interceptor(s).

All equipment and plumbing fixtures in a food service facility that may introduce fats, oil or grease into the LRD wastewater facilities must be connected through the grease

interceptor, including but not limited to:

- a. Scullery sinks (two or three compartment)
- b. Pots and pan sinks
- c. Floor drains in kitchen, walk-in coolers and washing areas (not including public restrooms)
- d. Pre-wash sinks
- e. Dishwashers and other washing machines
- f. Automatic hood wash units
- g. Indoor garbage can washes

Under the counter (flow-based) grease traps are not allowed.

#### 122.01.2 Oil/Sand Interceptors

Oil/Sand interceptors are required for all car washes and establishments with facilities for servicing vehicles/mechanical equipment. All plumbing (other than the restroom) from the area where repairs and maintenance is being performed shall connect to an oil/sand interceptor; this includes but is not limited to floor drains and hand wash sinks. Engine oil, transmission oil, coolant, solvents, additives, brake fluid or any other fluid collected in the process of servicing vehicles/mechanical equipment shall not be discharged into the interceptor or other plumbing; the handling and disposal of these fluids shall be in compliance with the DEP and LRD rules and regulations.

Oil/Sand interceptors are also required for hydraulic and all outdoor elevators, such as in parking garages, where sump pumps and/or drains are proposed to discharge to LRD's sewer system. Oil/sand interceptors are not required for indoor elevators with an approved alarm system that meets the 2010 Florida Building Code.

Oil/Sand separators shall be sized based upon the 2010 Florida Building Code - Plumbing, Chapter 10 – Traps, Interceptors and Separators, Section 1003.4.2.2. The minimum sized oil/sand separator shall be 750 gallons.

#### 122.02 Lint Interceptors

Lint interceptors are required for all laundromats and all establishments with a central laundry room with at least 5 washing machines or more. Interceptors shall be equipped with a wire basket or similar device that's removable for cleaning and prevents passage of solids ½" or larger in size, strings, rags, buttons or other materials detrimental to the

wastewater facilities. Lint interceptors shall be sized based on the following formula: Number of washers X 2 cycles per hour X 20 gallons per cycle flow rate X 2.0 hours retention time X 1.5 storage factor. The minimum sized lint interceptor shall be 750 gallons.

#### 122.03 General Requirements

All interceptor construction shall be concrete and shall meet all applicable standards in Chapter 64E-6, Florida Administrative Code.

All interceptors shall be provided with two (2) access manholes: one (1) over the inlet and one (1) over the outlet. LRD approved, traffic rated lids shall be installed with manhole covers to finished grade. Manhole frame & covers and inside openings in the top slab, for tanks sized 1,250 gallons or less, shall be manufactured by US foundry with a 24-inch minimum clear opening. Manhole frame & covers and inside openings in the top slab, for tanks larger than 1250 gallons, shall be US foundry, model 230-AB-M, double ring & cover, with a 30-inch minimum clear opening.

All manhole covers shall be marked with the lettering: “GREASE”, “OIL” or “LINT”, as applicable.

Wastewater from toilets, urinals, showers, and other similar plumbing fixtures for human waste shall not discharge into an interceptor.

#### 122.04 Grease Interceptor Exemptions

There are instances where a food service establishment may not require a grease interceptor. In these instances an exemption from a grease interceptor may be allowed. In order to qualify for an exemption, the following minimum criteria must be met.

- No food preparation on-site.
- The following equipment is prohibited from being on-site: oven, dishwasher, stove top cooking surfaces/griddle, fryers, ranges, or any equipment used to cook food.
  - Only pre-made food may be allowed to be heated on-site using the following equipment: toasters, microwaves or sandwich presses.
- If serving food on-site, all food is served on paper/plastic plates using disposable utensils or in the pre-packaging it was brought on-site in.
- All condiments are pre-packaged in individual servings.

If the above criteria cannot be initially met or if it is found that after an exemption is given the above criteria are no longer being met, then a District-approved grease interceptor must be installed. Failure to do so will result in a violation of the District’s Sewer Use Rule outlined in Chapter 31-13, Florida Administrative Code, which may result in fines against the property.

Any exemptions provided are permanent, so long as these requirements are met.

**END OF SECTION 122**

## SECTION 130

### VALVES AND APPURTENANCES

#### 130.01 General

All buried valves and appurtenances including exposed nuts, bolts, and retainer glands shall be given an exterior approved bitumastic or epoxy coating. All valves shall open counterclockwise. All valves shall have extension stems pinned to the operating nut with a stainless steel pin extension. Stems will not be required where the valve operation nut is less than 30" from finished grade.

Contractors must supply LRD with shop drawings clearly indicating that the criterion for each type of valve or appurtenance listed in this section is satisfied.

#### 130.02 Plug Valves

All mechanical joint and flanged plug valves shall be of the nonlubricated eccentric type. Valves shall be rated for not less than 125 psi pressure differential acting in either direction (bi-directional). At this differential, the valve shall provide drip tight shutoff. All components shall be of corrosion resistant construction. Valve flanges shall be ANSI B16.1, class 125 pound with a full round or other acceptable type port to assure minimum turbulence and minimum pressure drop. Valve bodies shall be of ductile iron and seats shall be of nickel-alloy. Valves are to have a balance plug, coated with a resilient material solidly bonded to a cast iron or semi-steel core, as required, to assure low torque and bubble-tight shutoff. The valve plug shall touch on the seat when in the closed position.

Plug valve port areas shall be at least 100% through 24 inches in diameter. For plug valves 30" and larger, a port area of at least 75% is required.

Buried plug valves shall be installed vertically with non-rising stems and shall open by turning a two inch square operating nut counterclockwise. An arrow shall be cast into the nut skirt to indicate the open direction.

Plug valves shall be as manufactured by DeZurik Corporation, Milliken, Keystone Valve Manufacturing Company (Ballcentric Type), or approved equal.

#### 130.03 Resilient Seat Gate Valves

Gate valves shall be resilient seated, manufactured to meet or exceed the requirements of AWWA C509 or C515, Latest Revision, and in accordance with the following specifications. Valves shall have an unobstructed waterway canal equal to or greater than the full nominal diameter of the valve.

The valves are to be non-rising stem with the stem made of cast, forged, or rolled bronze as shown in AWWA C509. Two stem seals shall be provided and shall be of the O-ring type, one above and one below the thrust collar. A 2-inch square operating nut shall be provided for operating the valve. The stem nut, also made of bronze, may be independent of the gate or cast integrally with the gate. If the stem nut is cast integrally, the threads shall be straight and true with the axis of the stem to avoid binding during the opening or closing cycle.

The valve body, bonnet, and bonnet cover shall be ductile iron. All ferrous surfaces inside the valve body shall have a fusion bonded epoxy coating applied at the valve manufacturer's facilities. The coating shall meet or exceed all requirements of AWWA C550. All bolts, nuts and washers shall be stainless steel to limit exterior corrosion and maintain fastener strength.

The sealing mechanism shall consist of a cast iron or ductile iron gate having a vulcanized Buna-N or SBR synthetic rubber coating or a Buna-N rubber seat mechanically retained on the gate. The resilient sealing mechanism shall provide zero leakage at 250-psi working pressure. All valves shall have pressure tests performed to the requirements of AWWA C509 or C515 specifications, as applicable, prior to shipment from the manufacturer. Valve shall seat and be drip-tight at the working pressure when installed with the line flow in either direction.

All valves are to be tested in strict accordance with AWWA C509. Resilient seat gate valves shall be as manufactured by Mueller, Metro-Series, American Darling or approved equal.

Valves shall be covered by a Manufacturer's 10 year limited warranty from date of purchase by end user and delivered within 30 days from receipt of purchase order. The supplier will also provide laminated maintenance manuals.

#### 130.04        Swing Check Valves

Swing check valves for sewage, sludge, and general service shall be in accordance with AWWA C 508, unless otherwise specified below, full-opening; designed for a working pressure of 150 psi unless otherwise shown, and shall have a flanged cover piece to provide access to the disc. Corrosive ferrous surface of valves, 4-inch and larger, which will be in contact with water, shall receive a fusion-bonded epoxy coating conforming to AWWA C550. The valve body and cover shall be of cast iron to ASTM A126, with flanged ends to ANSI B16.1, or mechanical joint ends, as shown.

The valve disc shall be of cast iron, ductile iron, or bronze to ASTM B 62. The valve seat and rings shall be of bronze to ASTM B 92 or B 148, or stainless steel. The hinge pin shall be of bronze or stainless steel.

Suppliers or Equal:

American-Darling Valve Co.

APCO (Valve and Primer Corp.)

Crane Company

Mueller Co.

The valves shall have a lever and counterweight and shall be suitable for horizontal or vertical mounting.

#### 130.05 Air Release, Air Vacuum Valves, and Combination Type Valves

The air release and air vacuum valves shall be of the type especially designed for forced sewer systems. The valve shall be of the short body type and capable of releasing air, gas, or vapor under pressure during system operation or allow air to enter the system when the system is draining, as applicable. The valve shall be as shown on the Standard Details with a two inch inlet. The venting orifice shall be sized by the Design Engineer based on a working pressure of 75 psi.

It shall be the responsibility of the design engineer to determine which valve is necessary for the pipeline conditions encountered.

Air release and air vacuum valves shall be ARI D-025 (See Standard Details).

#### 130.06 Ball Valves

Ball valves shall be limited to 3/4" through 2-1/2" in size and shall have cast brass, bronze or stainless steel body, bronze tee head, stem with check, full round way opening and provision for locking in a closed position.

Ball valves can be used for force main and low pressure sewer applications up to 2-1/2" in diameter. The primary use in force main applications is for ARV isolation valve use (See Standard Details).

Valves shall be designed to be fully opened with a 90-degree turn of the operating handle and shall be full port design with bi-directional sealing rated for a minimum 150 psi working pressure.

Brass ball valves in the low pressure system valve shall be as manufactured by Ford , or approved equal, with NPT or pack joint ends as needed.

Where these valves are direct buried, a 2" square gate valve operating nut shall be included.

#### 130.07 Brass Check Valves

Brass check valves shall be Proflo PFX31 size 1-1/2" to 2".

130.08        Valve Boxes and Vaults

All buried valves shall be equipped with a valve box. Valve boxes shall be heavy duty construction for traffic loading type, cast iron, three piece, slide type, or screw type with drop covers. The valve boxes shall be adjustable to six inches up or down from the nominal required cover of the pipe.

A number six base section shall be provided. Minimum shaft diameter shall be 5-1/4 inches and minimum metal thickness shall be 3/16 inch. Boxes shall be coated with an approved bitumastic or epoxy coating. Valve box covers shall have the word "SEWER" or "REUSE" cast thereon depending on the application. Swing check valves shall be installed in an approved suitable vault for easy access by the District maintenance staff.

Valve boxes shall be installed on firmly compacted material at a level approximately equal to the elevation of the valve packing plate. No contact between the valve and the box shall be permitted. On plug valves, the positioner on the operating mechanism shall be kept free of rocks, debris, etc.

Where valves are installed with over six feet of cover, or where the ground water table is within three feet of the ground level, an extension stem shall be provided to bring an operating nut within two feet of the finished grade. This extension, stem shall be satisfactorily pinned to the valve operation nut to prevent dislodging during operation of the valve.

**END OF SECTION 130**



## SECTION 140

### PIPELINE INTEGRITY TESTS

#### 140.01 General

The District will inspect all sewer facilities prior to acceptance and again just prior to the expiration of the 1-year guarantee.

When a section of pipe of a length deemed adequate by the Design Engineer is ready for testing, the pipe shall be flushed and then tested in accordance with the applicable testing method as described herein. Suitable temporary testing plugs or caps shall be installed. All necessary pressure pumps, pipe connections, meters, gauges, water, weirs, bulkheads, and other necessary equipment and all labor required for carrying out these tests shall be furnished. The Design Engineer shall notify the District at least 48 hours prior to any testing so that it may, at its option, have a representative present during the testing.

Gravity sewers shall be tested in accordance with the Hydraulic Infiltration/Exfiltration Test as described herein or, at the Contractor's option, in accordance with the Low Pressure Air Test as described herein. Additionally, PVC Gravity sewers shall be tested for deflection as described herein. Force mains shall be tested in accordance with the Pressure and Leakage Test for Force Mains as described herein.

If the District Engineer so desires, the first section of any line between two manholes shall be tested as soon as possible after backfilling has been completed. If such tests appear to be satisfactory and acceptable, progressive testing of completed sections of the lines may be deferred at the option of the District's Engineer, and at the request of the Contractor, until all pipe has been laid and before final acceptance. However, if permitted, this will not constitute a waiver of any of the tests or the leakage requirements.

Sections of pipe tested for infiltration and exfiltration prior to completion of the project shall be subject to a final inspection at completion of the project, and also subject to additional leakage tests, if warranted in the opinion of the District Engineer.

If the section fails to pass the applicable tests, the Contractor shall do everything necessary to locate, uncover and repair or replace the defective pipe, fitting or joint, all at his own expense. Additional testing will be required to assure passage of the test.

#### 140.02 Hydraulic Infiltration/Exfiltration Tests

Upon completion of a section of the sewer, the pipe shall be dewatered and tested to measure the infiltration for at least three (3) consecutive days. Test section shall be from manhole to manhole. Longer test sections may be used with the approval of the District Engineer.

The amount of infiltration/exfiltration including manholes, "Y" branches and connections shall not exceed 10 gallons per inch diameter per mile of sewer per 24 hours for clay.

For making the infiltration tests, underdrains, if used, shall be plugged, well points and other groundwater drainage shall be stopped to permit the groundwater to return to its normal level. Infiltration shall be measured by the use of weirs designed specifically for this purpose or other acceptable means approved by the District Engineer.

As required, suitable bulkheads shall be installed to permit the test of the sewer.

Where the crown of the pipe is below the natural groundwater table at the time and place of testing, the pipe shall be tested for infiltration. Suitable watertight plugs shall be installed and section of pipe to be tested shall be pumped dry before start of test. Where the crown of the pipe is above the natural water table, the pipe shall be tested for exfiltration by installing necessary plugs and filling pipes and manholes with water and maintaining a static head of water of a minimum of two feet above the crown of the pipe during the test. Exfiltration tests shall be conducted on main lines and lateral lines, unless waived by the District Engineer. The water level of internal pressure to be used for exfiltration test shall be determined by the Design Engineer.

The sewers shall pass the applicable test before any connections are made to buildings or to active sewers.

#### 140.03        Pressure and Leakage Test for Force Mains

Except as otherwise directed by the District, all pipelines shall be given combined pressure and leakage tests in sections of length approved by the District's Engineer. The Contractor shall furnish and install suitable temporary plugs or caps; all necessary pressure pumps, pipe connections, meters, gauges, and other necessary equipment; and all labor required. The Design Engineer shall witness all tests.

Subject to approval of the Design Engineer and provided that the tests are made within a reasonable time considering the progress of the project as a whole, and the need to put the section into service, the Contractor may make the tests when he desires.

The section of pipe to be tested shall be filled with water of approved quality and all air shall be expelled from the pipe. If air release valves are not available at high points for releasing air, the Contractor shall make the necessary excavations and do the necessary backfilling and make the completion of the test.

The section under test shall be maintained full of water for a period of 24 hours prior to the combined pressure and leakage test being applied.

Two pressure and leakage tests shall be conducted for each pipeline segment. The first test shall be conducted at the average working pressure of the pipeline segment. The second test shall be conducted at a test pressure of 100 pounds per square inch.

The pressure and leakage test shall consist of first raising the water pressure (based on the elevation of the lowest point of the section under test and corrected to the gauge location) to the specified pressure. If the Contractor cannot achieve the specified pressure and maintain it for a period of one hour with no loss of pressure and no additional pumping, the section shall be considered as having failed to pass the pressure test. The District may require that the pressure and leakage test be run in accordance with AWWA C-600 Standards, latest revision (Four Hour Test).

**END OF SECTION 140**

## SECTION 150

### SUBMERSIBLE LIFT STATIONS

#### 150.01 Scope

It is the intent of this standard is to provide component requirements and general design guidelines for submersible wastewater lift stations. This standard shall be used in conjunction with Standard Details SD-31 through 35 and referenced standards for complete submersible wastewater lift station requirements.

This specification typically defines requirements for 20HP and smaller lift stations. Lift stations greater than 20 HP, serving critical infrastructure or performing as a repump station may require alternate design criteria including variable speed, tri-plex configuration, permanent standby emergency power and PLC control. These additional design criteria will be defined by Engineering Services during the design.

#### 150.02 Site

Lift station sites shall be provided with a minimum 40' x 40 lift station easement. Variations on the easement shall be considered on a case by case basis where access, maintenance and bypass operations can be accommodated with alternate configurations acceptable to the District and approved by Engineering Services.

The lift station site and access shall be set at proper elevations and configurations such that access and maintenance to the station will not be impaired by flooding, excessive road grades, swales, walls or landscaping. A lift station site plan indicating all topographical features, rights-of-way, easements and adjoining contiguous areas shall be submitted to the District for approval..

All above or at grade facilities shall be above the 1% Annual Chance Flood (100-year flood) zone, as shown on Flood Insurance Rate Maps (FIRMs). Site and lift station plans shall include the 100-year flood elevation.

#### 150.03 Power

The Contractor shall coordinate with and pay all fees, deposits, and service costs to Florida Power and Light Corp. to provide a three phase, 480V or 240V underground power service to the new lift station site. The transformer for the station shall be located not further than 25 feet from the nearest station easement line.

The power meter for the lift station shall be located on the lift station site, installed on the District's standard control panel rack.

150.04      Lift Station Standard Equipment

A list of standard lift station equipment is given below. This list is not all inclusive and the Contractor shall supply all other equipment necessary for complete working installations. The lift station shall include:

Two (2) explosion proof submersible type sewage pumps with 316 stainless steel guide rails, base plates and all accessories.

Two (2) discharge lines with swing check valves and plug valves and emergency tap connection

Instrumentation/control system, (requirements vary on station size)..

One (1) electrical control panel, NEMA 4X, to house electrical equipment, pump controls, alarms and protection.

One (1) wet well.

One (1) valve vault.

Concrete covers with aluminum access hatches and safety grates

Influent drop assemblies

Permanent standby generator and ATS, (requirements vary on station size).

Radio or Cellular Telemetry System

Coatings

Concrete pads

Landscaping/site screening

The wet well structure shall receive a minimum 1.0-inch thick calcium aluminate corrosion barrier such as Sewper Coat, Strong Seal, Refratta HAC 100 or approved equal, and installed per the manufacturers recommendations.

One (1) influent (collection) manhole structure with piping connecting to the wet well structure. The distance between the collection manhole and the wet well shall be no more than 50 feet.

150.05      Pumps and Motors

The pumps shall be capable of handling grit and raw unscreened sewage. The design shall be such that the pump unit will be automatically and firmly connected to the discharge piping when lowered into place on its mating discharge connection, permanently installed in the wet well. The pump shall be easily removable for inspection or service requiring no bolts, nuts, or other fastenings to be disconnected.

All major parts, such as the stator casing, oil casing, sliding bracket, volute, and impeller shall be of gray iron. All surfaces coming into contact with sewage shall be protected by a coating resistant to sewage. All exposed bolts and nuts shall be of stainless steel.

Pump faces shall be machined to accept a sacrificial plate between the pump face and seat. The sacrificial plate shall be manufactured from 1/4" brass plate, bolted to the pump face and removable/replaceable.

A wear ring system shall be installed to provide efficient sealing between the volute and impeller.

The impeller shall be hard alloy gray cast iron of non-clogging design capable of handling solids, fibrous material, heavy sludge, and other matter found in normal sewage applications. The impeller shall be constructed with a long throughout without acute turns. The impeller shall be dynamically balanced. The impeller shall be a slip fit to the shaft and key driven. Non-corroding fasteners shall be used.

Each pump shall be provided with a mechanical rotating shaft seal system running in an oil reservoir having separate, constantly hydro-dynamically lubricated and lapped seal faces.

The lower seal unit between the pump and oil chamber shall contain one stationary and one positively driven rotating tungsten-carbide ring.

The upper seal unit between the oil pump and motor housing shall contain one stationary tungsten-carbide ring and one positively driven rotating carbon ring. Each interface shall be held in contact by its own spring system supplemented by external liquid pressures. The seals shall be easily inspected and replaceable.

The shaft sealing system shall be capable of operating submerged to depths of, or pressure equivalent to, 65 feet. No seal damage shall result from operating the pumping unit out of its liquid environment. The seal system shall not rely upon the pumped media for lubrication.

A sliding guide bracket shall be an integral part of the pump unit. The volute casing shall have a machined discharge flange to automatically and firmly connect with the cast iron discharge connection, which when bolted to the floor of the sump and discharge line, will receive the pump discharge connection flange without the need of adjustment, fasteners, clamps or similar devices.

Installation of the pump unit to the discharge connection shall be the result of a simple linear downward motion of the pump unit guided by no less than two guide bars. No other motion of the pump unit, such as tilting or rotating, shall be acceptable. Sealing of the discharge interface by means of a diaphragm, O-ring, or other device will not be considered acceptable or equal to a metal to metal contact of the pump discharge flange and mating discharge connection specified and required. No portion of the pump unit shall bear directly on the floor of the wet well. There shall be no more than a 90-degree bend allowed between the volute discharge flanges and station piping.

The pump motor shall be housed in an air or oil filled watertight casing and shall have moisture resistant Class "F" 155-degree C insulation. Oil filled casing shall be filled with transformer oil, quality BP Energol J50, or Shell Diala D or DX. The motor shall be a minimum of 5 BHP, rated for operation at 1700 or 1750 rpm, on a 230V, 3-phase, 60 hertz power supply. The cable entry water seal design shall be such that precludes specific torque requirements to insure a watertight and submersible seal. Epoxies, silicones or other secondary sealing systems shall not be required or used. The cable entry junction box and motor shall be separated by a stator lead sealing gland or terminal board which shall isolate the motor interior from foreign materials gaining access through the pump top.

Pump motor cable installed shall be suitable for submersible pump applications and this shall be indicated by a code or legend permanently marked on the cable. Cable sizing shall conform to NEC specifications for pump motors and shall be of adequate size for the motor rating. Pump motor cable shall be ample length to reach the rack mounted panel. Cable length to be determined by the site plans.

The pump cable shall have 90 degree C rated insulated material based on 40 degree ambient and shall have anti-roping and anti-wicking design. All mating surfaces of major parts shall be machined and fitted with nitrile O-rings where watertight sealing is required. Machining and fittings shall be such that sealing is accomplished by automatic compression in two planes and O-ring contact made on four surfaces, without the requirement of specific torque to affect this. Rectangular cross sectioned gaskets requiring specific torque limits to achieve compression shall not be considered adequate.

Tolerances of all parts shall be such that allows replacement of any parts without additional machining required to insure sealing as described above. No secondary sealing compounds, greases, or other devices shall be used.

Each unit shall be provided with an adequately designed cooling system. Thermal radiators integral to the stator housing, cast in on unit, are acceptable. Where water jackets along or in conjunction with radiators are used, separate circulation shall be provided. Cooling media channels and ports shall be no-clogging by virtue of their dimensions. Provisions for external cooling and flushing shall be provided.

Pump and motor assemblies shall meet NEC and NFPA requirements for explosion proof installations in Class 1, Division 1, Group D environments.

The pumps and motors shall be manufactured by FLYGT Corporation.

150.06            Control Panel

This section is specific to single speed, duplex lift stations with float control, for variable speed, PLC controlled stations see Section 161.

The Contractor shall furnish and install a heavy duty type District Standard control panel as shown on the plans and specified here, as manufactured by Sta-Con Incorporated, QCI, or approved equal, and in accordance with the detail sheets SD-31 through 35.

The control panel shall contain all the remote electrical equipment necessary to provide for the operation of the pumps. The panel shall start and stop the pumps in the wet well.

The control panel shall start the “lead” pump when the liquid level rises to a preselected elevation “D”. If the influent rate exceeds the capacity of the “lead” pump, the lag pump shall be started when the liquid level rises to a preselected elevation “C” (higher than “D”). If the liquid level rises to a preselected elevation “B” (higher than “C”), the high level alarm shall be activated. When the liquid level falls to a preselected elevation “E” (lower than “D”), both pumps shall be stopped.

The control panel shall be contained in a single enclosure, fabricated of not less than 14-gauge 316 stainless steel, NEMA 4X construction. The door shall be formed with minimum lip of 3/4” and full height hinged. Closure mechanisms shall be No. 3 S.S. fasteners with No. 3 keepers as manufactured by Simmons Fasteners, or approved equal.

The interior door shall be constructed of .080-inch thick 6061-T6 aluminum. The interior and exterior doors shall be provided with a stop mechanism to hold the doors open which working in the panel. A rain shield shall be provided.

The control panel shall include the following items plus any other items shown on the plans or required for a complete, operational installation.

Circuit breakers with combination full voltage motor Starters for each pump.

“Hand-Off-Auto” selector switch for each pump, heavy duty oil tight type (toggle switches will not be acceptable).

Automatic pump alternator with test switch.

Duplex receptacle with 15-amp circuit breaker 115V GFI.

Control power circuit breaker.

Main circuit breaker.



Emergency power minimum 100-amp circuit breaker and 100-amp, 4 wire, 3 pole, reverse service generator receptacle. Emergency power to match main breaker size.

Lightning arrestor, 3-phase.

Surge capacitor.

Phase monitor, to prevent energization of pump motors in the event of phase failure or reversal or low voltage.

Indicating light for each level regulator (float switch).

“Running” indicating light for each pump.

Elapsed time meter for each pump, 2-1/2”, 6-digit non-reset.

Emergency/High level alarm light and horn, 12 VDC with battery back-up.

The panel shall include back-up circuitry to permit one pump to operate with a normal drawdown in the event of failure (open circuit) of the “stop” level regulator.

Spare parts to be furnished with the panel include:

- 2 - 120V Relays
- 1 - Alternator
- 1 - Phase Monitor
- 12 - Lamps
- 12 - Fuse Links
- 1 – Intrinsically Safe Barrier
- 1 – Alarm Controller

A copy of the panel wiring diagram shall be attached to the inside of the outer panel door. An extra copy shall be given to the District.

The basic components and layout of the control panel are shown on Standard Details 31, 32, 33 and 34.

Substitutions of these components will be permitted for approved equal, interchangeable products upon obtaining specific written approval from the District.

150.07      Telemetry

Lift stations shall be provided with a District standard radio telemetry system by Data Flow Systems. Telemetry systems shall provide monitoring and control for the following signals:

1. Digital
  - a. Power Fail
  - b. Auxiliary Power
  - c. High Level
  - d. Pump # 1 Fail
  - e. Pump # 2 Fail
  - f. Pump Run # 1
  - g. Pump Run # 2
  - h. Pump On # 1
  - i. Pump On # 2
  - j. Pump Off # 1
  - k. Pump Off # 2
  - l. Spare
  - m. Spare
2. Analog
  - a. Wet Well Level
  - b. Spare
  - c. Spare

An alternative cellular telemetry system may be available. Coordinate with the District's Director of Engineering Services for specifics.

150.08      Access Hatches & Fall Through Safety Prevention Systems

The wetwell and valve vault access hatch shall be single leaf design with a minimum clear opening at 36" x 48", but must also meet the minimum clear opening as required by the pump manufacturer. The frame shall be a minimum: 3" x 3" x 1/4" aluminum angles and the cover shall be 1/4" aluminum angles and the cover shall be 1/4" aluminum diamond pattern. The hatch shall be completed with anchor straps, automatic hold open arm and cover release, forged brass or stainless steel hinges with stainless steel pins, hasp and staple lock, flush type handles, upper guide holders and sensor cable holder. The cover shall be reinforced to withstand a live load of 300 lbs./sq. ft. unless in areas that may experience traffic. Hatches in traffic areas shall meet H-20 design loading criteria, at a minimum. Hinges shall be of the interior type.

For all stations 6' in diameter or larger, the Contractor shall provide fall through safety prevention systems. All systems will be of the grate type as manufactured by U.S.F. Fabrication, Inc., able to withstand a pedestrian load of 300 lbs/sq. ft.. The safety grate must be constructed of aluminum and/or stainless steel. All hardware must be of 316 stainless steel construction.

The configuration of the hatch and safety grate shall be such that opposing sides of the wetwell opening are protected when the safety grate is in the upright position and safety chains from the safety grate to the hatch shall be provided to protect adjacent sides.

10' diameter and larger wetwells and tri-plex stations will require custom hatch and safety grate designs to be determined in coordination with the District's Director of Engineering Services during design.

#### 150.09 Floats

24V float switches with internal single pole mercury switch shall be installed in the wet well to control the operation of the pumps with variations of liquid level in the wet well. The float switches shall be sealed in a polypropylene casing with a firmly bonded electrical cable protruding. Floats shall be Roto-Float type S as manufactured by Anchor Scientific Inc..

#### 150.10 Valves

See Section 130

#### 150.11 Pipe and Fittings

See Section 114 for HDPE pipe and fittings used in the wetwell. See Section 111 for ductile iron pipe and fittings.

#### 150.12 Wetwell and Valve Vault

See Section 121 and standard details SD-31

#### 150.13 Wet Well via Caisson Construction

Wet wells installed via the caisson method are allowed only with prior approval by the Loxahatchee River District. Final acceptance of the wet well by caisson method will only occur when it is determined that:

- Wet well has no structural damage, deep gouges and and/or cracks.
- Wet well has been installed at the design depths indicated.
- Wet well is plumb. The maximum deviation shall be 1/8" per foot of each precast section.
- Wet well tremie seal is leak free and there are no continually damp areas prior to the installation of the secondary pour.
- Wet well sections show no evidence of separation and that the structure has not settled.
- Wet well walls, specifically at the joints, are flush and without overhang.
- Wet well was installed in proper sequence.

If any of the above items are not met to the satisfaction of the District, the wet well will be rejected and it will be the contractor's responsibility to remedy the problem at his own expense. The contractor shall also provide a warrantee that the wet well will meet the above requirements for a 1-year period from the date of District acceptance.

#### 150.14        Submittals

The following submittals are required for approval prior to construction of the project.

1. Lift Station Calculations to include
  - a. Average Daily Flow
  - b. Peak Hour Flow
  - c. System Head Curves
  - d. Wetwell Cycle Time
  - e. Anti-Flotation
2. Lift Station Site Plan
3. Pump and Motor
4. Pipe and Fittings
5. Valves
6. Concrete Structures
7. Control Panel – complete detailed design including electrical schematic, panel layout, bill of materials
8. Panel Rack
9. Base Plates
10. Rails, Brackets and Adapters
11. Conduit and Cable
12. Aluminum Hatches and Safety Grates

Detailed wiring diagrams of the entire installation including main power supply, pump motors, control circuits, alarm circuits, and metering circuits shall be submitted. The diagrams shall include schematic and connection wiring diagrams.

Four (4) copies of detailed installation drawings including wiring diagrams, pump curves and maintenance and operating manuals shall be submitted to the District at the time of initial start-up.

#### 150.15        Services to be Furnished by Manufacturer of Equipment

The services of a factory-trained representative shall be furnished for the lift station start-up. The representative shall check all electrical components, wiring, and pump operations.

#### 150.16        Operation and Maintenance

Upon completion and successful startup of the lift station the District will be provided with two copies of the lift station operation and maintenance manual. The manual shall include operation and maintenance detail including service intervals for all equipment provided with the lift station.

Operation and maintenance manuals shall also include AS-BUILT drawings for the lift station, control panel, wiring schematics and appurtenances.

150.17        Warranty

The pump manufacturer shall warrant the pumps for a period of five (5) years from the date of pump manufacturer's start-up. The warranty shall include a minimum 100% coverage of the manufacturer's shop labor and parts for the first eighteen months, then 50% coverage through the third year, and then 25% coverage through the fifth year.

**END OF SECTION 150**

## SECTION 151

### LOW PRESSURE SEWER SYSTEMS

#### 151.01 General Intent

It is the intent of the District to provide sanitary sewer service to the citizens, businesses, and industry of the area in a manner which maximizes use of existing facilities, minimizes environmental damage, and provides solutions to existing problems.

Gravity collection systems with central lift stations are the preferred methods of collecting and transporting sewage to the regional facilities. All property owners should anticipate connection via these conventional facilities unless otherwise directed by the District.

The District recognizes that the construction of gravity sanitary sewer lines is not conducive to all areas, and that utilization of an alternative system may be necessary to provide access to regional facilities.

The District may at its sole discretion allow or direct the utilization of LPSS where it is determined to be in the best interest of the District. The District may direct the use of LPSS to minimize the impacts of gravity sewer construction upon existing neighborhoods or upon environmentally sensitive areas.

The use and implementation of LPSS shall be at the sole discretion of the District and no installation shall be considered as a precedent for justifying the acceptance of LPSS in a similar or like situation.

#### 151.02 Administration

The administrative procedures for construction are set forth in the latest revision of the District Construction Standards and Technical Specifications and shall be adhered to unless specifically modified in writing by the District.

#### 151.03 Utilization

##### 151.03.1 LPSS for Existing Developments

For the purpose of this section, the term "existing developments" shall be considered as those areas which have previously developed on septic tanks to the extent that a substantial portion of the subdivision is now built out; or, under less prevalent circumstances, an area which has received site plan approval and is plated/subdivided based upon use of septic tanks.

The criteria for the District's determination of whether the use of LPSS is warranted includes, but is not limited to: existing developments of less than 40 homes, or in areas of high water tables, or in areas where work space for construction activities is unreasonably restricted or in areas where

available gravity collection lines have not been provided by prior construction.

Existing gravity sewer systems will be utilized to the maximum extent possible; however, LPSS may be considered in existing neighborhoods where gravity construction would be unreasonably restricted in the opinion of the District Engineer.

#### 151.03.2 Community Grinder Systems

The use of a community grinder system is a merge of a LPSS system and a traditional gravity collection system, in that there are instances where the District would allow “grinder systems” in conjunction with small gravity system to serve a community. In accordance with Section 151.01 above, the utilization of smaller “grinder systems” with limited gravity collection systems will be encouraged in new developments where environmental concerns would be adversely impacted by the construction of a traditional non-clog lift station and/or deep gravity lines, at the sole determination of the District.

Grinder systems could be considered for:

- New Development – areas of less than 15 homes, with a suitable site for a grinder station.
- Existing Development – areas of less than 20 homes, both sides of street participating, and cost is not greater than 200% of LPSS, unless specifically requested by property owners.

#### 151.04 Responsibility

##### 151.04.1 District

A low pressure sewer system may consist of one or more pump stations. A pump station shall be considered as the individual pumping unit which serves a single residence, or a commercial or industrial customer. In the latter cases, the unit may contain two pumps (duplex).

All plans for the construction of any portion of an LPSS shall be submitted to the District Engineer for review and approval.

All LPSS facilities which are located within public rights-of-way shall be conveyed to the District for operation and maintenance.

Any facility, associated with an LPSS, which is located outside of the private property being served, must be within a dedicated easement or right of way. The easement shall be conveyed to the District.

The District shall be responsible for the operation and maintenance of all facilities (force mains, valves, etc.) within rights-of-way, or dedicated platted utility easements which serve more than one unit.

Property owners must execute a License Agreement for District maintenance of residential and low flow nonresidential pump stations.

#### 151.04.2 Residential or Non-residential User Responsibilities

Each individual residential or low flow non-residential user of the LPSS system shall provide his own pump station, electrical service, force main and connection to the District owned collection/transmission lines. The District shall be responsible for the operation and maintenance of all residential and 3-phase non-residential low flow equipment serving his individual property, whether located on his property or in easements off of his property. The residential or nonresidential user shall be responsible for the installation of the pump station, control panel, force main valves, and all appurtenances which are a part of the system solely serving the individual user. Maintenance will be provided in accordance with the License Agreement provisions.

Low Pressure Systems for commercial and single phase low flow non-residential use shall: 1) require a duplex grinder pump system, and 2) be operated and maintained by the property owner in accordance with P.B.C. Health Dept./Florida DEP requirements

The user shall provide electrical power from his meter to the control panel, and all operating costs shall be users responsibility.

#### 151.05 Submissions and Approvals

All installations of individual units shall be reviewed and approved by the District Engineer prior to construction. The District Engineering Department shall be notified at time of installation of the pumping unit and prior to connection to the District line. Connection excavations shall remain open and protected until such time as an inspection has been performed and a satisfactory connection is made.

All installations shall be made in accordance with District Technical Specifications, and local plumbing and electrical codes, and the regulations of the Florida Department of Environmental Protections.

Submittals for area lines which will be taken over by the District for operation and maintenance shall be made by a Professional Engineer, registered in the State of Florida. The District may require a hydraulic analysis from the Professional Engineer to determine if the existing District infrastructure has the capacity to accept new connections. Once hydraulic capacity has been determined available, six (6) sets of signed and sealed construction plans shall be submitted for approval. The construction shall also be inspected and certified by a Florida registered professional engineer upon completion.

Submittals for individual installations shall include a shop drawing of the pump station and control panel, and an as-built drawing showing tie-in dimensions of the force main, valves, and any electrical conduits.

The use of pumping units is restricted to specific makes and models for which the District will maintain a limited spare parts inventory for emergency situations only.



#### 151.06 Definition

A low pressure sewer system is defined as a means of conveying sewage by individual pumping units through a small pressurized force main to a discharge point which can be part of an existing force main or gravity system.

#### 151.07 General System Design Considerations

The following particulars should be considered in the design of any proposed low pressure system:

1. Geographical location.
2. Type of development - number of residences.
3. Topography of service area (where applicable).
4. Layout of existing or proposed service area.
5. Projected sewage flows.
6. Location of nearest existing sewer facility.
7. Soil and water table information.
8. Availability of electric power.

##### 151.07.1 System Layout and Alignment

The pressure sewer system should be designed so that all contributory lines are branched into a main collector. "Looping" and "dead-endings" of macerated sewage in remote areas of the system shall be avoided.

Pressure lines should be laid out to provide runs as short as possible with a minimum of major change in direction.

In order to facilitate maintenance and repair, force mains should be laid outside the limits of pavement or heavy traffic areas.

All system lines shall be kept full, under a positive pressure head at all times. This can be maintained by locating the system terminus at the highest elevation, or by employment of a positive pressure control device at the terminus.

To minimize the number of potential air pockets, pressure lines should be installed on a continuously rising grade as much as possible to predetermined points where air release devices and cleanout ports can be installed in accordance with the Standard Details.

##### 151.07.2 Design Flow

As in any collection system, a pressure sewer system must be designed to effectively handle all sewage flow generated in the service area especially during times of peak flows.

Peak flow shall be determined by accepted sanitary sewer engineering principals and standards established by regulatory agencies. Proper design should assure that each contributing pump unit in the service area, no matter what its location or what other units are operating at the same time, will be able to deliver into the system during these peak flow system conditions at a rate sufficient to insure that there will be no sewage removal problem at any individual building or unit. A pumping rate in the range of 8-10 gal./min. is normally considered sufficient.

#### 151.07.3 Line Sizing and Velocities

Line sizing must be designed to insure that scouring velocities will occur in the system pressure lines at some regular interval. At the same time they must avoid excessive system pressures which can jeopardize the delivery capacity of any unit on the system.

To insure that scouring will occur during design flows, it is recommended that the velocities in the pressure lines be maintained in the 2-5 ft./sec. range at regular intervals.

Minimum service line and tap diameters for commercial connections shall be 2-inches. In the case of tying into an existing 2 or 2.5-inch main, a tee with a 2-inch outlet shall be cut in.

#### 151.07.4 Operation of Contributing Pumping Units

A most important design consideration is that the proper operation of any and each pumping unit on the system be assured during any flow conditions which could exist. This includes the most demanding maximum peak design flow which may be seldom, if ever, encountered (such as immediately following an extended power outage).

#### 151.07.5 System Flushing

Design shall provide for the ability to mechanically purge sewage from the system at regular intervals. Flushing connections to the force main system are shown in the Standard Details.

#### 151.07.6 Air Release

Design shall provide for relief of air at high points along the system. Valves and piping configuration is shown in the Standard Details.

#### 151.08 Pumping Units

The pumping units shall combine a centrifugal submersible pumping unit(s) with a patented grinding assembly which is capable of reducing sewage and its normal constituents (together with sticks, rubber, bones, rags, plastics, etc.) to a particulate slurry which can easily be transported through small diameter pipes.

The units shall be furnished complete with unit tank, electrical control panel, level controls, alarms, check and ball valves, and other necessary appurtenances as shown on the Standard Details.

Pumps shall be manufactured by Barnes and have a 1-1/4" vertical discharge outlet. Reference the District's low pressure sewer standard details (LP details) for information regarding pump models and configurations.

#### 151.09        Piping and Appurtenances

##### 151.09.1      Pipe

Schedule 40 PVC: Pipe shall be Type I, PVC 1120 with a hydrostatic design stress of 2000 psi for liquid at 73.4 F. Pipe shall conform to ASTM D 1785, ASTM F 480 and ASSTM D 2665.

HDPE: Pipe shall be PE 4710 with a minimum hydrostatic design stress of 800 psi for liquid at 73.4 F utilizing a 0.5 design factor. Pipe shall conform to ASTM 3035 and ANSI/AWWA C901.

##### 151.09.2      Valves and Cleanouts

Isolation valves shall be strategically placed along the pressure main at services, junction points, changes of direction, and recommended intervals along extensive straight runs (see LP Details). Isolation valves shall be ball type made of brass and be capable of operation with a 2" operating nut and be placed within a District approved valve box. Refer to the District's LP details for specifics on which isolation valves are not required to have a valve box.

Each pumping unit shall be isolated from the low pressure force main system by a PVC ball valve (service valve) and check valve, positioned at the street right-of-way line, inside of a service box (see LP details).

This service line will typically be 1.5 inches in diameter, set in a District approved meter box, at no more than 18" depths at the right of way line (see LP Details).

##### 151.09.3      System Wiring and Control

Each individual contributing pumping unit shall be connected by underground conduit to the individual home electrical power supply. This conduit may be laid in the same trench as the gravity service pipe to the unit tank. Wiring and conduits shall be installed in accordance with all applicable local codes and regulations.

Liquid level controls shall be a sealed mercury switch in an approved float ball. The switch shall be sealed for life with a heavy neoprene jacketed control cord permanently attached.

A high water activated alarm shall be supplied. An alarm light shall be mounted on the building or control panel in such a manner so that it will be visible to building occupants and from the contiguous street areas.

The electrical control panel shall consist of the following:

Corrosion Proof Enclosure  
NEMA 3R rating  
Hinged Access Panel  
Lockable Latch  
120V AC Control Voltage - single phase  
GFI Receptacle on dead front  
Audible Alarm  
Rated Disconnect Switch

The electrical control panel enclosure and its components shall be UL listed.

Typical wiring diagram is shown on the District's LP Details.

#### 151.09.4 Tanks and Covers

Tanks shall be constructed of polymer or reinforced fiberglass polyester resin and the minimum size shall be 30" x 60" for a simplex configuration. Interior surface to be 10-20 mil. thick gel coated to provide a smooth sealed surface. Lockable gasketed water tight covers shall be flat aluminum and capable of supporting a 300 lb. wheel load. The fiberglass tank shall have an integral anti-flotation flange which will anchor into a concrete collar designed to counteract uplift forces.

The wall thickness of the fiberglass tank shall be sufficient to withstand a water saturated sand load of 120 pcf with a safety factor of two (2) for all depths.

Inlet hubs shall be as shown on the District's LP details. All hardware shall be stainless steel and be leak proof sealed.

The cover (lid) shall be 2/3<sup>rd</sup>s hinged single leaf, rated at 300 lbs/sq. ft and be lockable. The lid shall be set at a minimum, six (6") inches above final grade.

Conduit opening shall be sealed with an approved duct seal.

Float and wire hanger bracket shall be stainless steel (Type 304).

All interior piping shall be Schedule 80 PVC. A PVC union on the horizontal discharge pipe shall allow for the quick removal of the grinder pump assembly. The discharge line inside the tank shall also have a 1.25 inch PVC ball type check valve located inside the tank.

**END OF SECTION 151**

## SECTION 152

### ADOPTION OF STANDARDS

The Loxahatchee River Environmental Control District Manual of Minimum Construction Standards and Technical Specifications were initially adopted and promulgated by the Governing Board in April, 1983.

The current edition was ratified by the Loxahatchee River Environmental Control District's Governing Board, on May 17, 2018, with a \_\_\_\_\_ vote as follows:

“THAT THE DISTRICT GOVERNING BOARD ratify the Loxahatchee River Environmental Control District's “Manual of Minimum Construction Standards and Technical Specifications”, as of May 17, 2018, and authorize the District Engineer and Executive Director to update the Construction Standards and Technical Specifications from time to time, and periodically present it to the Governing Board for ratification.”

<u>Board Member</u>	<u>Vote</u>
Mr. Snyder, Chairman	“Aye”
Mr. Rostock, Vice-Chairman	“Aye”
Dr. Rockoff, Treasurer	“Aye”
Mr. Boggie, Secretary	“Aye”
Mr. Silverman, Assistant Secretary/Treasurer	“Aye”

D. Albrey Arrington, Ph.D.  
Executive Director  
Loxahatchee River Environmental Control District

**END OF SECTION 152**

## SECTION 161

### VARIABLE SPEED/PLC CONTROL PANELS

#### 161.01 General

This section provides for design, construction, installation and start-up of a custom power and control panel by a qualified panel manufacturer. The panel and components shall comply with the requirements of this specification and other sections and standard details of the District's Manual of Minimum Construction Standards and Technical Specifications.

This section is generally used for variable speed submersible wastewater lift stations greater than 20HP

#### 161.02 Submittals

Submittals for the power and control panel shall include but not be limited to the following:

1. Panel materials of construction, layout and dimensions.
2. Anchoring details to concrete slab
3. Wind load calculations (if required by permitting authority)
4. Scaled dead front layout
5. Scaled back plan layout
6. Scaled component layout
7. Power, Instrumentation, Radio Telemetry and Control wiring schematics

#### 161.03 Panel

The control panel shall be NEMA 4X ground mount enclosure with double doors and leg kit for floor standing. The panel shall be minimum thickness 12-gauge 316 stainless steel, enclosure and doors. The doors shall be formed with minimum lip of 3/4", full height concealed hinges, stainless steel door clamps on non-hinged sides and pad-lock hasps. The center post shall be removable for full access to the panel interior. A rain/drip ledge shall be provided over the doors. Sun shields shall be provided on top, east, west and south facing sides.

The interior doors/dead fronts shall be construction of minimum 0.080 inch 6061-T6 aluminum.

Both exterior and interior doors shall have a mechanism to hold the doors open.

The panel shall be manufactured by Hoffman or approved equal.

The control panel shall be designed and tested in conformance with UL 508.

## 161.04      Operating Protocol

The power and control panel shall provide for manual and automatic operation of the lift station pumps utilizing an ultrasonic level controller, programmable logic controller and variable speed drives. The station operating protocol shall be as follows.

### 1. Operating Protocol 1: Level Control

- a. ELEV A all pumps off
- b. ELEV  $\geq$  B lead pump on. speed adjust to maintain level
- c. ELEV  $\geq$  C lag 1 pump on. lead and lag 1 match speed and adjust to maintain level
- d. ELEV  $\geq$  D lag 2 pump on. lead, lag 1 and lag 2 match speed and adjust to maintain level
- e. ELEV E all pumps on 100% speed
- f. LEVEL DECREASING/MATCHED PUMP SPEED BELOW 50% for X seconds lag 2 off. Lead and lag 1 match speed adjust to maintain ELEV C.
- g. LEVEL DECREASING/MATCHED PUMP SPEED BELOW 50% for Y seconds lag 1 off. Lead adjusts speed to maintain ELEV D.

### 2. Operating protocol 2: Constant Speed

- a. ELEV INCREASING
  - i. ELEV  $\geq$  B lead pump on. N% speed.
  - ii. ELEV  $\geq$  C for X seconds. Lag 1 on. N% speed.
  - iii. ELEV  $\geq$  D for X seconds. Lag 2 on. N% speed.
- b. ELEV DECREASING
  - i. ELEV  $\leq$  C for X seconds. Lag 2 off.
  - ii. ELEV  $\leq$  B for X seconds. Lag 1 off.
  - iii. ELEV  $\leq$  A for X seconds. All pumps off.

### 3. Operating protocol 3: Manual/Hand

- a. With the HOA selector switch in Hand the selected pump shall turn on and speed be manually adjusted through the AFD. In Hand, all alarms shall function, but pump operation will not be prevented except for specific pump manufacturer alarms in place to prevent hard to the pump and/or motor.

### 4. Alarm Functions

- a. With the station in Hand, Off or Auto the alarm functions shall be fully operable.
- b. Alarms shall be available for the following
  - i. Pump Out of Service, each pump.
  - ii. Pump Fail to Run, each pump
  - iii. AFD Fault, each drive.

- iv. ATS Fault
  - v. Generator Fault
  - vi. UPS Fault
  - vii. Communication Fault
  - viii. Wetwell High Level
- c. The station shall have two high level alarm systems.
- i. Alarm 1: PLC based alarm system using a preset high level as read from the pressure transmitter. This alarm will activate onsite and offsite audible and visual alarms including the following.
    - 1. Audible Alarm Horn
    - 2. Visual Alarm Light
    - 3. High Level indicator located on the dead front inside the panel.
    - 4. Alarm indication on the Panel PC
    - 5. Alarm indication in the PLC
    - 6. Alarm indication to the DFS Radio Telemetry System
    - 7. Alarm indication in the Plant VT SCADA system.
  - ii. Alarm 2: Back up to Alarm 1 using a high level float switch inside the wetwell. This alarm will activate onsite and offsite audible and visual alarms including the following.
    - 1. Audible Alarm Horn
    - 2. Visual Alarm Light
    - 3. High Level indicator located on the dead front inside the panel.
    - 4. Alarm indication on the Panel PC
    - 5. Alarm indication in the PLC
    - 6. Alarm indication to the DFS Radio Telemetry System
    - 7. Alarm indication in the Plant VT SCADA system.
5. Emergency Standby Generator Limited Operation – On emergency standby generator power station operation shall be limited to 2 pumps.
6. Pump Off – Back Up Float System
- a. With the station in Auto a low level float in the wetwell will automatically shut off all pump operation until the high level float switch is activated.

Programming shall allow for operators to change all variables noted above through a simple interface via a laptop computer or the HMI.

161.05 Adjustable Frequency Drive:

Adjustable frequency drives shall be Eaton PowerXL DG1 Series. Drives shall be rated for 480V, 3 PH, 60 HZ. Drives shall be variable torque, pulse width modulated. Drive horsepower rating shall equal or exceed maximum pump motor horsepower requirements at any point on the pump curve.



The drive shall include a keypad interface that provides the following functions and displays at a minimum; Output frequency, frequency reference, motor speed, motor current, motor torque, motor power and motor voltage.

The drive shall include the following protective features, at a minimum; over current, over voltage, inverter fault, under voltage, input phase loss, output phase loss and under/over temperature.

The drive shall include the following field programmable I/O, at a minimum; DIGITAL: eight 24VDC digital inputs and eight 24VDC digital outputs including local/remote, drive ready, fault, running, overload, set speed, current. ANALOG: two 4-20 mA analog outputs, two 4-20 mA analog inputs.

The drive manufacturer shall provide services of a field service technician to assist in installation, setup and training.

Drives shall come with a minimum 12 month warranty.

161.06        Programmable Logic Controller: See Section 169

161.07        Uninterruptible Power Source (UPS)

Power and control panels shall be provided with an UPS for the control and telemetry system. The UPS shall be Eaton 5P Tower UPS with an Eaton Network Card-MS. The UPS shall be sized by the Contractor based on control and radio telemetry loads and to provide a minimum 10 minutes of backup power to these systems in the event of power failure.

The UPS shall provide power through an APC 120V 10 outlet rack mounted automatic transfer switch model number AP7750A. In the event of UPS failure the ATS shall switch to commercial power, if available.

161.08        Operator Interface/Panel PC

Power and control panels shall be provided with an operator interface/panel PC. The panel PC shall be Phoenix Contact USA Panel PC – VL2 PPC 2000 – 2400334:

Order Key **2400334/D29/A20/I32/R26/M52/M00/OS64/T00/S00/EF00/PS01**

The panel PC shall come with the following specific options:

1. Passive cooling system and fanless design for industrial applications
2. Panel PC (PPC): IP65 rating in front panel and IP20 rating in back. The control panel design shall ensure only IP65 areas are exposed when the dead front is closed.
3. Display shall be 47.0 cm / 18.5" TFT (Thin Film Transistor)
4. Screen resolution 1366 x 768 Pixel(s) (WXGA)
5. LED Backlighting

6. Intel® Celeron® N2930 1.83 GHz/2.16 GHz processor
7. Operating system shall be Windows® 10 IoT Enterprise LTSC 2015 (32-bit), Multi-language
8. RAM 4 GB DDR3 SODIMM
9. Mass storage - 2,5" SSD (MLC), 160 GB
10. Network 2x Ethernet (10/100/1000 Mbps), RJ45
11. Interfaces 1x COM (RS-232/422/485)
12. 4x USB 2.0
13. Monitor output 1x DisplayPort
14. Service life of battery 5 years
15. Environmental Conditions
  - a. Degree of protection IP65 (front), IP30 (back)
  - b. Ambient temperature (operation) 0 °C ... 45 °C (with HDD)
  - c. Ambient temperature (storage/transport) -40 °C ... 70 °C
  - d. Permissible humidity (operation) 5 % ... 95 % (non-condensing)
  - e. Permissible humidity (storage/transport) 5 % ... 95 % (non-condensing)
  - f. Power supply unit 24 V DC ±20 %

161.09      Ethernet Switch

Power and control panels shall be provided with an Ethernet switch to connect all networked devices including but not limited to the Panel PC, Uninterruptible Power Source and PLC. Ethernet switches shall be Allen Bradley Stratix 5700.

161.10      Ventilation

The panel shall include forced ventilation sufficient to maintain panel interior temperatures and conditions within the ranges set by the manufacturers of equipment located within the panel. Ventilation shall include filtration to prevent the entrance of dust, debris and water from entering the panel.

161.11      Level Transducer/Transmitter: See Section 169

161.12      Circuit Breakers:

Circuit breakers shall be Square D H-Frame sized per panel and pump power requirements.

161.13      Miscellaneous Materials and Requirements:

1. In general, except as specified otherwise in this section or the drawings, panel components shall comply with the Bill of Materials, on Sheet SD-34 of the District's Manual of Minimum Construction Standard and Technical Specifications.
2. One Duplex 15 amp 120 V GFCI receptacle with dedicated circuit breaker.
3. Two overhead fluorescent or LED lights with integral on/off switch mounted inside the panel behind each door in front of the dead front. The lights shall be 120V.

4. One “Hand-Off-Auto” selector switch for each pump, heavy duty oil tight type (toggle switches will not be acceptable).
5. One control power circuit breaker.
6. One main circuit breaker.
7. Secondary Backup Generator circuit breaker with Main Breaker Lockout.
8. Secondary Backup Generator receptacle.
9. Lightning arrestor, surge protector and phase monitor. The phase monitor shall lock out pump operation in the event of phase loss, reversal or low voltage.
10. One “RUN” indicator light for each pump.
11. One “FAIL” indicator light for each pump.
12. One Elapsed time meter for each pump, 2-1/2”, 6 digit non-resettable.
13. Independent 12VDC High Level Alarm System -
  - a. Alarm light, 12 VDC, with Flasher, outdoor type mounted on top of the control panel.
  - b. Alarm Horn, 12 VDC, outdoor type mounted on side of control panel.
  - c. High Level Alarm Circuitry to include high level float in the wetwell. Alarm circuit to match the District Standard, including the intrinsic safe circuit in the wetwell.
  - d. This alarm shall act independently from the PLC
14. A copy of the panel wiring diagram asbuilts and bill of materials shall be attached to the inside of the outer panel door. An extra copy shall be given to the District.

Spare parts to be furnished with the panel include:

- 2 - 120V Relays
- 1 - Alternator
- 1 - Phase Monitor
- 12 - Lamps
- 12 - Fuse Links
- 1 – Intrinsically Safe Barrier
- 1 – Alarm Controller

#### 161.14      System Integration

System integration shall be performed by

Frank Sczurek, Process Analyst  
Process Control Consultants  
PO Box 1174  
Loxahatchee, FL 33470

Phone: 561-791-1511  
Email: [procon@comcast.net](mailto:procon@comcast.net)

System integration shall include integration of the adjustable frequency drives, level transmitter, level transducer, programmable logic controller, uninterruptable power source, generator

controller, panel PC, automatic transfer switch, Data Flow Systems RTU and the District's VT Scada System for a fully functional system capable of implementing the required operating protocol and monitor/control functions as detailed in the specifications and the System Block Diagram.

System integration shall include screen development. At a minimum the following screens shall be provided at the Panel PC.

1. Overview – shows diagrammatic representation of the lift station pumps, drives, wetwell, generator and ATS and include equipment status and alarm and HOA functions. This screen shall also display, at a minimum, pump speed, pump hours, wetwell level, power source, voltage and current.
2. Setup Screen – allows setup of station parameters to include lead, lag, standby selection, time delays, tandem pump operation criteria, pump speed limits, operating levels and alarm levels,
3. Alarm/Fault Screen – displays a complete list of programmed alarms, indicates current/active alarm, allows alarm acknowledgment, allows setup of alarm parameters.
4. Trend Screen – Provide trending for lift station parameters including pump speed, wetwell level, estimated flow (based on correlation between pump speed, pump head and pump curve).

The following minimum screens shall be provided in the Plant VT SCADA system. Screens shall conform in style and function to the District's existing VT SCADA screens.

1. Station Status
2. Historical Trending

#### 161.15 Radio Telemetry

The power and control panel shall include dry contacts for the radio telemetry unit. Dry contacts shall be provided for all I/O listed below.

1. Pump Status
2. Pump Fail
3. Pump Call to Run/Off
4. Commercial Power
5. Auxiliary Power
6. High Alarm – back up float
7. Generator General Alarm
8. Generator Low Coolant
9. Generator Fuel Alarm
10. Generator Fail
11. Pump Speed
12. Pump Disable
13. Wetwell Level
14. 2 Spare Digital
15. 2 Spare Analog

**END OF SECTION 161**

## SECTION 162

### EMERGENCY STANDBY DIESEL GENERATOR SET

#### 162.01 General

The generator shall provide emergency power to the lift station adequate to operate the station and all appurtenances. A detailed sizing report shall be submitted for approval. The generator set shall be 130 C (266 F) temperature rise at 0.8 PF, 480/277V, 3 phase, four wire at 500' above sea level and ambient temperature 25C (77 F). The generator set shall be EPA certified for this specific application (permanent standby emergency power) but not have less than an EPA Tier III emission certification.

The generator set shall include an automatic transfer switch, battery charger, batteries, sound attenuating/hurricane rated/weather resistant enclosure and exhaust silencer and come as a complete package from the manufacturer.

Work shall also include a generator sizing report based on design loads detailed in the contract including pumps, controls, instrumentation, lightening and miscellaneous loads verifying manufacturers concurrence with the above sizing.

#### 162.02 Applicable Codes, Standards and Specifications

The installation shall comply with all applicable rules, regulations, and ordinances of the following:

- National Electric Code (NEC)
- Occupational and Safety Health Standards (OSHA)
- Florida Building Code (FBC)
- National Fire Prevention Association (NFPA)
- Underwriters Laboratory (UL)
- International Standardization Organization (ISO)
- National Electrical Manufacturers Association (NEMA)
- American National Standards Institute (ANSI)
- Institute of Electrical and Electronics Engineers (IEEE)
- Environmental Protection Agency (EPA)
- Town of Jupiter
- Palm Beach County

#### 162.03 Submittals

The generator set submittal shall include drawings and schematics that fully depict the product being provided. Submittals shall include the following:

- A. Generator sizing report
- B. Generator set plans and elevations.
- C. Enclosure including plans and elevations.
- D. Fuel tank including plans and elevations.
- E. Engine, combustion air, exhaust, fuel, lubrication and cooling performance

- specifications.
- F. Alternator specifications.
- G. Fuel consumption rates.
- H. Generator set rating (Prime at 105 C temperature rise)
- I. Exhaust silencer.
- J. Generator breaker
- K. Battery charger.
- L. Controller.
- M. Enclosure including sound attenuation, wind rating and weather rating (wind driven rain proof).
- N. Tier Rating.
- O. Start-up report
- P. Factory production testing.

#### 162.04 Acceptable Manufacturers

The generator set, fuel tank and enclosure shall be supplied by a single manufacturer. The generator set shall be manufactured by Caterpillar, Kohler, Cummins/Onan, Detroit Diesel or Generac.

#### 162.05 Warranty

The generator set and ATS shall have a 1-year warranty from the date of acceptance by the District.

#### 162.06 Diesel Engine Generator Set

The engine shall be water-cooled four-stroke compression ignition diesel and rated to drive the generator set after derating for elevation (altitude) and temperature.

Voltage regulation shall be within 5% of rated voltage at constant load. Frequency regulation shall be within 3%. Total harmonic distortion shall not exceed 5%.

When loaded voltage dip shall not exceed 20% and frequency dip shall not exceed 10%. Recovery time shall not exceed 3 seconds.

The generator shall be synchronous, four pole, revolving field, permanent magnet, drip proof, air cooled and direct connected to the engine. Insulation shall be Class H and suitable for use in wind driven rain and salt spray environments. Temperature rise shall not exceed 130 C at standby rating and 105 C at prime rating.

- A. Governor: The generator set shall be equipped with an electronic governor that maintains frequency regulation within 3%.
- B. Fuel System: The fuel system shall be equipped with a 5-micron fuel filter/water separator. The filter shall be sized to handle 125% of the fuel flow at full load. The fuel pump shall be engine driven, positive displacement and mechanical.

The fuel tank shall be sized for min. 72 hour run time at full load based on published fuel consumption rates provided by the generator set manufacturer. The fuel tank shall be belly style installed beneath the enclosure but not form a structural member of the enclosure. Fuel fill shall be readily accessible without opening the enclosure. The tank shall be fitted

with a local, mechanical fuel gauge. The tank shall be double walled with inspection port for the interstitial space.

- C. Space Heater: The generator shall have a 120V space heater sized to maintain the generator windings above temperatures typical in the installation location.
- D. Jacket Water Heater: The generator shall have a 120V jacket water heater sized to maintain the engine block at 90 F.
- E. Battery Charger: The generator shall have a 120V powered 12V or 24V battery charger with trickle charge/maintain function and standard charging capability. The battery charger shall be sized based on charging requirements and sizes of batteries provided as part of the standard generator set.
- F. Batteries: Batteries (12V or 24 V) based on the charging and starting systems shall be provided. Batteries shall be easily accessible for maintenance and replacement and be installed in a corrosion resistant (fiberglass or plastic) battery tray.
- G. Cooling System: The cooling system shall incorporate an engine driven fan, enclosure mounted radiator and ethylene glycol based coolant. Access to the radiator cap shall allow for filling of coolant without the need for additional funnels, piping, etc.
- H. Enclosure: The enclosure shall be sound attenuating (78 dB(A) at 7 meters), weather proof, aluminum and wind rated for min. 165 MPH (or current PBC requirement). The enclosure shall be coated with manufacturers standard coating system and color.

Sound attenuating material shall be moisture and weather resistant, securely fastened to the enclosure interior and protected from damage during routine maintenance and operation.

The enclosure shall house the generator muffler and all generator appurtenances (controller, radiator, breaker, etc.) except the fuel tank.

All hinges, latches and locks shall be corrosion resistant stainless steel.

- I. Controller: The generator controller shall provide/display the following functions.
  - a. Programmable generator exercise schedule.
  - b. Cool down period prior to shutoff.
  - c. All phase AC voltage
  - d. Current output
  - e. Each phase AC voltage
  - f. Utility status
  - g. KW power output
  - h. Power factor
  - i. Total runtime
  - j. Last runtime
  - k. Engine Speed
  - l. Overcrank
  - m. Oil Pressure
  - n. Fuel Pressure
  - o. Water Temperature
  - p. Coolant Level
  - q. Battery Voltage



- r. Frequency
  - s. Off/On/Auto(Remote)
  - t. Alarms
    - i. Oil Pressure
    - ii. Coolant Temperature
    - iii. Coolant Level
    - iv. Low Fuel Pressure
    - v. Engine Speed
    - vi. Overcrank
    - vii. Battery Voltage
- J. Generator Main Circuit Breaker: The generator set shall be provided with a generator main breaker mounted and wired on the generator set. The main breaker shall be UL listed, 480/277 VAC, 200 ampere and configured such that load side cables enter through the bottom of the enclosure.
- K. Air Filter: The generator set shall be provided with a dry type replaceable air filter.
- L. Mounts: Mounts for the generator set to the frame shall be spring type vibration isolation mounts.
- M. Exhaust Silencer: The exhaust silencer shall limit exhaust noise to 78 dB(A) at 7 meters. All enclosure interior exhaust piping shall be insulated to maintain a surface temperature not to exceed 150 degrees F. The insulation shall be installed so that it does not interfere with other components. The insulation shall not be asbestos base.

162.07      Automatic Transfer Switch

The automatic transfer switch shall be UL listed, electrically operated, 480/277 VAC, 3 phase, 60 Hz, 200 ampere and incorporate a mechanical lockout for only normal or emergency power. The use of molded case circuit breakers, contactors or components that are not intended for continuous duty, repetitive switching and transfer service will not be allowed.

The switch shall be mounted in a NEMA-4XSS enclosure.

The switch shall provide the following functions:

- A. Phase voltage sensing and transfer of power based on voltage of primary or emergency source. Transfer limits shall be adjustable for pick-up (85%-100% of nominal voltage) or drop-out (75%- 98% of pickup).
- B. Three phase voltage sensing and transfer of power based on voltage of primary or emergency source. Transfer limits shall be adjustable for pick-up (85%-100% of nominal voltage) or drop-out (fixed at 84%086% of pickup).
- C. Three phase frequency sensing and transfer of power based on frequency of primary or emergency source. Transfer limits shall be adjustable for pick-up (90%-100%) and drop out (fixed at 87%-89% of pickup).
- D. Time delay start in accordance with NFPA 110, Level 1, Type 10 (10 seconds).

- E. Time delay transfer to emergency power after start. Transfer time shall be adjustable from 0-120 seconds.
- F. Time delay transfer to primary power. Transfer time shall be adjustable from 0-30 minutes.
- G. Time delay shutdown of emergency generator after transfer to primary power. Transfer time shall be adjustable from 0-15 minutes.
- H. Status display:
  - a. Primary Power Status
  - b. Emergency Power Status
  - c. Current Power Source
  - d. Time to transfer (in consideration of time delays) to/from emergency
  - e. Transfer complete to/from emergency
  - f. Time to emergency generator stop

162.08        Testing

The generator set shall have factory production testing completed at the rated load. The production testing shall incorporate all parameters and limits identified in this specification. A factory certified record of testing shall be provided in the submittal.

After installation the manufacturer shall provide start up and testing services. Services shall conform to NFPA 110 and include start and shut down cycles, automatic start and load bank test at full load for 2 hours, power transfer and operation of the station on emergency power for not less than 2 additional hours.

162.09        Start-up and Instructions

On completion of the installation, start-up shall be performed by the generator set service representative. Operating and maintenance instruction manuals shall be supplied and operator training provided to operating personnel (minimum 2 hours training). Upon completion a start-up report shall be provided.

**END OF SECTION 162**

## **SECTION 168**

### **INSTRUMENTATION**

#### 168.01      General

Instrumentation as described in this specification and shown in the drawings shall be provided.

Instrumentation shall be incorporated into the design requirements of the Contractor utilizing the equipment and materials included in this specification.

All electrical components of the system shall operate on 120 volt, single-phase, 60 hertz or 24 VDC power, except as otherwise noted in the specifications.

All electrical components located within the wetwell and the wetwell side of any sealed conduit fitting shall be Intrinsically Safe.

All necessary fuses or switches required by the instrumentation manufacturer for his equipment shall be provided with the equipment.

#### 168.02      Submittals

Detailed design drawings including product specification sheets, mounting hardware, location, conduit, cable and tag numbers shall be provided.

#### 168.03      Cable

All electronic (4-20MADC) signal wire shall be two conductors, copper, twisted pair with tape foil shield and drain wire. The shield is to be grounded at the PLC I/O panel only for single point grounding, in accordance with manufacturer's instructions. Single triad shielded cables for potentiometer signal cables shall be three conductors, copper, twisted triad with tape foil shield and drain wire. The cables must be UL listed for wet locations as defined by the NEC.

#### 168.04      Instrument Mounts

All instruments shall be mounted in readily accessible positions that do not require entry into the wetwell for removal or maintenance. Brackets shall be fabricated to hold instruments. All brackets shall be 304 or 316 stainless steel. All mounting hardware, screws, machine bolts with washers and nuts shall be 316 stainless steel.

#### 168.05      Conduits

All low voltage signals shall be isolated from high level control or power signals in separate conduits. All instrumentation signal conduits below grade shall be SCH80 PVC or 304 stainless steel. All underground conduits shall have grounding bushings and a No. 8 AWG copper minimum cable run to a ground lug at the termination points.

#### 168.06      Lightning/Surge Protection

All transmitters with 4-20 MADC outputs shall have a transmitter mounted surge protection unit. The surge protection unit shall be a EDCO SS65 or approved equal.

168.07        Intrinsically Safe Pressure Transducer

Pressure transducers shall be intrinsically safe and encased in a 316 stainless steel housing.

1.     Range: 0 – 15 PSI
2.     Cable: Minimum 50'
3.     Output: 4 – 20 mA
4.     Accuracy: +/-5%

Pressure transducers shall be Blue Ribbon Model 311Z or approved equal.

168.08        Intrinsically Safe Pressure Transmitter

Pressure transmitters shall be intrinsically safe, backlit and mounted in the power and control panel dead-front.

1.     Display: 5 Digit
2.     Input: 24 VDC
3.     Output: 4 – 20 mA
4.     Accuracy: +/- 0.03%

Pressure transmitters shall be Precision Digital model 688 or approved equal.

168.09        Power Supplies

All instruments shall be looped powered with an appropriately rated power supply. Each instrument shall have a dedicated power supply.

168.10        Field Calibration and Testing

All instruments shall be set up, calibrated and tested in the field. The Contractor shall provide calibration sheets and testing equipment for each instrument. When installation is complete all components shall be tested to confirm operation and compliance with the contract.

168.11        Installation

All equipment shall be installed per the manufacturers requirements.

**END OF SECTION 168**

## SECTION 169

### PROGRAMMABLE LOGIC CONTROLLERS

#### 169.01 General

This section describes the hardware and software requirements for a new Programmable Logic Controller (PLC) for a duplex or tri-plex lift submersible wastewater lift station with adjustable frequency drives, level control, emergency standby power, DFS radio telemetry unit (or) Cellular telemetry unit and appurtenances.

This section provides all labor and material required for the PLC system including the panels, equipment, software, screen development, programming, conduit, cable, tie-ins, checkout and start-up of the complete integrated system. This section shall be used in conjunction with the approved drawings and Section 161, Variable Speed/PLC Control Panels.

The latest version available at the time of installation of all PLC development software and communication driver software shall be provided.

All software and programming shall be required to perform the following functions in addition to the interlocking, monitoring and control functions indicated on the loop diagram drawings and developed in the PLC logic and OWS screen development meetings.

All enclosures shall be UL listed and NEMA rated to house the PLC, remote I/O, power supplies, and terminal blocks as shown in the drawings.

All panels shall be UL listed and labeled as a completed assembly. The panel fabricator shall furnish and install all items not specifically detailed in the drawings required to have the panels UL listed and labeled. All inspections, approvals and modifications required to have the completed panel labeled and listed by UL shall be furnished by, and the responsibility of the panel fabricator.

#### 169.02 Applicable Standards

NEC  
NEMA  
UL  
IEC

Temperature	IEC60068:
Relative Humidity	IEC60068:
Vibration	IEC 60068
Shock	IEC 60068
Emissions	IEC61000
ESD Immunity	IEC 61000
Radiated RF Immunity	IEC61000

EFT/B Immunity	IEC61000
Surge Immunity	IEC61000
Conducted RF Immunity	IEC61000

169.03      Operation and Maintenance Manuals

All products shall be provided with operation and maintenance manuals complete with installation, troubleshooting and technical information on the equipment provided under this contract. Manuals shall be published by the equipment manufacturer.

169.04      Training

Training and instruction shall be given by the manufacturer or representative. Training shall be 4-hours for personnel selected by the Owner in the operation and general maintenance of the PLC. This training is independent of operator training for lift station observation and operation associated with automated controls.

169.05      Submittals

Submittals shall include installation drawings and manufacturer cutsheets clearly defining the products to be provided, their accessories/options and interconnectivity with all systems. Drawings shall also include single line system diagrams and detailed line diagrams for power, input/output and tag numbers.

169.06      Spare Parts

- A. One CPU
- B. One of each Network Module
- C. One of each type of input/output and data link module
- D. One of each type of power supply

169.07      Programmable Logic Controller

1. Approved Manufacturer

The PLC system shall be a Rockwell Automation 1756 ControlLogix L7\*\*\*\* .

2. General

The PLC system (memory, communications, input/output modules, processor, power supplies, software) shall be a modular chassis mounted system and come complete from one manufacturer to provide a complete functioning control system as depicted in the Control Block Diagram and described in the operating protocol and of sufficient capacity for future expansion as allowed for in this specification.

Products shall be provided with conformal coatings, factory applied, to extend product life in harsh, corrosive environments.

The PLC shall be programmable and configurable from a Windows 7 and Windows 10

3. Communication

The PLC system shall be Ethernet compatible or have an Ethernet module accessible by a laptop computer. Programming functions associated with the PLC system shall be accessible through the Ethernet connection.

The PLC shall have a compatible communication modules or ports for communicating with the emergency standby generator controller exclusive of input/output modules and dry contacts. This communication port shall allow for sharing of all monitoring and alarm data associated with the emergency generator controller.

4. Input/Output Modules

The PLC shall have analog and discrete input/output modules sufficient for all proposed and future nodes identified in the control block diagram associated with the DFS Radio Telemetry System.

The PLC shall have analog and discrete input/output modules sufficient for all proposed generator status and generator fail signals.

The PLC shall have analog and discrete input/output modules sufficient for all proposed ATS, commercial, generator power signals.

The PLC shall have analog and discrete input/output modules sufficient for variable speed pump control based on level. PLC control and monitoring of variable speed drives shall be through analog and discrete input/output modules. The use of proprietary communication protocols for variable speed drive control shall be allowed.

The PLC shall have the ability to accommodate 50% additional I/O modules.

5. Central Processing Unit

The PLC configuration shall be maintained through a power loss. The PLC shall continue with operations when power is reinstated without additional programming, uploads or resets.

The PLC system shall utilize a Secure Digital (SD) card for non-volatile memory to store a user program and tag data on the PLC. The PLC system shall be

configurable to trigger the controller to save to or load from the SD card and to load to the controller from the SD card on power up.

The minimum size CPU shall be an A-B Rockwell Automation ControlLogix Series 1756-L71 with 128 MBs of optional nonvolatile memory storage.

6. Power Supplies

Power supplies shall be surge and transient protected, and shall accept input voltages of 90 to 130 VAC. The power supplies shall be fused.

All PLC systems power supplies shall be modular, allowing the power supply to be removed for replacement without affecting input/output modules or wiring.

The PLC systems shall come with redundant power supply.

7. Wire and Cabling

All PLC specific cables shall be furnished by the PLC system manufacturer and be designed for the intended use.

All other wire shall be stranded copper type TFF or MTW, 18 GA for I/O and minimum 14 GA for power.

8. Programming

The CPU shall be capable of being programmed by an external IBM compatible host device via either a serial communication port or Ethernet port on the CPU, or a parallel communication port on an input/output chassis. Serial programming shall be possible without the use of a workstation interface board.

Software shall be Rockwell Automation RSLogix 5000 Professional Edition.

All software shall be registered to the Owner.

9. Terminal Blocks

Input/output modules shall utilize removable terminal blocks to connect all field side wiring.

10. Signal Isolators, Converters and Conditioners

Instrument signals shall be 4 – 20 mA DC. Signal isolators and converters shall be provided as necessary to comply with this requirement. The devices shall be mounted in the panel and such that field wiring may be changed/maintained without affecting the devices.



All communication circuitry shall include protection against lightning, spikes and other transient surges.

11. Grounding

The grounding system of the PLC system shall be tied into the main ground system. The tie-in shall be made from the panel frames to the main ground system.

169.08 Execution

Start-up and testing services for the PLC system shall be provided. The PLC system shall be fully tested against the requirements outlined in this section and Section 161 and the operating protocol and equipment manufacturer requirements. Test procedures and checklists for approval shall be submitted prior to testing. Completed test checklists shall be submitted as part of the project record documentation.

**END OF SECTION 169**

## SECTION 170

### REMOTE TERMINAL UNIT (RTU) – LIFT STATION

#### 170.01 General

The District has an existing Radio Telemetry System as manufactured by Data Flow Systems, Melbourne, Florida (321) 259-5009. For compatibility purposes, new remote terminal units will be required as specified herein from Data Flow Systems (DFS) 321-259-5009. The remote terminal unit shall include all materials, labor, tools, equipment, and appurtenances necessary for the proper completion of the work. The work covered by these specifications consists of providing all design, labor, tools, materials, and testing necessary for the supply of the RTU as described herein.

Physical location information shall be provided to DFS for radio communication study purposes. Information shall be provided in the form of GPS readings or street map with actual site location(s) clearly marked.

The RTU shall be housed in its own enclosure. The RTU enclosure shall be mounted on the antenna tower. The RTU shall be powered by 120 VAC commercial power, monitor local statuses and transmit those statuses to the existing central site when polled by the master radio. An Uninterruptible Power Source (UPS) shall be included with the RTU.

#### 170.02 Equipment Specification

##### 170.02.1 Remote Terminal Unit (RTU204)

The remote terminal unit shall be DFS Model RTU204. The RTU shall communicate with the central site via a two-way radio link and designed to accommodate the required plug-in function modules. Function module card connectors shall be gold-over-nickel plated to inhibit corrosion. The RTU shall be housed in a white color NEMA 4X 316 SS enclosure. All mounting hardware utilized shall be stainless steel. The enclosure shall be capable of being locked. The latches utilized to secure the door of each enclosure shall not require the use of a screwdriver to open or close.

##### 170.02.2 Power Supply Module (PSM003)

The RTU shall include a Power Supply Module (PSM003). All function modules in the RTU shall run off DC voltage from +7.5 volts to +13 volts. The PSM shall supply +12 volts. A battery backup shall be provided in event of power failure. The power supply shall be surge protected. The power supply shall be short circuit protected by current limiting. Normal operation shall automatically resume when the short circuit overload is removed. The power supply shall be sized to operate the system with the battery removed. The power supply module shall provide a battery backed, isolated bias voltage source. The circuit breaker for the power supply module shall be part of the power supply module. Neither the use of tools nor the disconnection of any wires shall be required to replace the power supply module.

### 170.02.3 Backup Battery/Uninterruptable Power Supply (UPS)

The RTU shall have the uninterruptible power supply (UPS) function built in. The RTU's internal Power Supply Module shall keep the battery at a float charge. The battery shall not be damaged by deep discharges.

### 170.02.4 Telemetry Interface Module (TIM007)

- a) The Telemetry Interface Module (TIM) shall incorporate a synthesized programmable radio.
- b) A data buffer on the TIM shall enable it to query and store the I/O function module(s) status between radio polling loops until data is requested by the central site.
- c) The TIM shall feature a wake up/report/sleep mode to aid in battery conservation for solar-powered applications.
- d) The TIM shall support four levels of digipeating (store and forward), enabling radio messages from a different RTU to be routed to the central site.
- e) The TIM shall monitor AC power on the Power Supply Module and DC Bias to the RTU I/O function modules.
- f) The TIM shall incorporate a 2x8 character LCD display and 3-button user interface for field diagnostics and support data without the use of a portable computer.
- g) The TIM shall incorporate a test mode switch that places the radio into a service mode.
- h) The TIM shall incorporate LEDs for TX, RX, Power, CPU Fault.

### 170.02.5 Digital Monitor Module (DMM002)

The RTU shall include a Digital Monitor Module (DMM002). The DMM002 shall accept 12 on/off inputs of 12 to 30 volts AC or DC. Voltages from 100 to 300 volts AC or DC shall be accommodated with the use of an inline voltage converter device. Status reporting of these inputs shall have an accuracy of +/- 2 seconds, the accuracy being defined as time of an occurrence to actual time recorded by the central site computer. The DMM002 shall not require interfacing relays to monitor 24 VDC, 115 VAC, 220 VAC or 480 VAC. The DMM002 shall have LEDs to indicate: the status of each input point; receive communications; transmit communications; CPU fault; and power status. The configuration of the monitor points as alarm points or monitor points (pump run time monitors) shall be operator changeable. The configuration shall not require any software or firmware changes in the system.

### 170.02.6 Antenna Subsystem

DFS shall determine the antenna type and height required for reliable communications. A high gain directional or omni antenna shall be used to transmit and receive data. The antenna mast/pole shall be hot dipped galvanized for corrosion protection. All mounting hardware shall be made of stainless steel. The coax cable shall be the type that utilizes an inert semi-liquid compound to flood the copper braid. The coax cable shall be of the RG-8 construction type and have the RF-loss characteristic of foam flex. The coax cable shall be RTC 400 as supplied by DFS. Type N connectors shall be utilized at both ends of the coax and sealed with 3-inch sections of Alpha

FIT321-1-0 sealant shrink tubing. The coax cable shall be secured to the mast/pole with AE112 Bandit coated 316 stainless steel cable ties. The RTU shall be protected from electrical surge or transients entering through the coaxial cable by use of a IS-B50LN-C2 Polyphaser coaxial cable surge protector.

170.02.7 RTU Monitor Points

The RTU shall accommodate the following I/O points.

**RTU HARDWIRED I/O LIST:**

DIGITAL INPUT (DI)	DIGITAL OUTPUT (DO)	ANALOG INPUT (AI)	ANALOG OUTPUT (AO)
COMMERCIAL POWER	PUMP 1 OVERRIDE	WET WELL LEVEL	NONE
AUXILIARY POWER	PUMP 2 OVERRIDE	(3) AI SPARE	
HIGH WET WELL LEVEL	*PUMP 3 OVERRIDE		
PUMP 1 RUN STATUS	PUMP 1 DISABLE		
PUMP 2 RUN STATUS	PUMP 2 DISABLE		
*PUMP 3 RUN STATUS	*PUMP 3 DISABLE		
PUMP 1 FAULT	(2) DO SPARE		
PUMP 2 FAULT			
* PUMP 3 FAULT			
GENERATOR GENERAL ALARM			
GENERATOR LOW COLLANT			
GENERATOR LOW FUEL			
GENERATOR FAIL TO START			
(7) DI SPARE			
* If applicable			

170.03 Installation

In order to insure total system integration with the existing system, secure and provide the services of Data Flow Systems, Inc. for RTU hardware.

170.04        Programming

Antenna alignment fine-tuning procedure, configuration of RTU into the system, RTU point-by-point verification at the central computer, and RTU screen generation services shall be covered by the District.

170.05        Warranty

DFS shall warrant all hardware provided under this contract against all defects in material and workmanship for a period of one year. The RTU plug-in modules shall carry an additional 2-year return-to-manufacturer warranty and shall be covered against damage due to lightning and surge the entire 3-year period.

170.06        Spare Parts

Provide the following spare parts with the RTU:

- a.        (1) Telemetry Interface Module (TIM007)
- b.        (1) Power Supply Module (PSM003)
- c.        (1) Digital Control Module (DCM003)
- d.        (1) Digital Control Module (DCM004)
- e.        (1) Analog Monitor Module (AMM ---)
- f.        (1) Backup Battery
- g.        (1) RTU Antenna

**END OF SECTION 170**

- LP LOW PRESSURE FORCE MAIN DETAILS INDEX
- LP-1 TYPICAL RESIDENTIAL GRINDER SYSTEM LAYOUT (PLAN VIEW)
- LP-2 TYPICAL RESIDENTIAL GRINDER SYSTEM LAYOUT (SECTION VIEW)
- LP-3 ALTERNATE RESIDENTIAL GRINDER SYSTEM LAYOUT (PLAN VIEW)
- LP-4 ALTERNATE RESIDENTIAL GRINDER SYSTEM LAYOUT FREE STANDING (1 OF 2)
- LP-5 ALTERNATE RESIDENTIAL GRINDER SYSTEM LAYOUT FREE STANDING (2 OF 2)
- LP-6 RESIDENTIAL SIMPLEX TYPICAL WET WELL
- LP-7 RESIDENTIAL SIMPLEX CONTROL PANEL LAYOUT
- LP-8 RESIDENTIAL SIMPLEX ELECTRICAL SCHEMATIC
- LP-9 RESIDENTIAL DUPLEX TYPICAL WET WELL
- LP-10 RESIDENTIAL DUPLEX CONTROL PANEL LAYOUT
- LP-11 RESIDENTIAL DUPLEX ELECTRICAL SCHEMATIC
- LP-12 COMMERCIAL DUPLEX TYPICAL WET WELL
- LP-12 ALT COMMERCIAL DUPLEX TYPICAL LOW FLOW WET WELL
- LP-13 COMMERCIAL DUPLEX CONTROL PANEL SUPPORT
- LP-14 COMMERCIAL DUPLEX CONTROL PANEL DEADFRONT LAYOUT
- LP-15 COMMERCIAL DUPLEX CONTROL PANEL BACKPLATE LAYOUT
- LP-16 COMMERCIAL DUPLEX CONTROL PANEL BILL OF MATERIALS
- LP-17 COMMERCIAL DUPLEX ELECTRICAL SCHEMATIC 1PHASE
- LP-18 COMMERCIAL DUPLEX ELECTRICAL SCHEMATIC 3PHASE
- LP-19 COMMERCIAL DUPLEX ELECTRICAL SCHEMATIC CONTROL CIRCUIT
- LP-20 COMMERCIAL DUPLEX ELECTRICAL SCHEMATIC NOTES
- LP-21 PIPE CONNECTION DETAIL
- LP-22 TYPICAL SINGLE SERVICE SCHEMATIC
- LP-23 TYPICAL DOUBLE SERVICE SCHEMATIC
- LP-24 TERMINAL FLUSHING PORT DETAIL
- LP-25 IN LINE FLUSHING PORT
- LP-25A IN LINE FLUSHING PORT AT FORCE MAIN
- LP-26 AIR / VACUUM VALVE DETAIL
- LP-27 LOW PRESSURE MAIN INTO SHALLOW MANHOLE
- LP-28 LOW PRESSURE MAIN INTO DEEP MANHOLE
- LP-29 TYPICAL ISOLATION VALVE DETAIL
- LP-30 LOW PRESSURE TIE - IN DETAIL
- LP-31 LOW PRESSURE VALVE DETAIL
- LP-32 TYPICAL ROAD CROSSING REPAIR DETAIL
- LP-33 TRENCH DETAIL
- LP-34 TESTING PROCEDURE
- LP-35 GENERAL NOTES

**LOXAHATCHEE RIVER DISTRICT**

REVISION:  
REVISION:  
MARCH, 2017

**LOW PRESSURE FORCE MAIN DETAILS INDEX**

**LP**

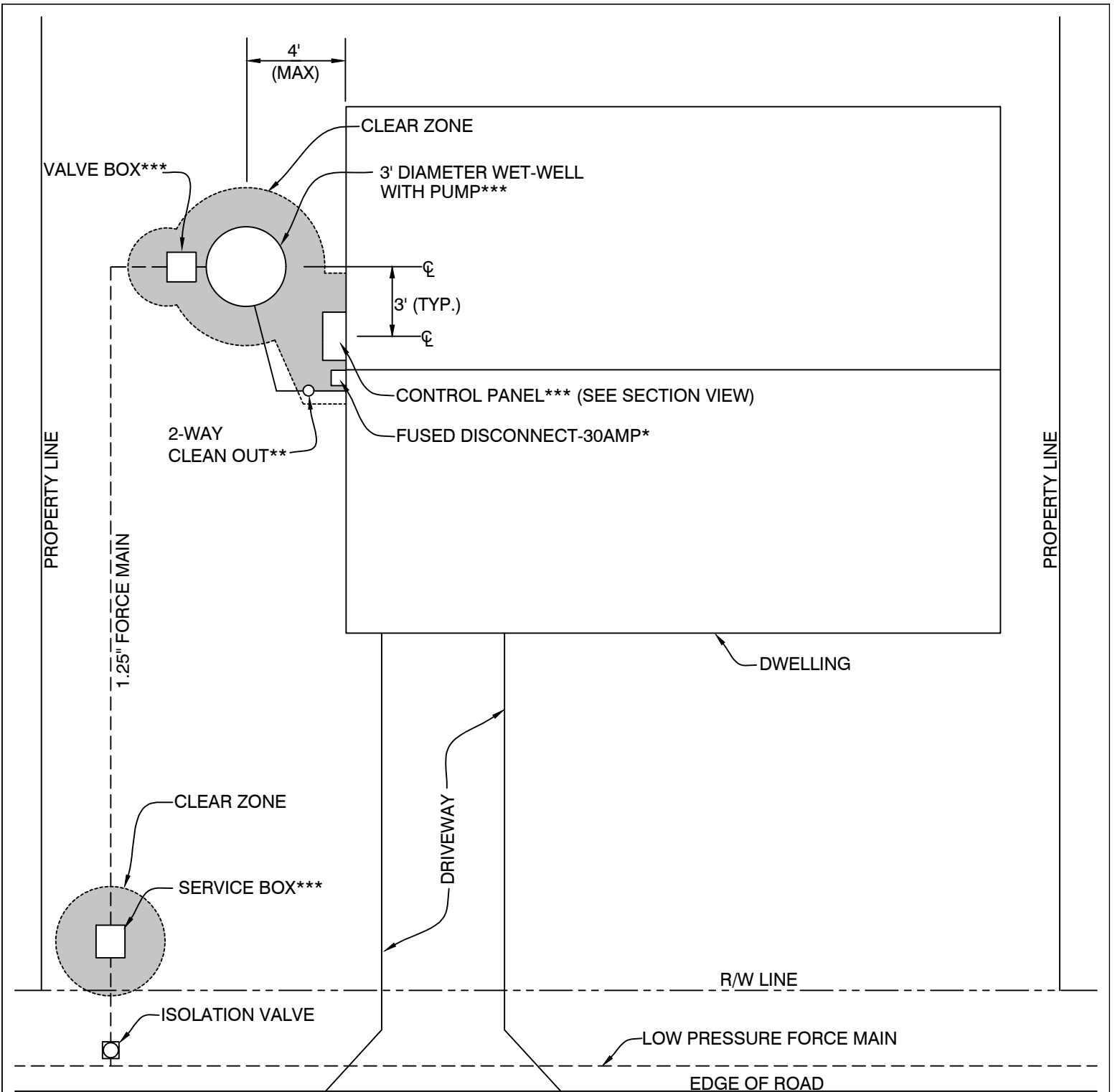

\*FOR DUPLEX INSTALLATIONS (5,000 sq ft or more) USE 60 AMP FUSEABLE DISCONNECT.

\*\*REPLACE EXISTING CLEANOUT IF NOT 2-WAY.

\*\*\* PROVIDE A 36" CLEAR ZONE FREE FROM FENCING, LANDSCAPING AND OTHER OBSTRUCTIONS THAT MAY LIMIT ACCESS.

LOXAHATCHEE RIVER DISTRICT

TYPICAL RESIDENTIAL GRINDER SYSTEM LAYOUT (PLAN VIEW)

LP-1

N.T.S.

REVISION:  
JUNE, 2018

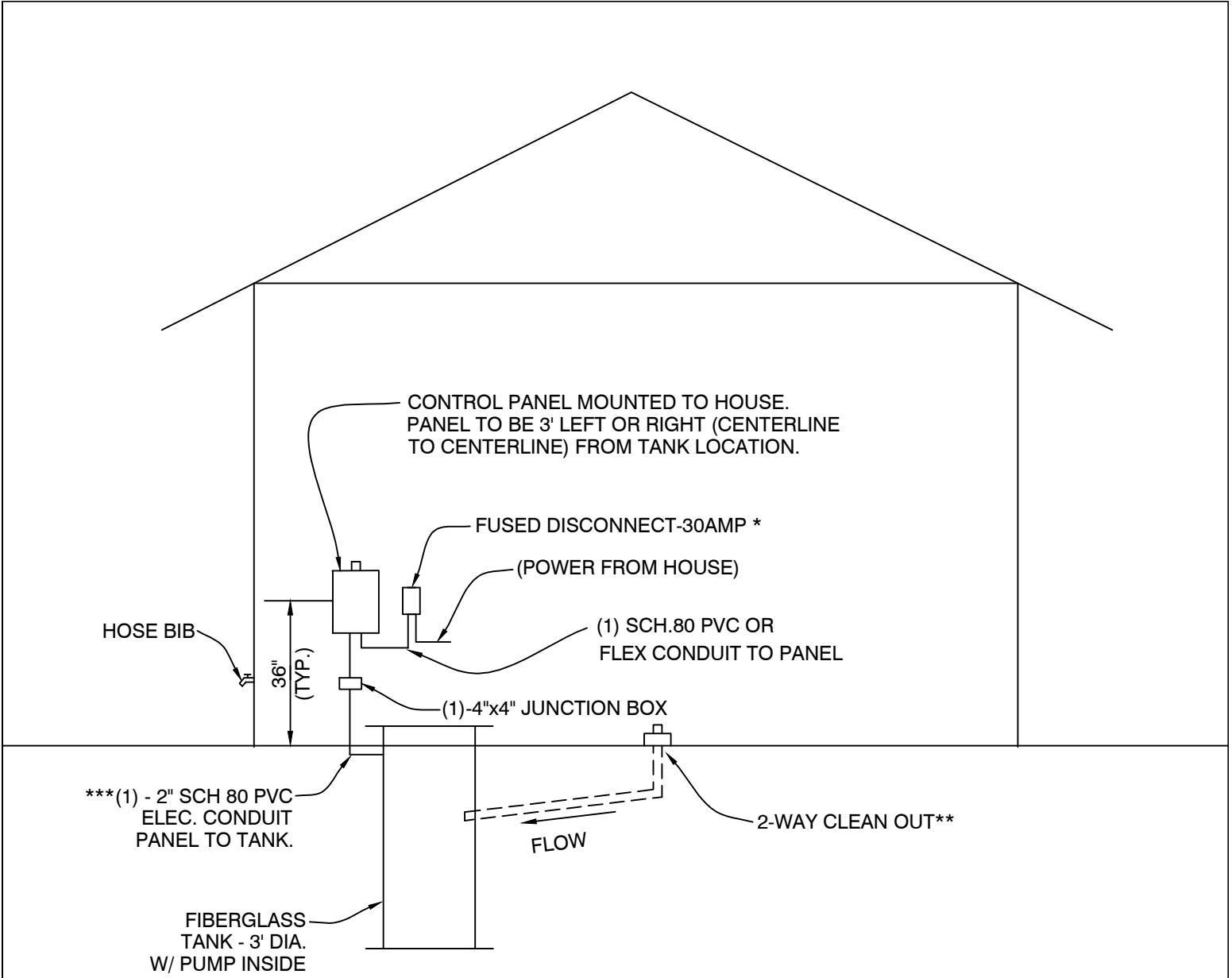

\*FOR DUPLEX INSTALLATIONS (5,000 sq ft or more)  
USE 60 AMP FUSEABLE DISCONNECT.

\*\*REPLACE EXISTING CLEANOUT IF NOT 2-WAY.

\*\*\*FOR DUPLEX STATIONS, USE TWO (2) - 2" SCH. 80 CONDUITS

LOXAHATCHEE RIVER DISTRICT

TYPICAL RESIDENTIAL  
GRINDER SYSTEM LAYOUT (SECTION VIEW)

LP-2

N.T.S.  
REVISION:  
APRIL, 2012



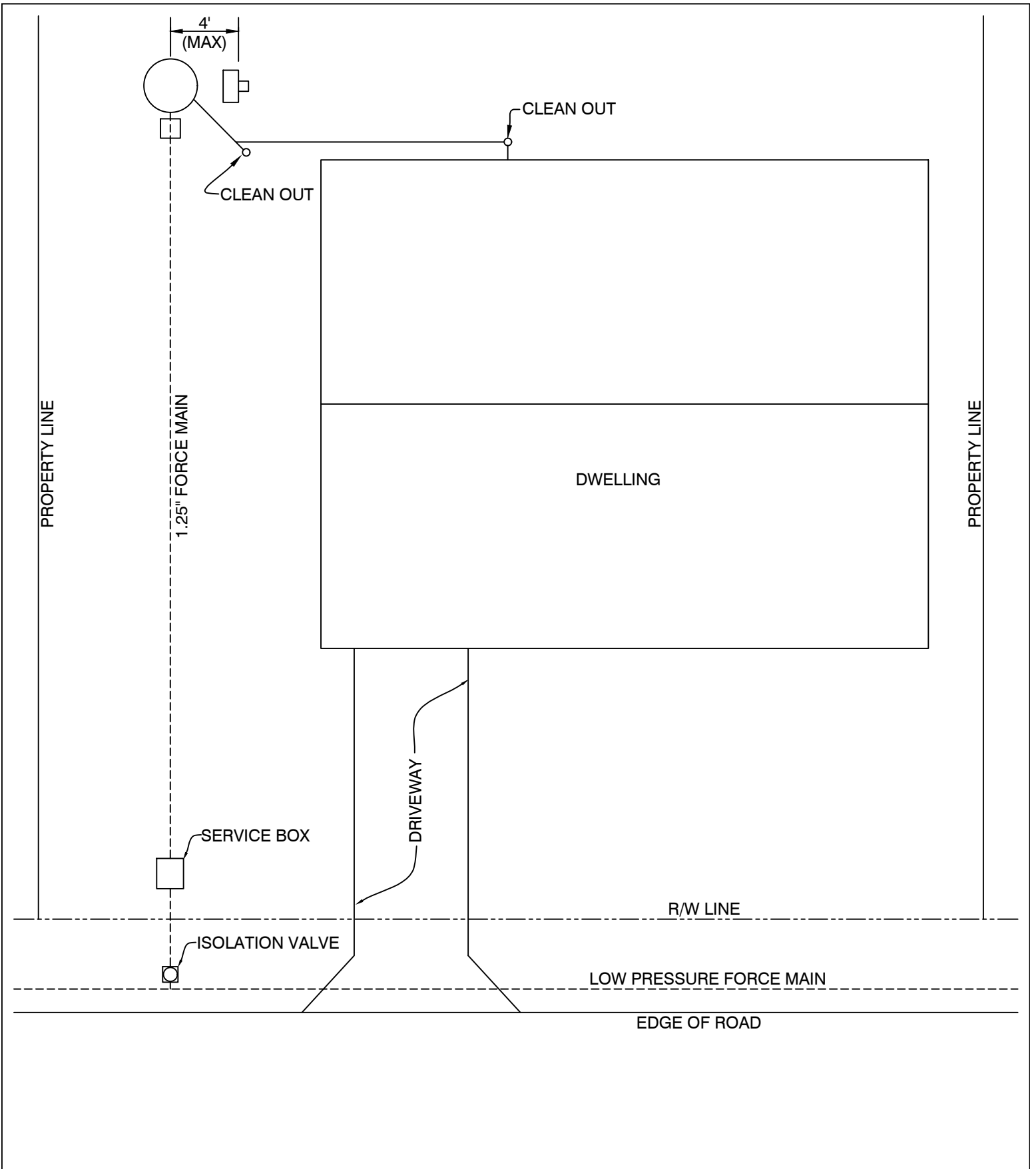

LOXAHATCHEE RIVER DISTRICT

ALTERNATE RESIDENTIAL  
GRINDER SYSTEM LAYOUT (PLAN VIEW)

LP-3

N.T.S.

REVISION:  
APRIL, 2012

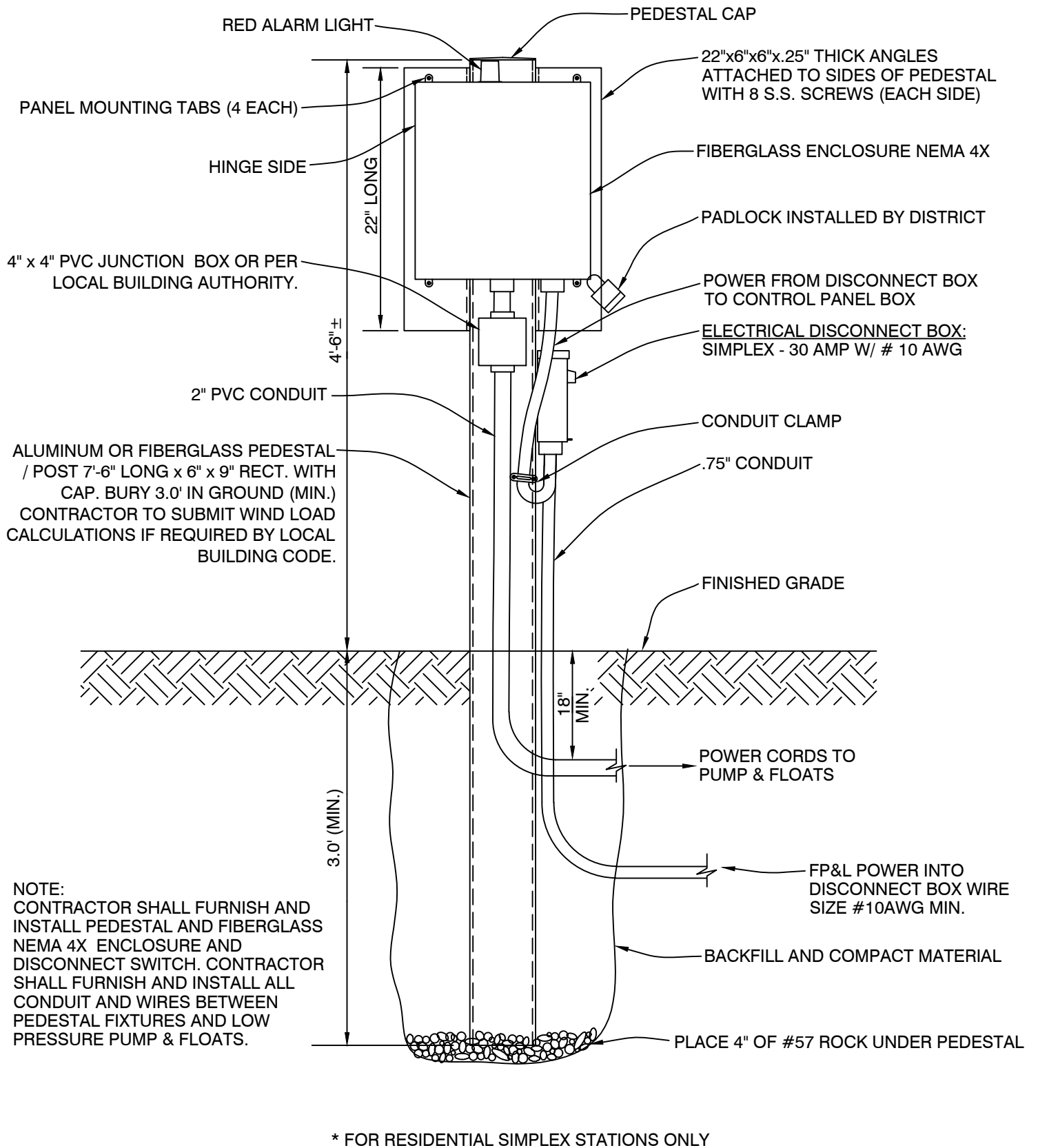

LOXAHATCHEE RIVER DISTRICT

ALTERNATE RESIDENTIAL GRINDER SYSTEM LAYOUT FREE STANDING (1 OF 2)

LP-4

N.T.S.

REVISION:  
MARCH, 2016

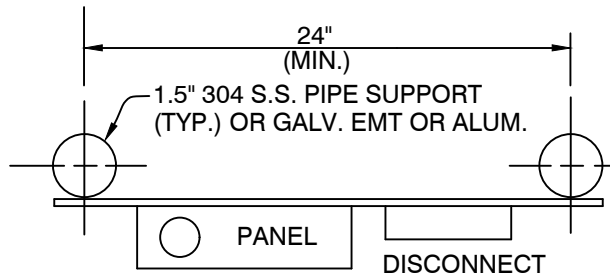

**PLAN VIEW**

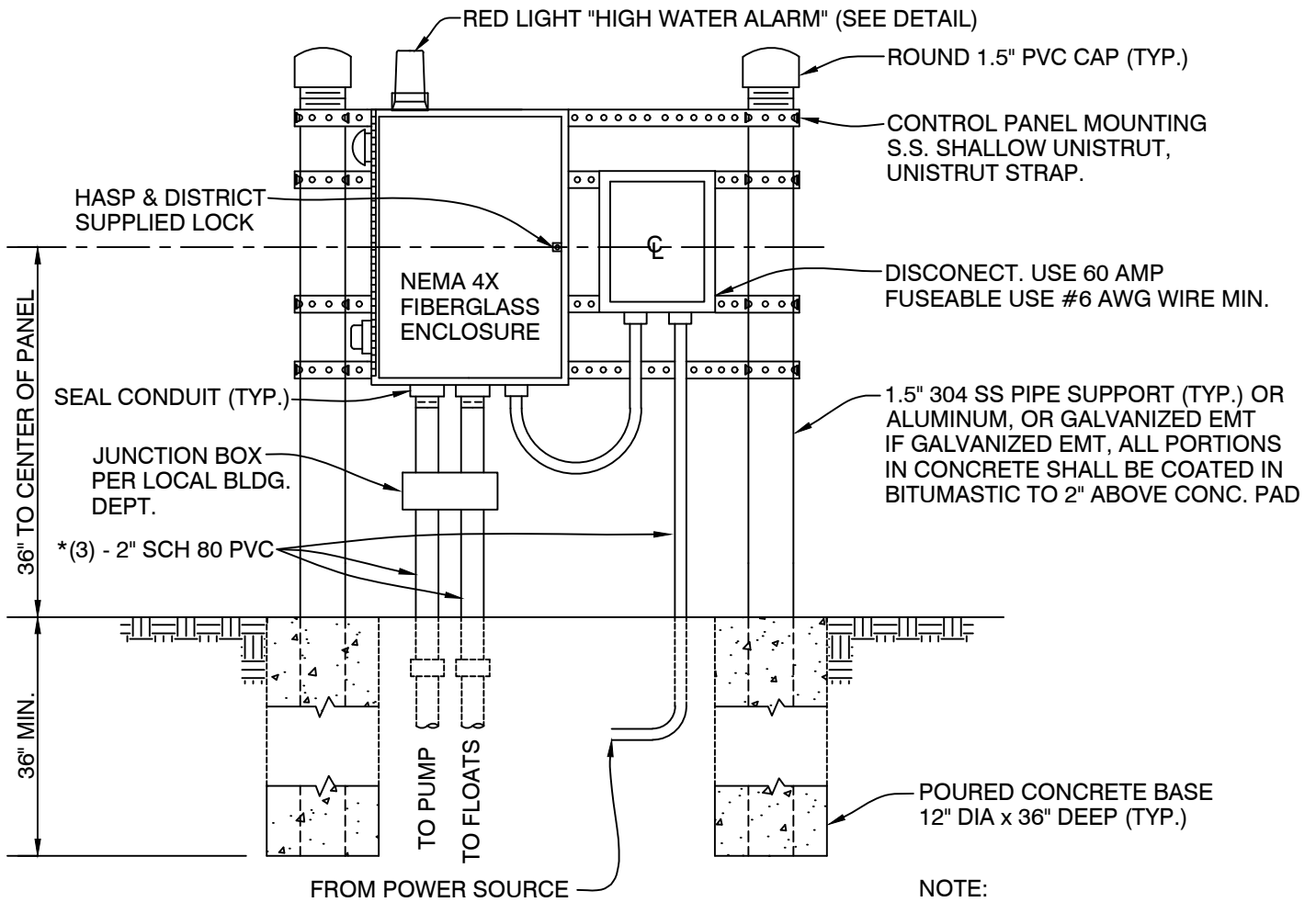

**FRONT ELEVATION**

\* FOR RESIDENTIAL DUPLEX STATIONS ONLY

**LOXAHATCHEE RIVER DISTRICT**

**ALTERNATE RESIDENTIAL  
GRINDER SYSTEM LAYOUT FREE STANDING (2 OF 2)**

**LP-5**

N.T.S.  
REVISION:  
APRIL, 2012

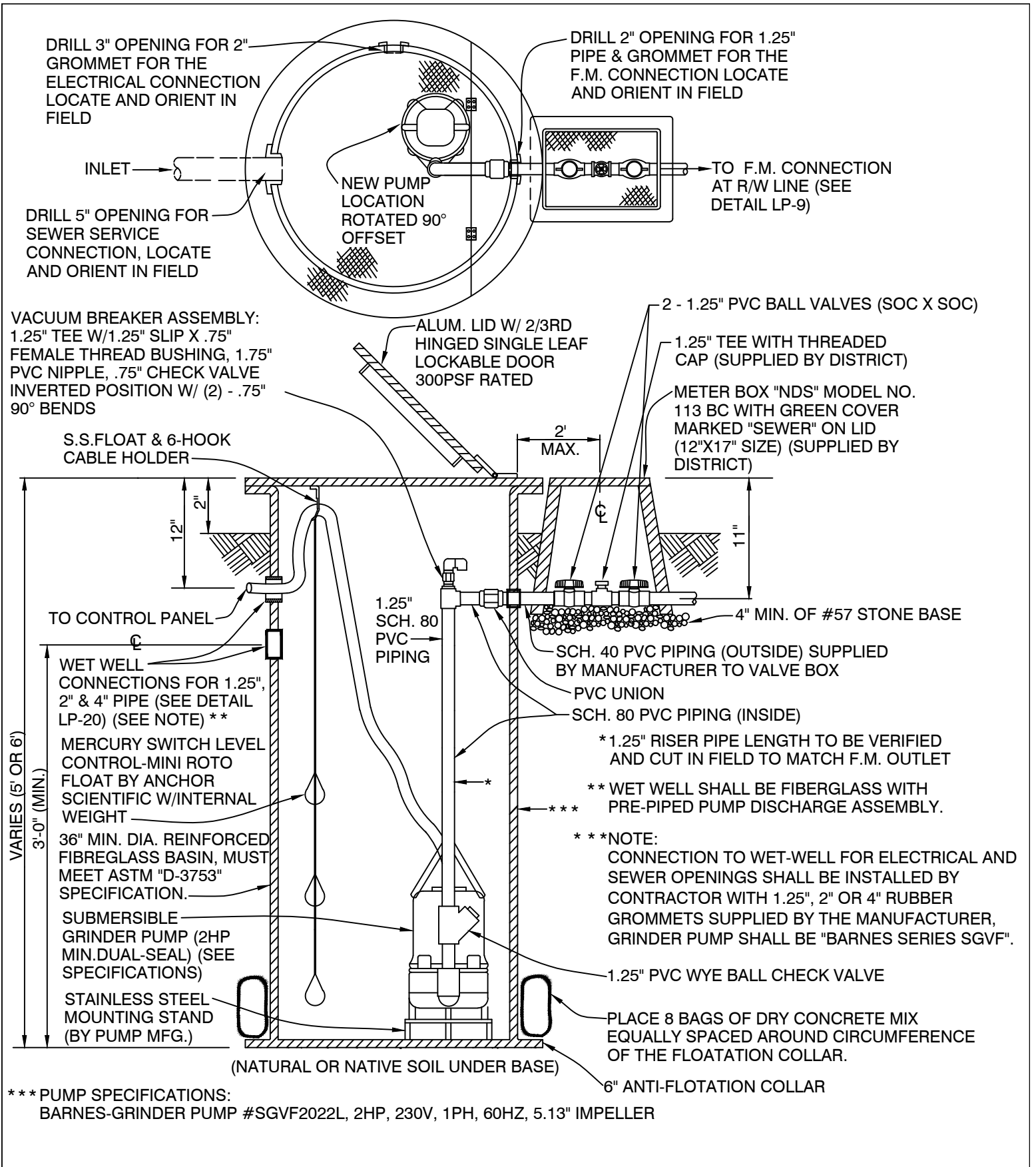

LOXAHATCHEE RIVER DISTRICT

RESIDENTIAL SIMPLEX  
TYPICAL WET WELL

LP-6

N.T.S.
REVISION: APRIL, 2012

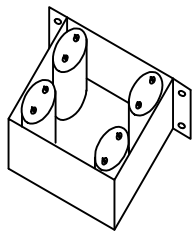
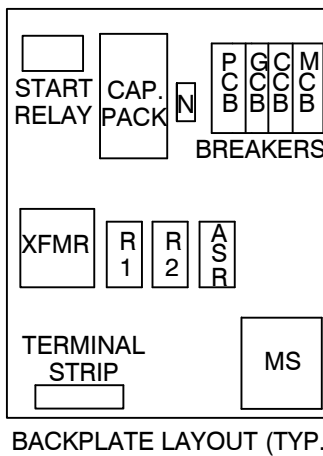
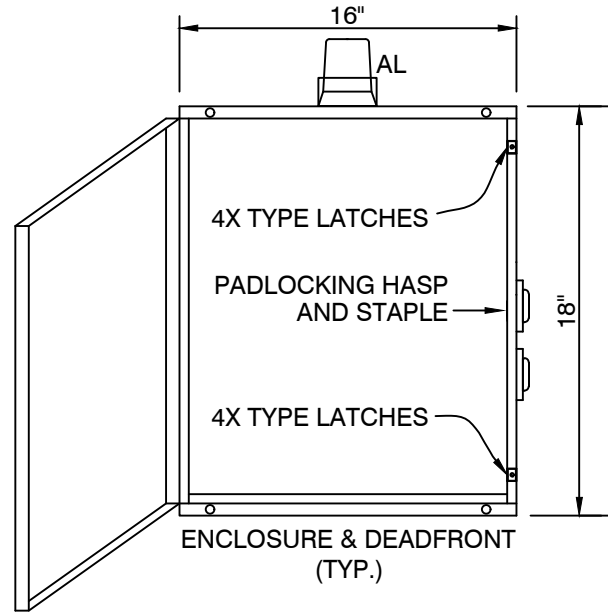
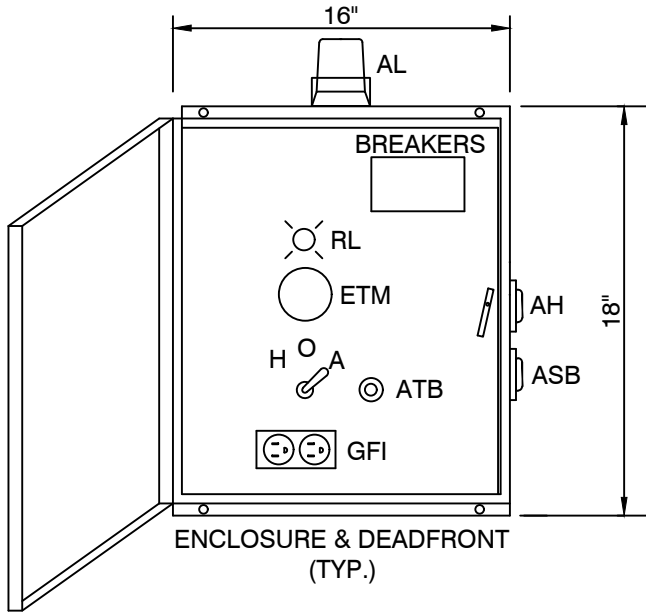

CAPACITOR  
PACK SUPPORT  
DETAIL

**BILL OF MATERIALS**

ENC	FIBERGLASS ENCLOSURE	ROBROY NEMA 4X, RJ1816HPL
PCB/MCB	PUMP & MAIN BREAKERS	SQ-D, QOU230
CCB/GCB	GFI & CONTROL BREAKERS	SQ-D, QOU115
MS	STARTER	SQ-D, 8502SBO2VO2S
OL	OVLD HTR ELEMENT	SQ-D, B25
XFMR	TRANSFORMER 50VA	SQ-D, 9070T50D13
ETM	ELAPSED TIME METER	CONTR. DYN. 120VAC, HMA303
HOA	HAND OFF AUTO SWITCH	MCGILL 20A, 910003
RL	RUN LIGHT	BACO 22M, L20SA50
AL	ALARM LIGHT	STONCO, VP11GCR
AH	ALARM HORN	FLOYD BELL, MC09201Q
*ASR	ALARM SILENCE RELAY	IDEC, SR3B05
ASB	ALARM SILENCE BUTTON	SQ-D, ZB4BA0
ATB	ALARM TEST BUTTON	SQ-D, ZB4BA2
GFI	15 AMP GFI RCPT	PASS SEYMOUR, 1595W
FU1	FUSE 1A	BUSS, MDL-1
FU2	FUSE 2A	BUSS, MDL-2
FU1-2	FUSE BLOCK	BUSS, BKS82021
OL	OVERLOAD RELAY	SQ-D, 9065SEO5
CR1-2	CONTROL RELAY	IDEC, RR2PULAC24V
CR1-2	8-PIN SOCKET	IDEC, SR2P06
TS	TERMINAL STRIP	ALTECH, TSF6012WP
CAP.PACK:		MARS RUN CAP OVAL 45MF/440V, 12448 MARS STRT CAP 250V 124-156MF, 11148 GE START RELAY, 16104
		TO MATCH GRINDER PUMP'S

\* OR APPROVED EQUAL

\* PANEL & COMPONENTS SHALL CONFORM TO INDUSTRIAL UL LISTING PRE SEC. 508 N.E.C.

LOXAHATCHEE RIVER DISTRICT

RESIDENTIAL SIMPLEX  
CONTROL PANEL LAYOUT

LP-7

N.T.S.

REVISION:  
APRIL, 2012

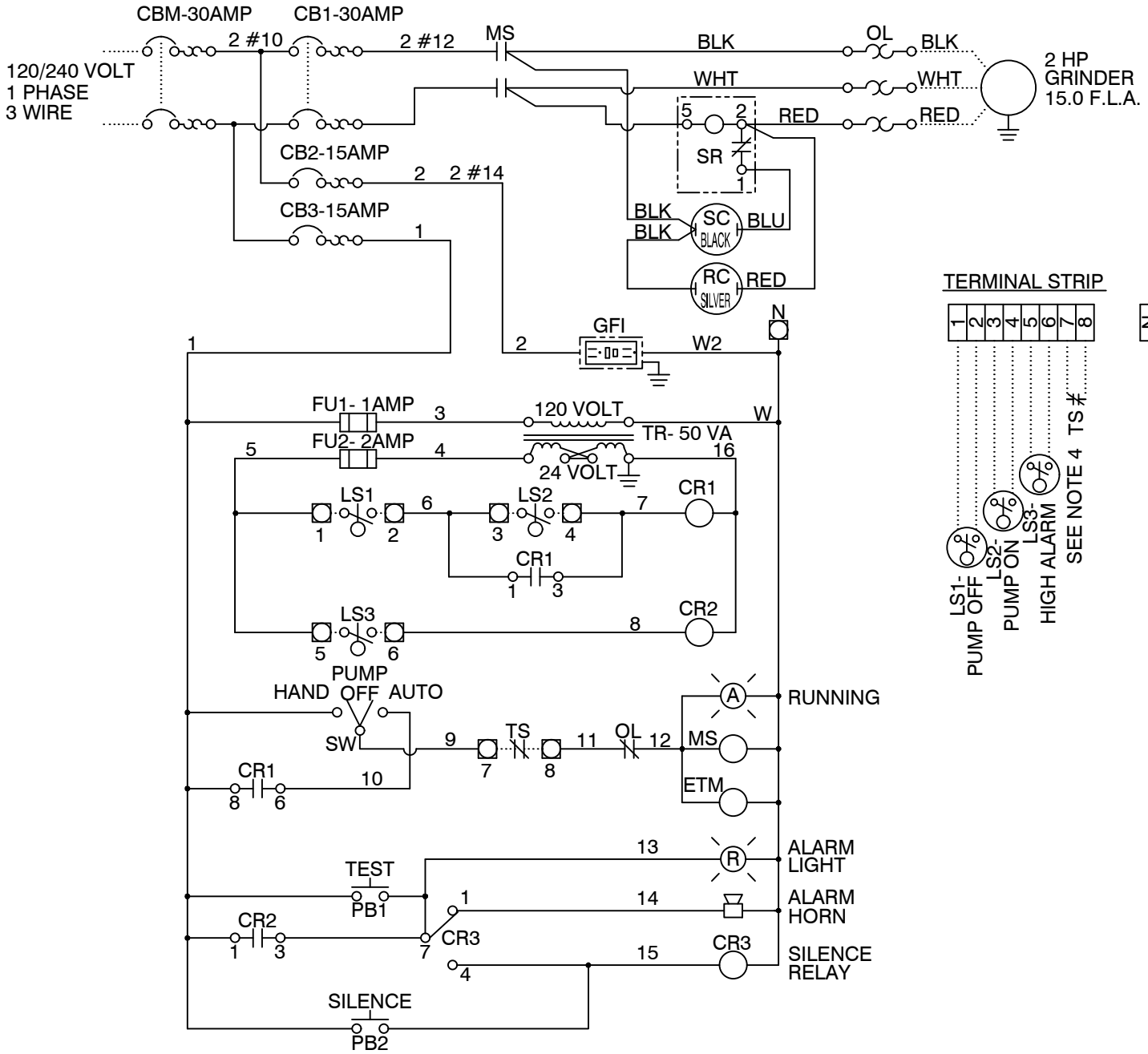

**TERMINAL STRIP**

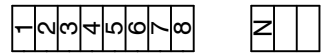

LS1- PUMP OFF  
 LS2- PUMP ON  
 LS3- HIGH ALARM  
 SEE NOTE 4 TS #

**NOTES:**

- 1.) PANEL GROUND TERMINAL MUST BE CONNECTED TO EARTH GROUND.
- 2.) FACTORY WIRING IS SHOWN \_\_\_\_\_  
FIELD WIRING IS SHOWN .....
- 3.) RECOMMENDED TIGHTENING TORQUES FOR TERMINALS 240 VOLT POWER 30 POUND INCHES. 120 VOLT POWER, CONTROL & LOW VOLTAGE - 20 POUND INCHES.
- 4.) THERMAL SAFETY SWITCH (TS) CONTACTS ARE NOT IN ALL MOTORS. IF MOTOR DOES NOT HAVE SWITCH, THESE TERMINALS MUST BE JUMPED.
- 5.) LAYOUT TO MEET CUSTOMER'S REQUIREMENTS.

**LOXAHATCHEE RIVER DISTRICT**

**RESIDENTIAL SIMPLEX  
ELECTRICAL SCHEMATIC**

**LP-8**

N.T.S.  
REVISION:  
APRIL, 2012

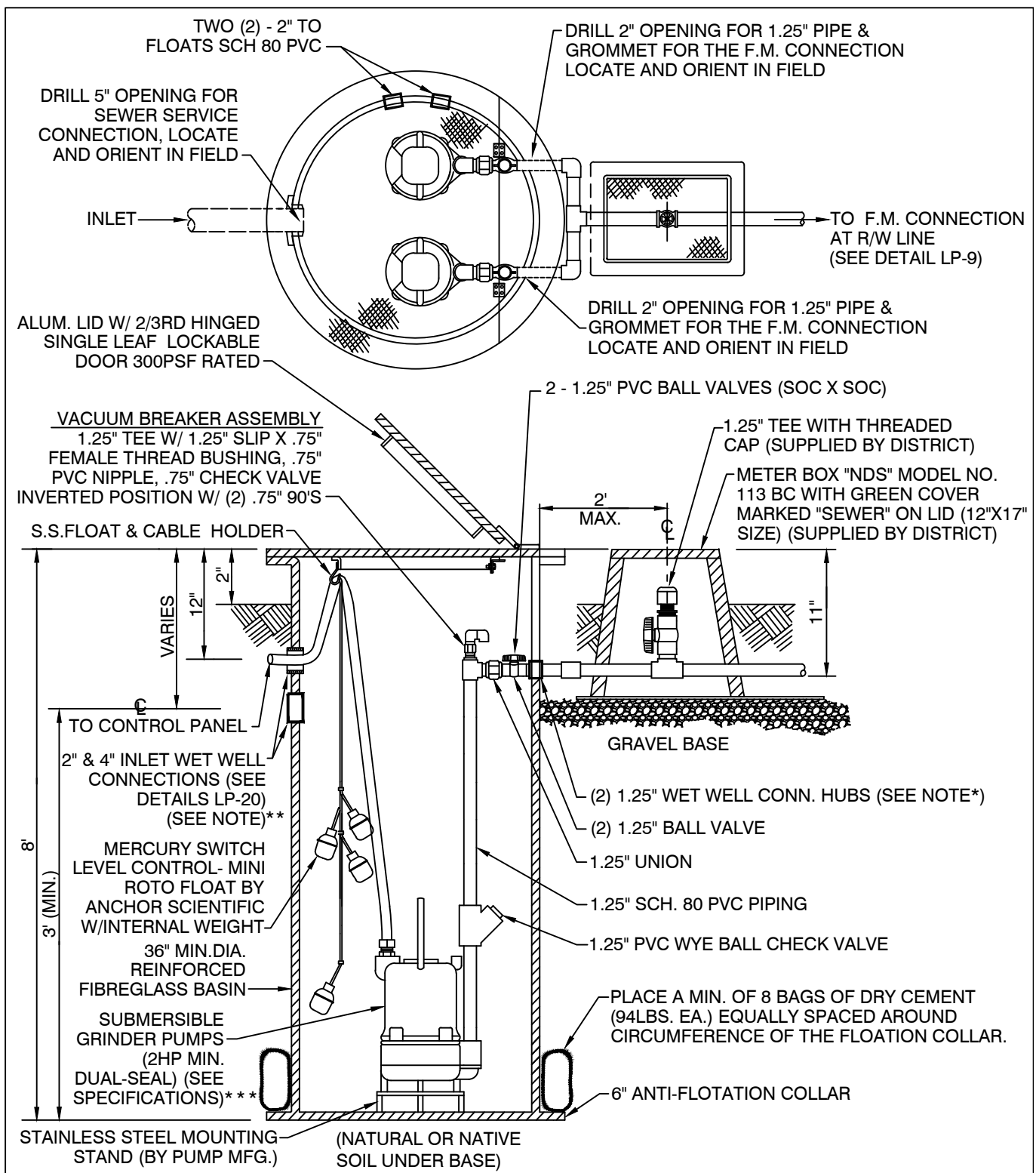

\*NOTE:  
CONNECTOR HUBS FOR WET-WELL FORCE MAIN CONNECTION ARE FACTORY INSTALLED. USE THREADED PVC SCH. 80 NIPPLES.

\*\*NOTE:  
CONNECTION TO WET-WELL FOR ELECTRICAL AND SEWER OPENINGS SHALL BE INSTALLED BY CONTRACTOR WITH 2" & 4" RUBBER GROMMETS SUPPLIED BY THE DISTRICT, LOCATION DETERMINED BY CONTROL PANEL LOCATION.

\*\*\*PUMP SPECIFICATIONS:  
BARNES-GRINDER PUMPS #SGVF2022L, 2HP, 230V, 1PH, 60HZ, 5.13" IMPELLER

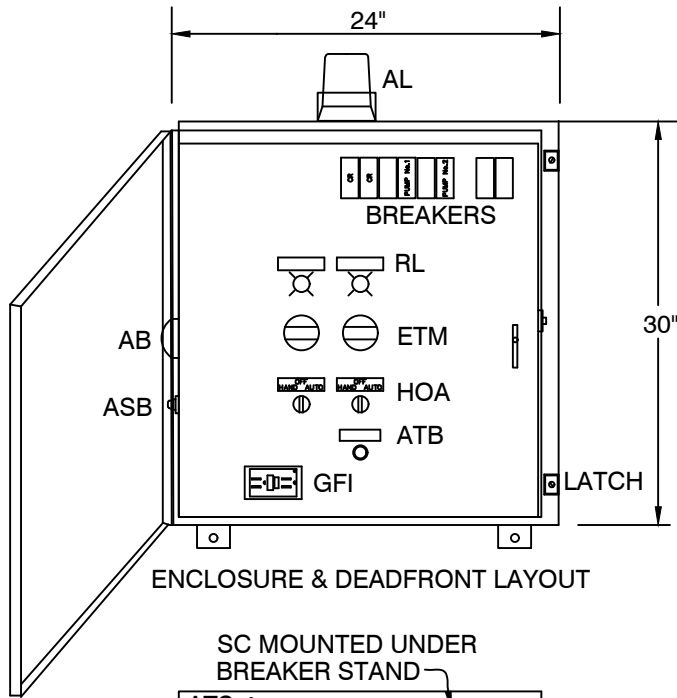

ENCLOSURE & DEADFRONT LAYOUT

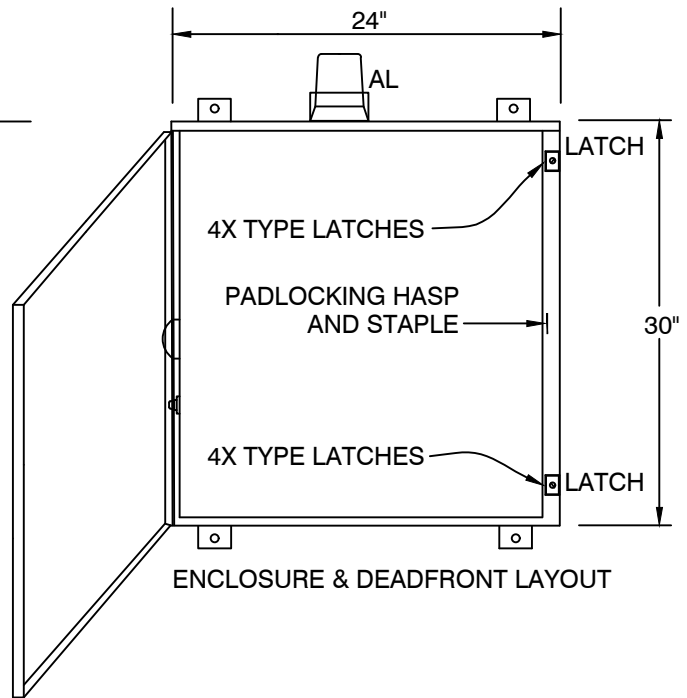

ENCLOSURE & DEADFRONT LAYOUT

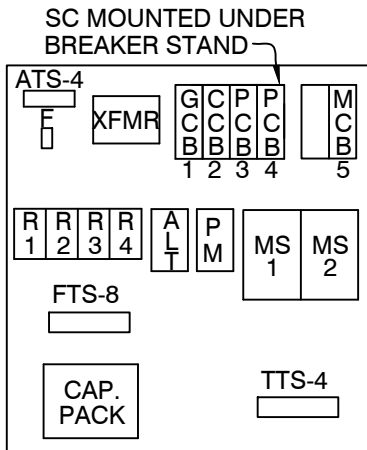

BACKPLATE LAYOUT TYPICAL

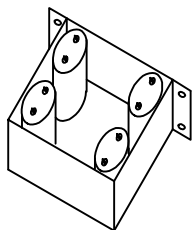

CAPACITOR  
PACK SUPPORT  
DETAIL

BILL OF MATERIALS

ENC	FIBERGLASS ENCLOSURE	HOFFMAN, UU605025
PCB/MCB	PUMP & MAIN BREAKERS	SQ-D, QOU260/QOU230
CCB/GCB	GFI & CONTROL BREAKERS	SQ-D, QOU115/QOU110
MS1-2	STARTER	SQ-D, 8502SBO1V02S
OL	OVL D HTR ELEMENT	SQ-D, B25
XFMR	TRANSFORMER	SQ-D, 9070T50D13
ETM	ELAPSED TIME METER	REDINGTON, 7220004
HOA	HAND OFF AUTO SWITCH	SQ-D, ZB4BD3
RL	RUN LIGHT	BACO 22M, S20SA40
AL	ALARM LIGHT	STONCO, VP11GCR
AH	ALARM HORN	FLOYD BELL, MC09201Q
ASR	ALARM SILENCE RELAY	IDEC, RR3BULAC120V
ASB	ALARM SILENCE BUTTON	SQ-D, ZB4BA0
ATB	ALARM TEST BUTTON	SQ-D, ZB4BA2
GFI	15 AMP GFI RCPT	PASS SEYMOUR, 1595W
FU1	FUSE 1A	BUSS, MDL-1
FU2	FUSE 2A	BUSS, MDL-2
FU1-2	FUSE BLOCK	BUSS, BKS82021
OL1-2	OVERLOAD RELAY	SQ-D, 9065SEO5
CR1-3	CONTROL RELAY	IDEC, RR2PULAC24V
ALT	ALTERNATOR	DIVERSIFIED, ARB120ABA
LA	LIGHTNING ARRESTOR	INTERMATIC, AG2401C
CAP.PACK: MARS RUN CAP OVAL 45MF/440V, 12448 } TO MATCH MARS STRT CAP 250V 124-156MF, 11148 } GRINDER PUMP'S GE START RELAY, 16104 }		

LOXAHATCHEE RIVER DISTRICT

RESIDENTIAL DUPLEX  
CONTROL PANEL LAYOUT

LP-10

N.T.S.

REVISION:  
APRIL, 2012



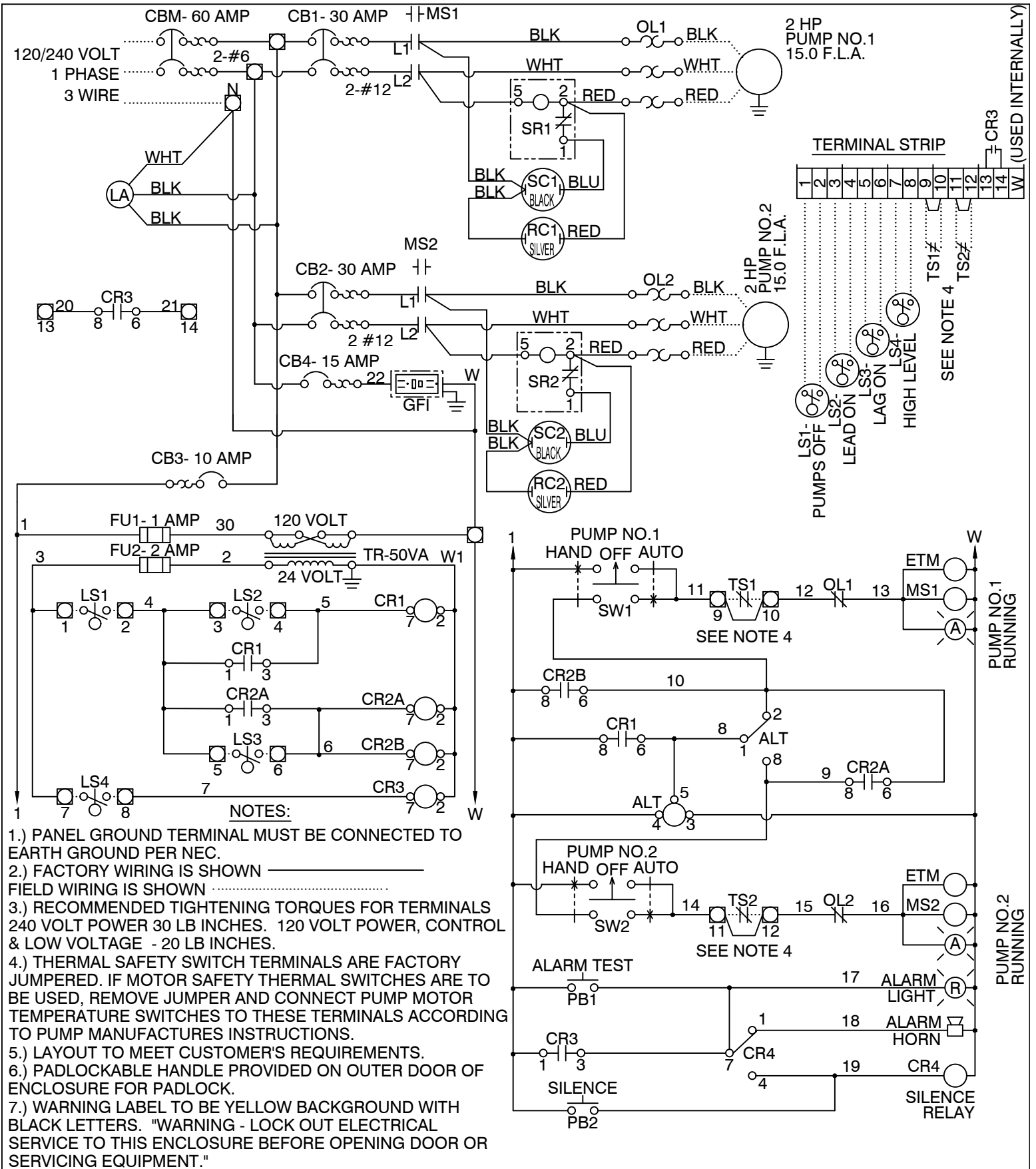

LOXAHATCHEE RIVER DISTRICT

RESIDENTIAL DUPLEX  
ELECTRICAL SCHEMATIC

LP-11

N.T.S.  
REVISION:  
APRIL, 2012

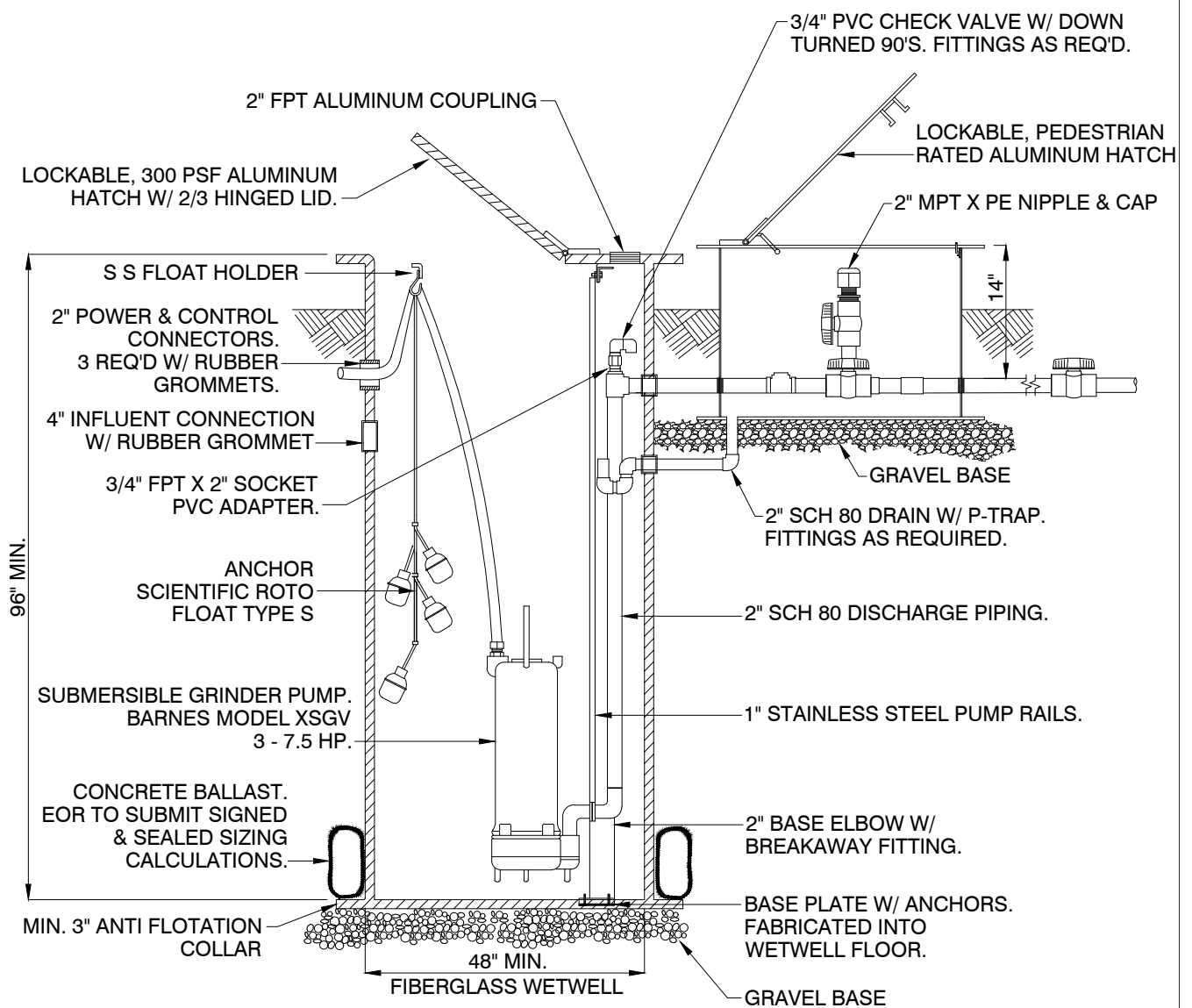
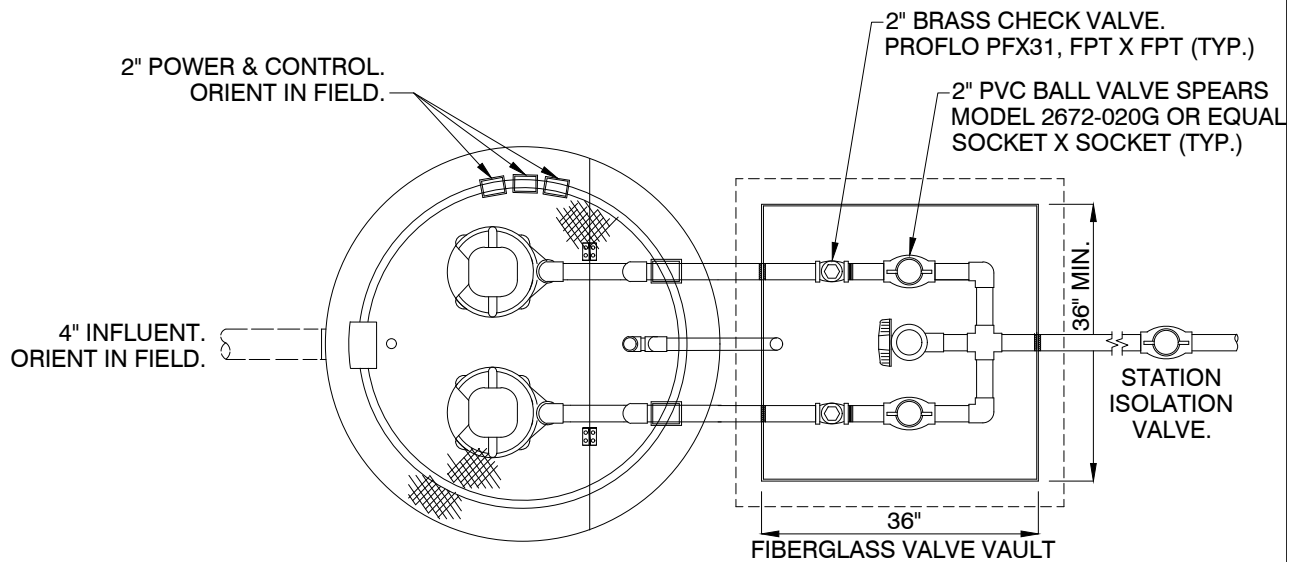

LOXAHATCHEE RIVER DISTRICT  
**COMMERCIAL DUPLEX  
 TYPICAL WET WELL**

LP-12

N.T.S.

REVISION:  
 JUNE, 2015

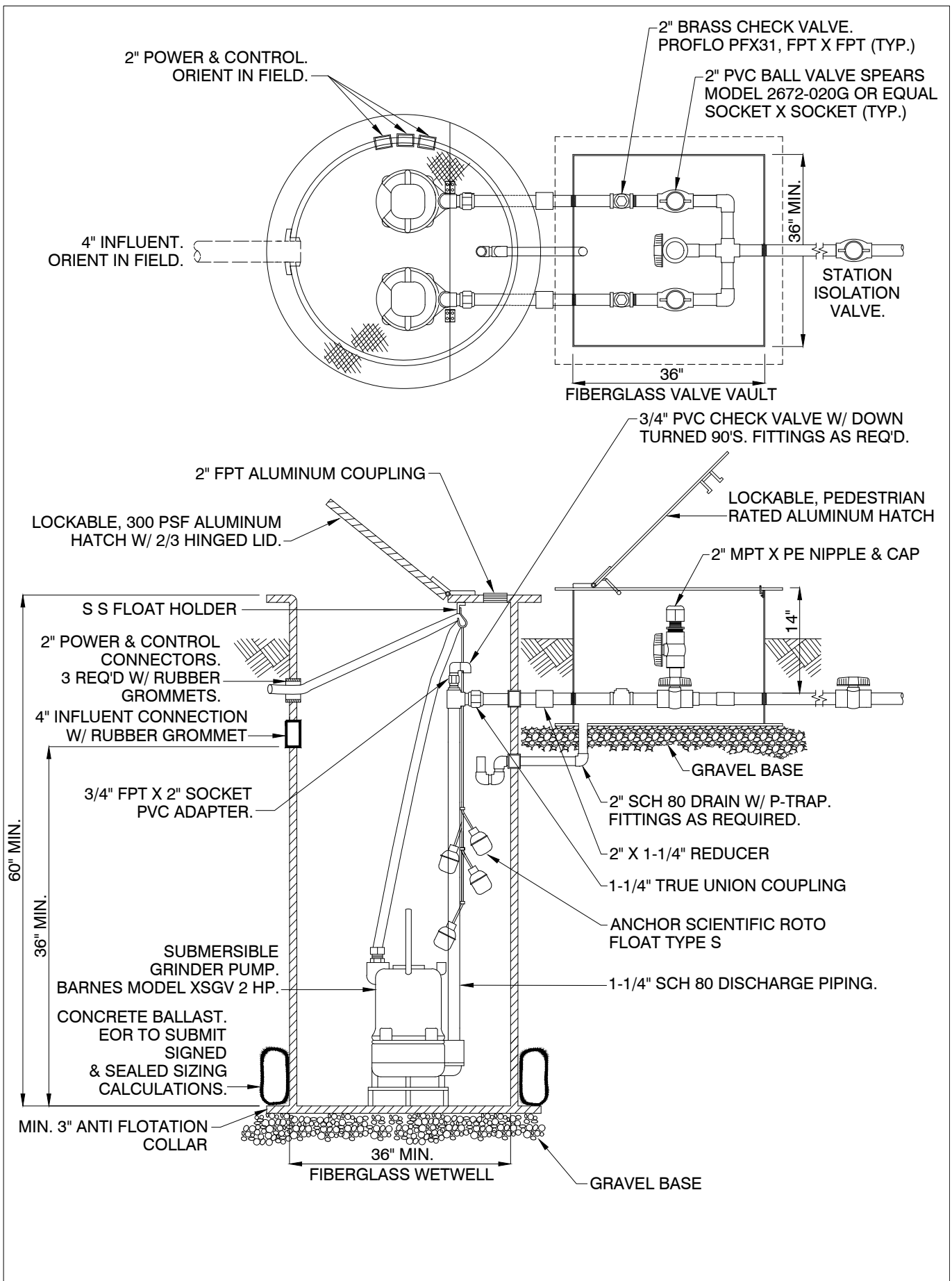

LOXAHATCHEE RIVER DISTRICT

COMMERCIAL DUPLEX  
TYPICAL LOW FLOW WET WELL

LP-12 ALT

N.T.S.

REVISION:  
JUNE, 2015

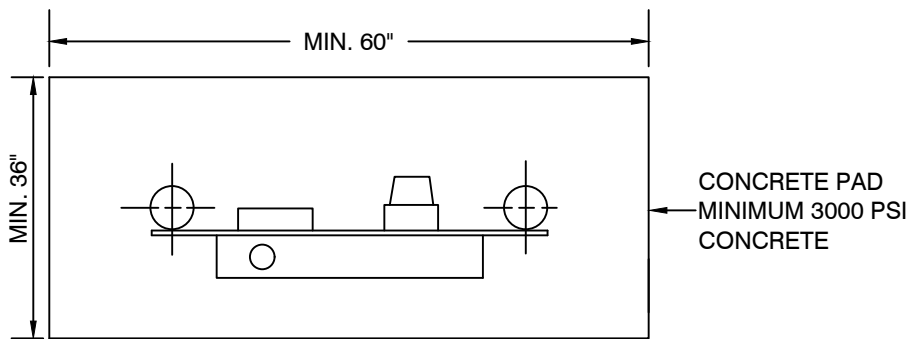

PLAN VIEW

304 SS FUSED DISCONNECT.  
SQUARE D MODEL H \*\*\* DS OR EQUAL.  
SIZE PER PUMP REQUIREMENTS.

MIN. 60 AMP

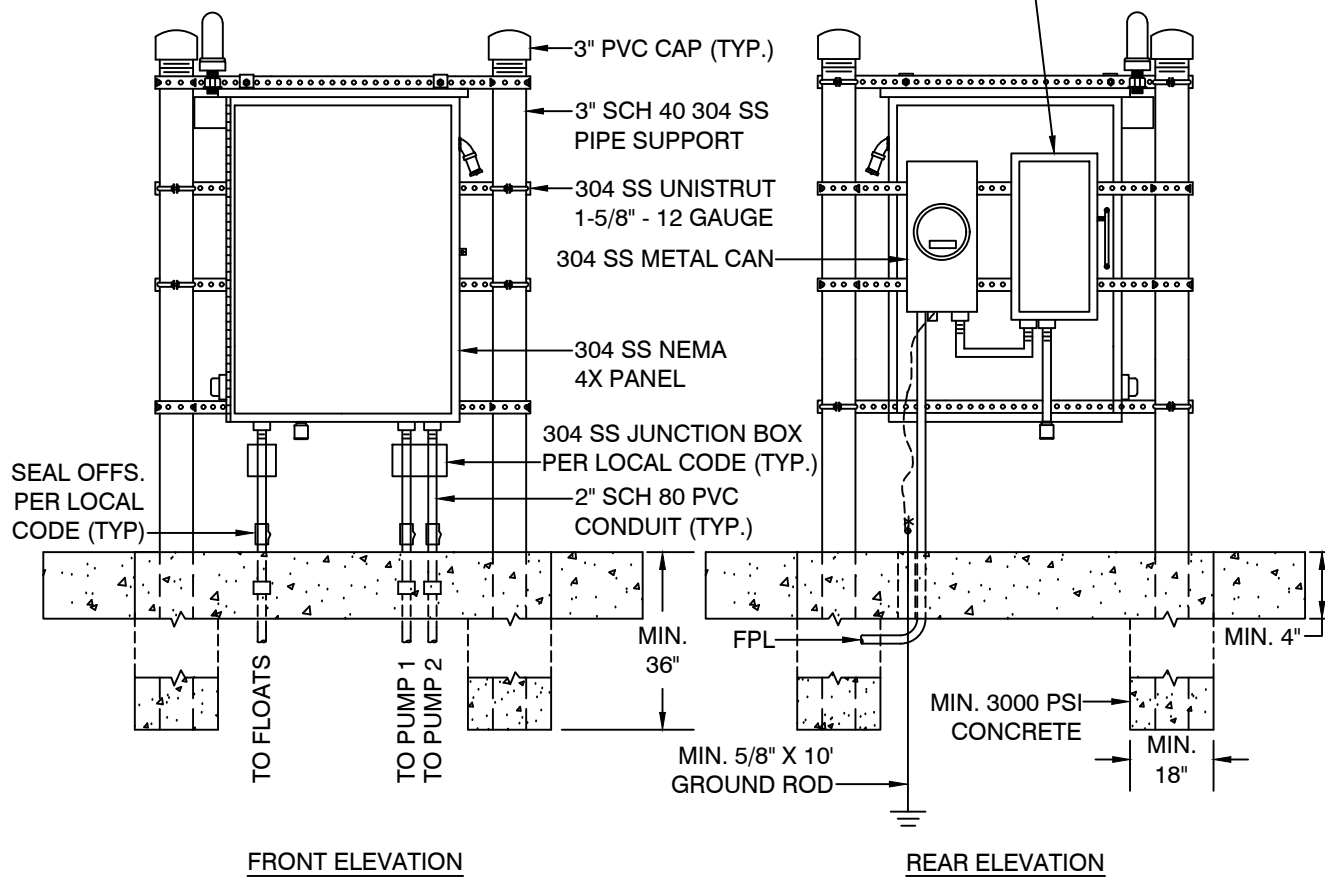

1. PROVIDE 4" SCH 40 PVC CHASE THROUGH CONCRETE SLAB DIRECTLY BELOW METER CAN FOR GROUND ROD. CLAMPED CONNECTION ON GROUND ROD TO BE 4" ABOVE SLAB.

2. ALL HARDWARE SHALL BE 316 SS.

LOXAHATCHEE RIVER DISTRICT

COMMERCIAL DUPLEX  
CONTROL PANEL SUPPORT

LP-13

N.T.S.

REVISION:  
JUNE, 2015

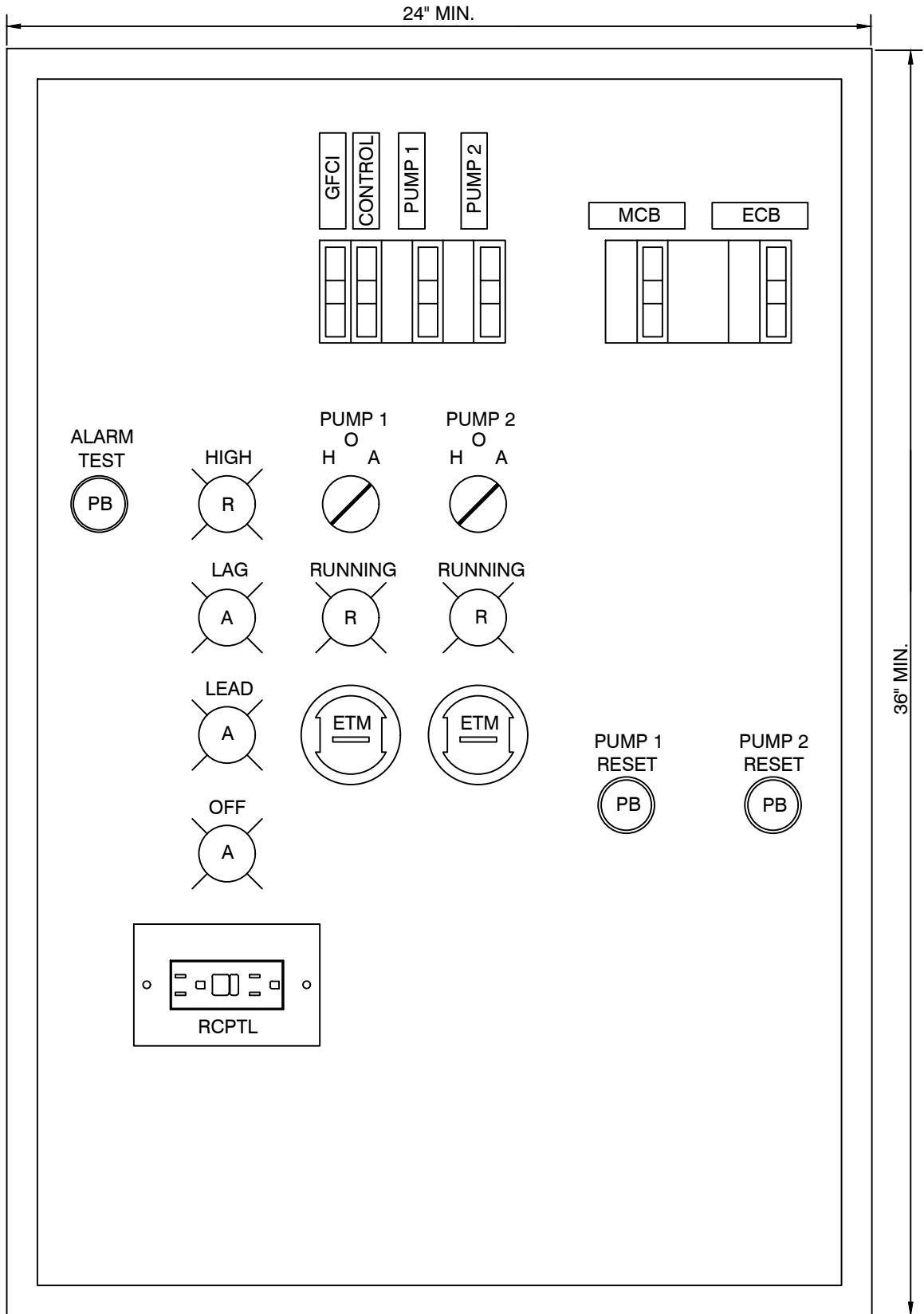

LOXAHATCHEE RIVER DISTRICT

COMMERCIAL DUPLEX CONTROL PANEL  
DEADFRONT LAYOUT

LP-14

N.T.S.

REVISION:  
JUNE, 2015

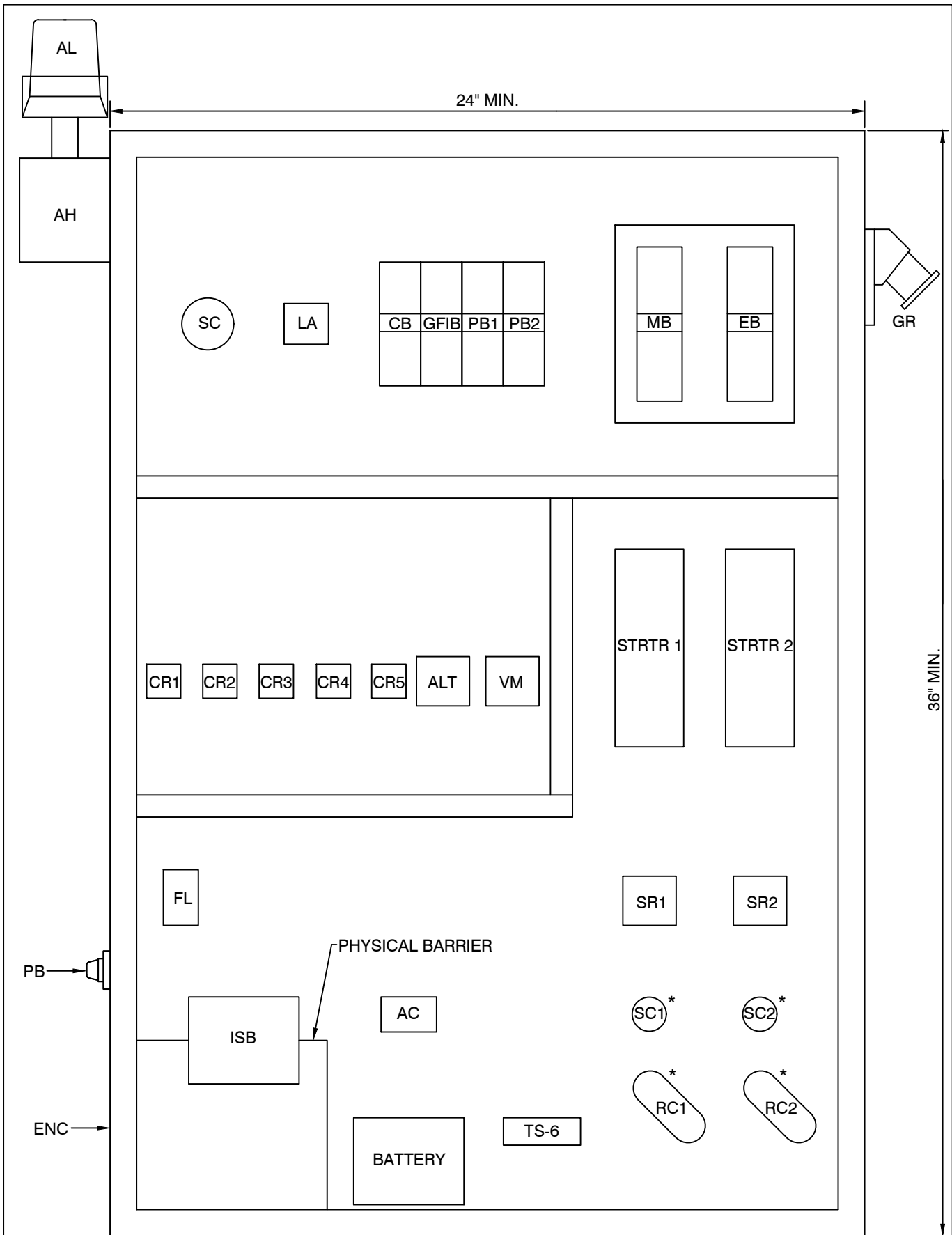

\* SINGLE PHASE PANEL ONLY

LOXAHATCHEE RIVER DISTRICT

COMMERCIAL DUPLEX CONTROL PANEL  
BACKPLATE LAYOUT

LP-15

N.T.S.

REVISION:  
JUNE, 2015

ITEM	DESCRIPTION	PART NO. SINGLE PHASE	PART NO. THREE PHASE	QTY
AC	ALARM CONTROLLER	MPE MODEL BOAC-001	MPE MODEL BOAC-001	1
AH	ALARM HORN	WHEELOCK AMT-12/24-R	WHEELOCK AMT-12/24-R	1
AL	ALARM LIGHT	CONDOR/GRAINGER 2ERP1	CONDOR/GRAINGER 2ERP1	1
ALT	ALTERNATOR	ATC DIVERSIFIED ELECTRONICS: ARB120AEA	ATC DIVERSIFIED ELECTRONICS: ARB120AEA	1
BAT	BATTERY	WERKER MODEL MWA12-7F	WERKER MODEL MWA12-7F	1
CR*	CONTROL RELAY	IDEC: RR 2 BA - U L AC120V	IDEC: RR 2 BA - U L AC120V	5
ETM	ELAPSED TIME METER	CONTROL DYNAMICS: HMA303	CONTROL DYNAMICS: HMA303	2
ENC*	ENCLOSURE NEMA 4X SS	HOFFMAN: CSD362410SS W/ DRIP SHIELD AND LOCKING HASP	HOFFMAN: CSD362410SS W/ DRIP SHIELD AND LOCKING HASP	1
FL	FLASHER	LIGHTS TO GO: AFDC 1	LIGHTS TO GO: AFDC 1	1
GR	GENERATOR RECEPTACLE	APPLETON: ADR1034RS	APPLETON: ADR1034RS	1
GFIB, CB	GFI & CONTROL BREAKER	SQUARE-D: QOU115	SQUARE-D: QOU115	2
	HAND OFF AUTO SWITCH	SUARE-D: 9001KS46B	SUARE-D: 9001KS46B	2
ISB	INTRINSICALLY SAFE BARRIER	IDEC: EB3C-R05A	IDEC: EB3C-R05A	1
LA	LIGHTNING ARRESTOR	SQUARE-D: SDSA1175	SQUARE-D: SDSA3650	1
MB, EB	MAIN & EMERGENCY BREAKERS	SQUARE-D: QOU2***	SQUARE-D: QOU3***	2
TU	THERMAL UNIT	SQUARE-D: B36.0	SQUARE-D: B36.0	2
	PILOT LIGHTS	BACO CONTROLS: NLD22* (COLOR AS INDICATED)	BACO CONTROLS: NLD22* (COLOR AS INDICATED)	6
PB***	PUMP BREAKERS	SQUARE-D: QOU2***	SQUARE-D: QOU3***	2
STRTR***	STARTER	SQUARE-D: 8536SCO2V02S	SQUARE-D: 8536SCO3V02S	2
SC	SURGE CAPACITOR	DELTA: CA302R	DELTA: CA603R	1
PB	TEST/RESET/SILENCE PUSH BUTTONS	SQUARE-D: 9001SKR1U	SQUARE-D: 9001SKR1U	1
VM	VOLTAGE MONITOR	ATC DIVERSIFIED ELECTRONICS: UOA240ALA	ATC DIVERSIFIED ELECTRONICS: SLA-***-***	1
RCPTL	15 AMP GFI RECEPTACLE	PASS AND SEYMOUR: 1595W	PASS AND SEYMOUR: 1595W	1
SC***	START CAPACITOR	***	NOT REQUIRED	2
RC***	RUN CAPACITOR	***	NOT REQUIRED	2

\* HOFFMAN: UU1008030 FOR COMMERCIAL DUPLEX LOW FLOW OPTION  
\*\*\* SIZED PER PUMP MANUFACTURER'S RECOMMENDATION

LOXAHATCHEE RIVER DISTRICT

N.T.S.	<b>COMMERCIAL DUPLEX CONTROL PANEL BILL OF MATERIALS</b>	<b>LP-16</b>
REVISION: JUNE, 2015		

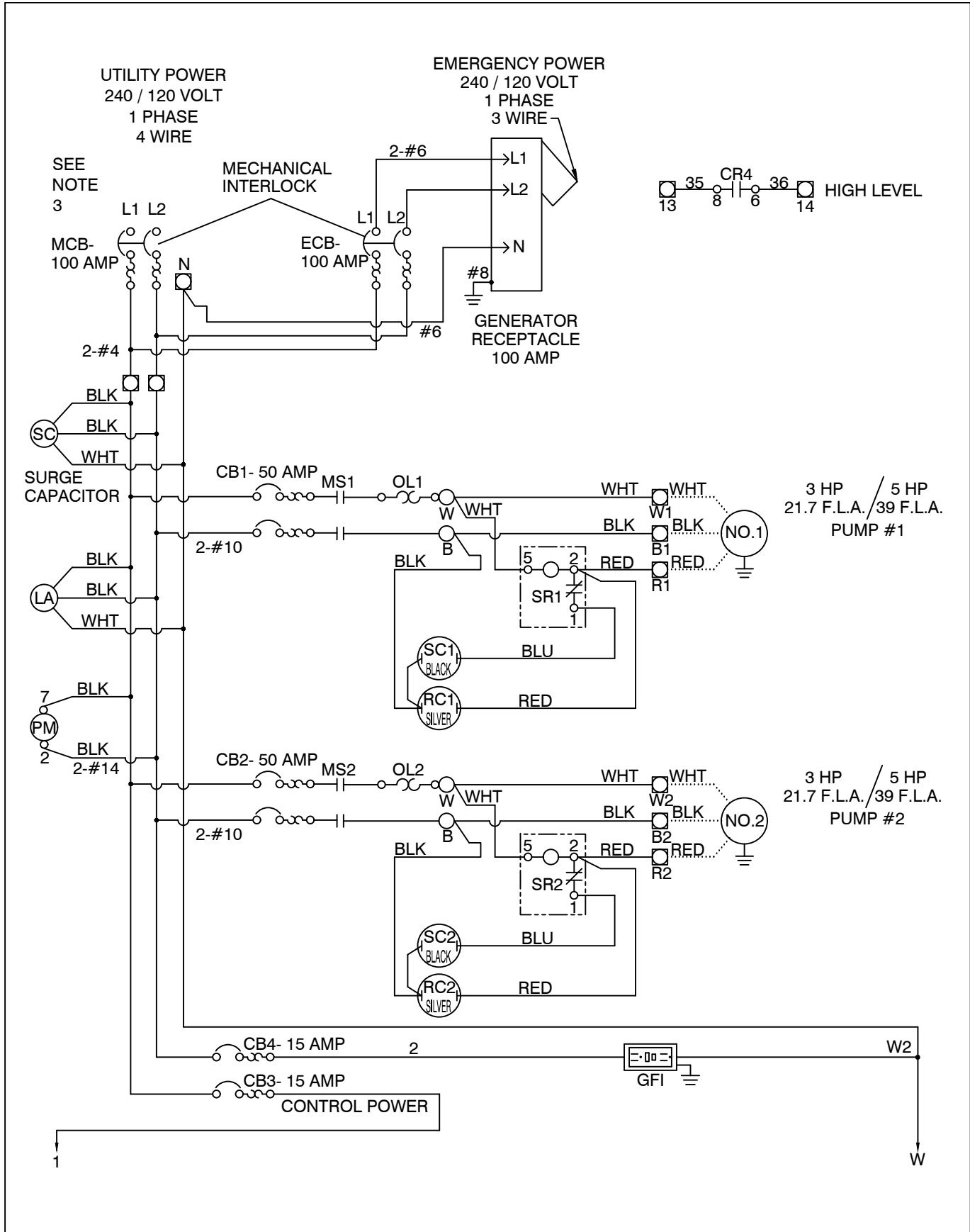

CONTINUED ON COMMERCIAL DUPLEX ELECTRICAL SCHEMATIC CONTROL CIRCUIT

LOXAHATCHEE RIVER DISTRICT

N.T.S.  
REVISION:  
JUNE, 2015

COMMERCIAL DUPLEX  
ELECTRICAL SCHEMATIC 1PHASE

LP-17



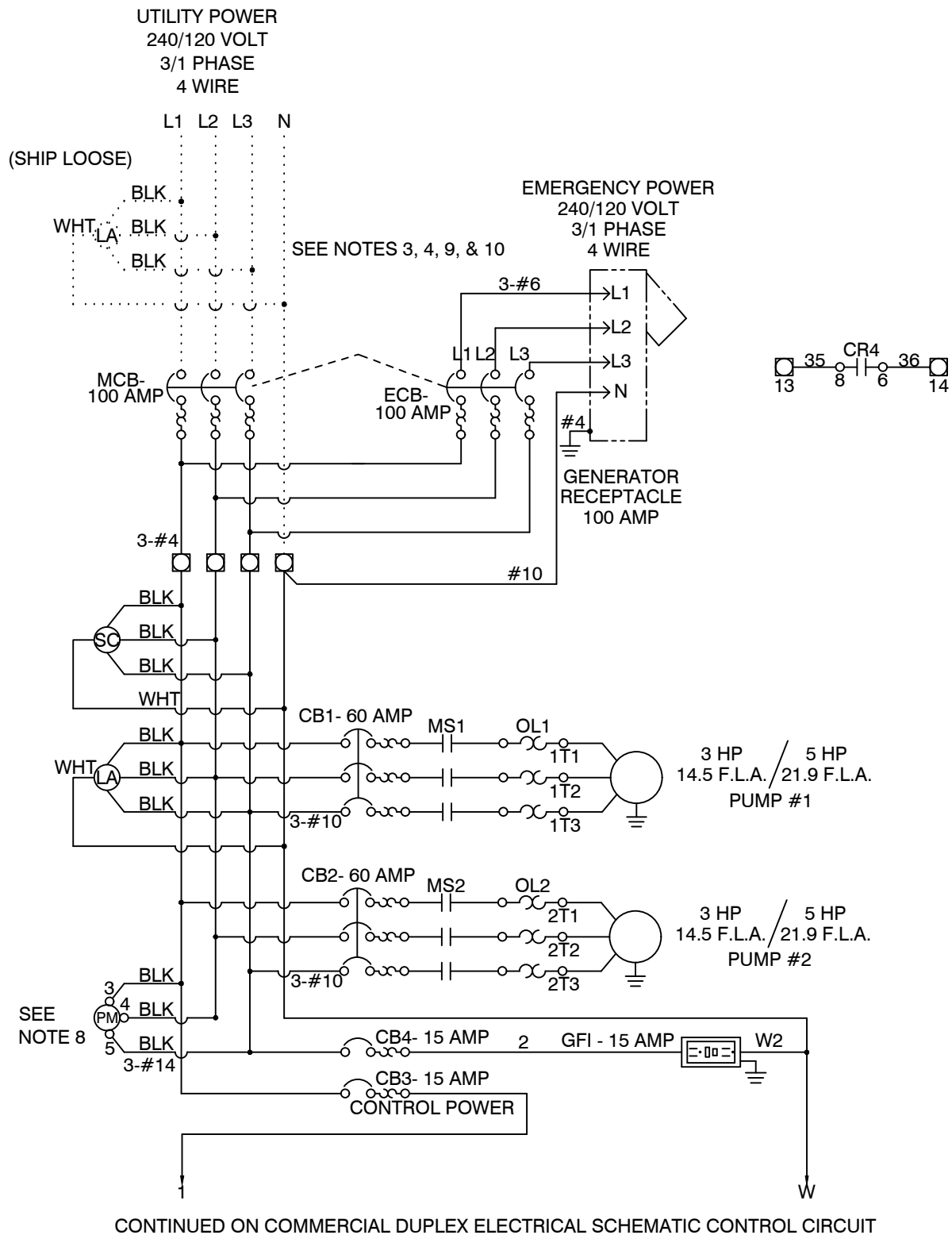

LOXAHATCHEE RIVER DISTRICT

N.T.S.  
REVISION:  
JUNE, 2015

COMMERCIAL DUPLEX  
ELECTRICAL SCHEMATIC 3PHASE

LP-18

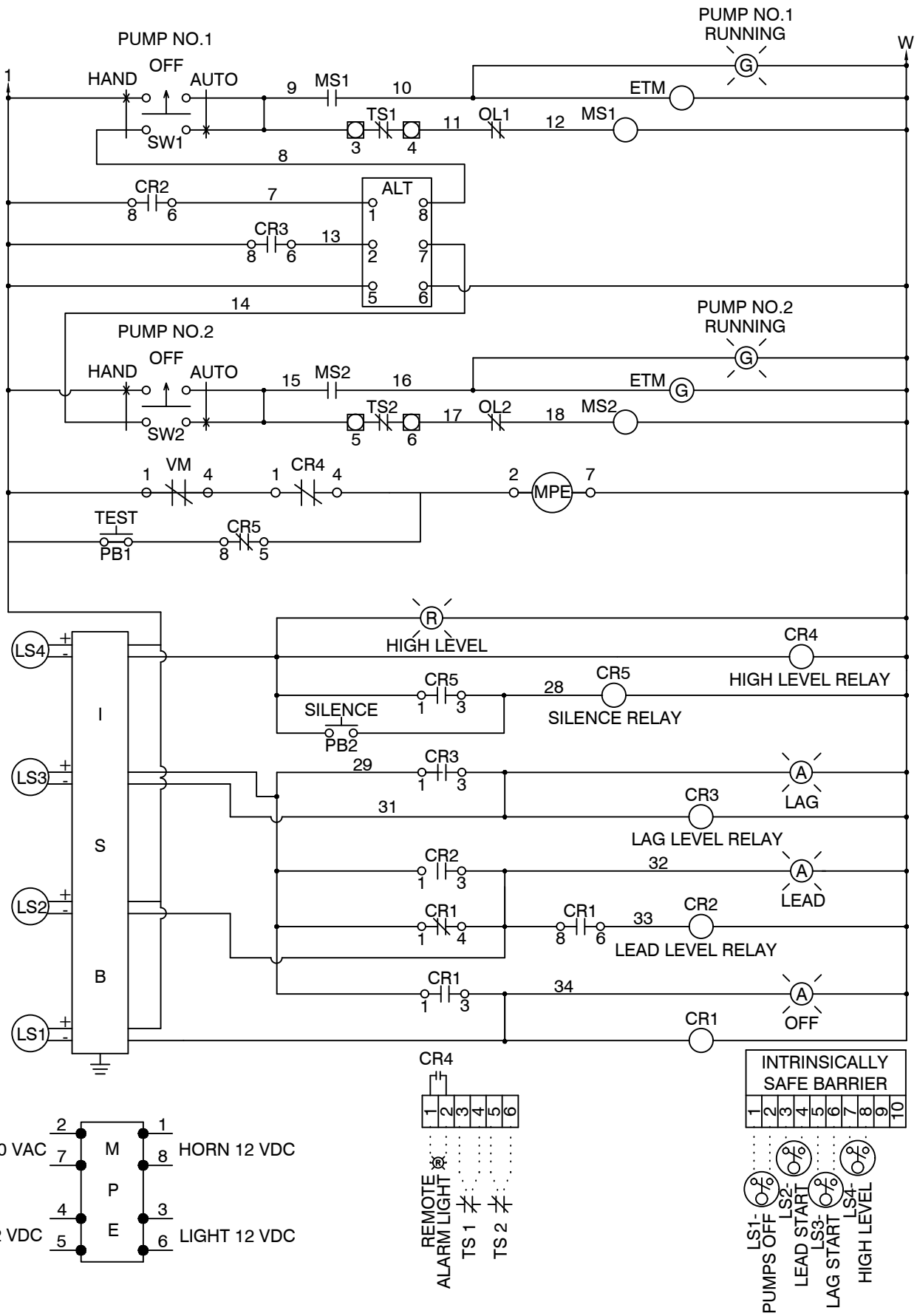

LOXAHATCHEE RIVER DISTRICT

N.T.S.

REVISION:  
JUNE, 2015

COMMERCIAL DUPLEX  
ELECTRICAL SCHEMATIC CONTROL CIRCUIT

LP-19

**NOTES:**

- 1.) PANEL GROUND TERMINAL MUST BE CONNECTED TO EARTH GROUND.
- 2.) FACTORY WIRING IS SHOWN \_\_\_\_\_  
FIELD WIRING IS SHOWN . . . . .
- 3.) INSTALLER MUST PROVIDE SHORT CIRCUIT PROTECTION FOR THE CONDUCTORS FEEDING TO THIS ELECTRICAL ASSEMBLY.
- 4.) RECOMMENDED TIGHTENING TORQUES FOR TERMINALS; 240 VOLT POWER - SEE CIRCUIT BREAKER 120 VOLT POWER, CONTROL & LOW VOLTAGE - 20 POUND INCHES
- 5.) THERMAL SAFETY SWITCH (TS) CONTACTS ARE NOT IN ALL MOTORS. IF MOTOR DOES NOT HAVE SWITCH, THESE TERMINALS MUST BE JUMPERED.
- 6.) HASP AND STAPLE PROVIDED ON OUTER DOOR OF ENCLOSURE FOR PADLOCK.
- 7.) WARNING LABEL TO BE YELLOW BACKGROUND WITH BLACK LETTERS. "WARNING - LOCK OUT ELECTRICAL SERVICE TO THIS ENCLOSURE BEFORE OPENING DOOR OR SERVICING EQUIPMENT".
- 8.) ON START UP, THE POWER MONITOR INDICATOR LIGHT SHOULD TURN "ON" WITHIN ONE (1) SECOND. IF IT DOESN'T, TURN POWER "OFF" TO THE PANEL & SWAP ANY TWO (2) OF THE THREE (3) INPUT WIRES TO THE MONITOR.
- 9.) MAIN CIRCUIT BREAKER AND EMERGENCY CIRCUIT BREAKER INTERLOCKED TO PREVENT SIMULTANEOUS CLOSURE.
- 10.) INSTALLER MUST VERIFY THAT PHASE TO NEUTRAL IS 120 VOLTS BEFORE CONNECTING CONTROL & RECEPTACLE CIRCUITS.
- 11.) WARNING LABEL TO BE RED WITH WHITE LETTERS: DO NOT OVERRIDE INTERLOCK NEVER ENERGIZE BOTH BREAKERS SIMULTANEOUSLY.

**LOXAHATCHEE RIVER DISTRICT**

N.T.S. REVISION: JUNE, 2015	<b>COMMERCIAL DUPLEX ELECTRICAL SCHEMATIC NOTES</b>	<b>LP-20</b>
-----------------------------------	---	--------------

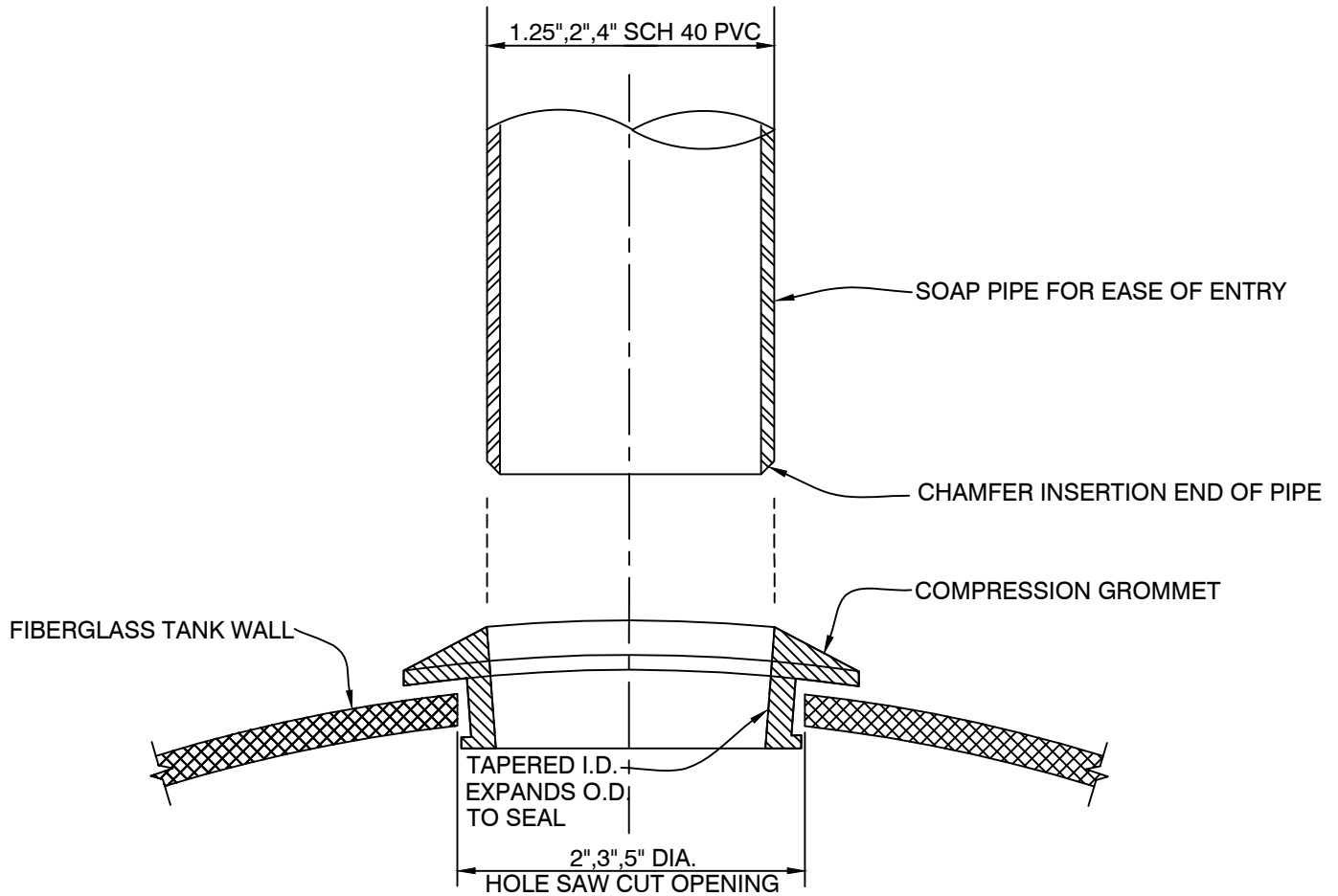

**NOTES:**

FOR A 4" PVC PIPE, USE A 5" DIA. HOLE SAW TO CUT OUT COUPON FROM WET WELL WALL. THE MANUFACTURER WILL SUPPLY THE PROPER COMPRESSION GASKET FOR A 4" DIA. PVC PIPE

FOR A 2" PVC PIPE, USE A 3" DIA. HOLE SAW TO CUT OUT COUPON FROM WET WELL WALL. THE MANUFACTURER WILL SUPPLY THE PROPER COMPRESSION GASKET FOR A 2" DIA. PVC PIPE

FOR A 1.25" PVC PIPE, USE A 2" DIA. HOLE SAW TO CUT OUT COUPON FROM WET WELL WALL. THE MANUFACTURER WILL SUPPLY THE PROPER COMPRESSION GASKET FOR A 1.25" DIA. PVC PIPE

TERMINATE INFLUENT SEWER LINE 3" INSIDE TANK.

**LOXAHATCHEE RIVER DISTRICT**

**PIPE CONNECTION DETAIL**

**LP-21**

N.T.S.

REVISION:  
APRIL, 2012

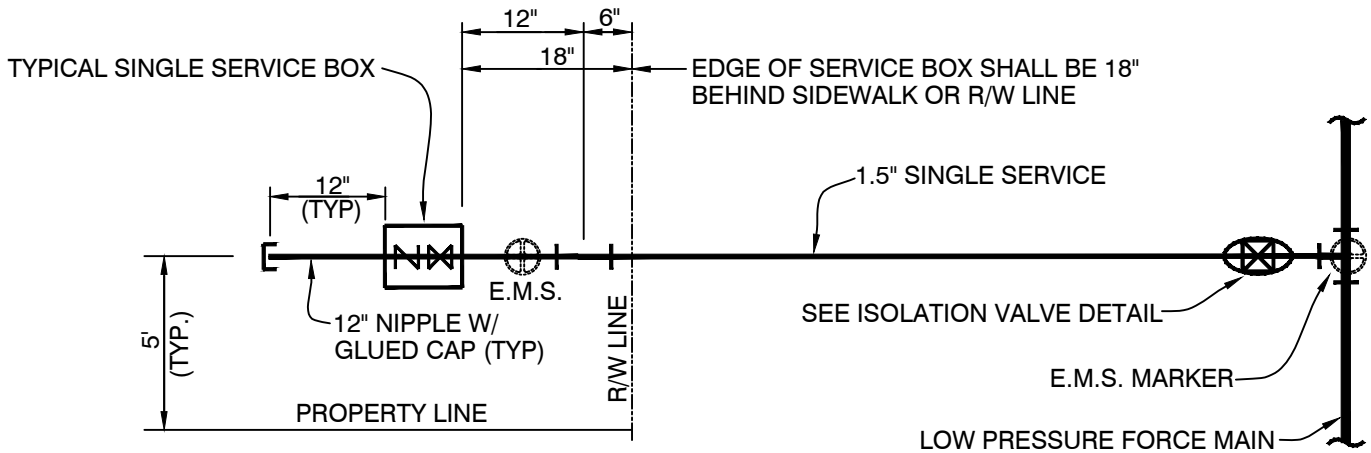

**PLAN VIEW**

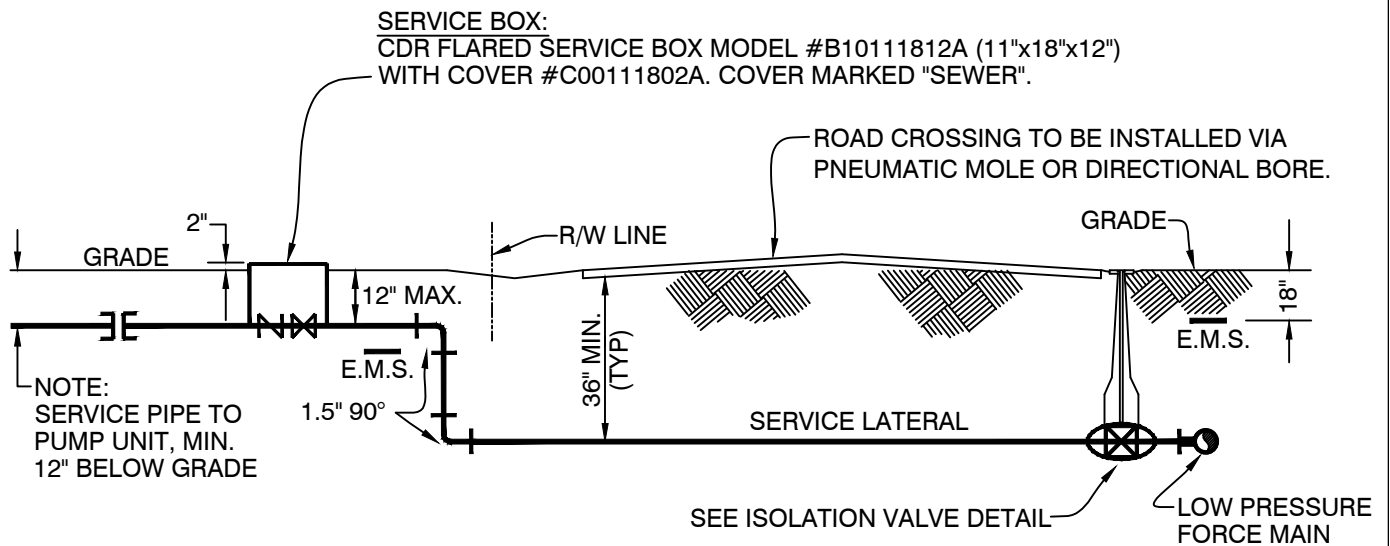

**TYPICAL ROAD CROSSING SECTION VIEW**

**NOTES:**

1. SERVICE LOCATIONS ON PLANS ARE APPROXIMATE. INSTALLED LOCATIONS TO BE COORDINATED WITH EXISTING ONSITE PLUMBING OR PROPOSED ONSITE CONSTRUCTION.
2. BALL VALVES SHALL BE FORD MODEL #B11-666M WITH 2" BRASS OPERATING NUT.
3. ALL CHECK VALVES SHALL BE PROFLO MODEL PFX31.
4. ALL PIPING IN AND 6-INCHES BEYOND THE SERVICE BOX SHALL BE SCH 80 PVC.
5. INSTALL MINIMUM 4" OF NO 57 WASHED STONE BENEATH ALL SERVICE BOXES AND VALVE BOXES AND AROUND ALL PIPE PENETRATIONS THROUGH SERVICE BOXES.
6. FOR HDPE TO PVC TRANSITIONS USE FORD PACK JOINT COUPLING PVC X PE W/ 304SS STIFFENER.

**LOXAHATCHEE RIVER DISTRICT**

**TYPICAL SINGLE SERVICE SCHEMATIC**

**LP-22**

N.T.S.

REVISION:  
MARCH, 2017

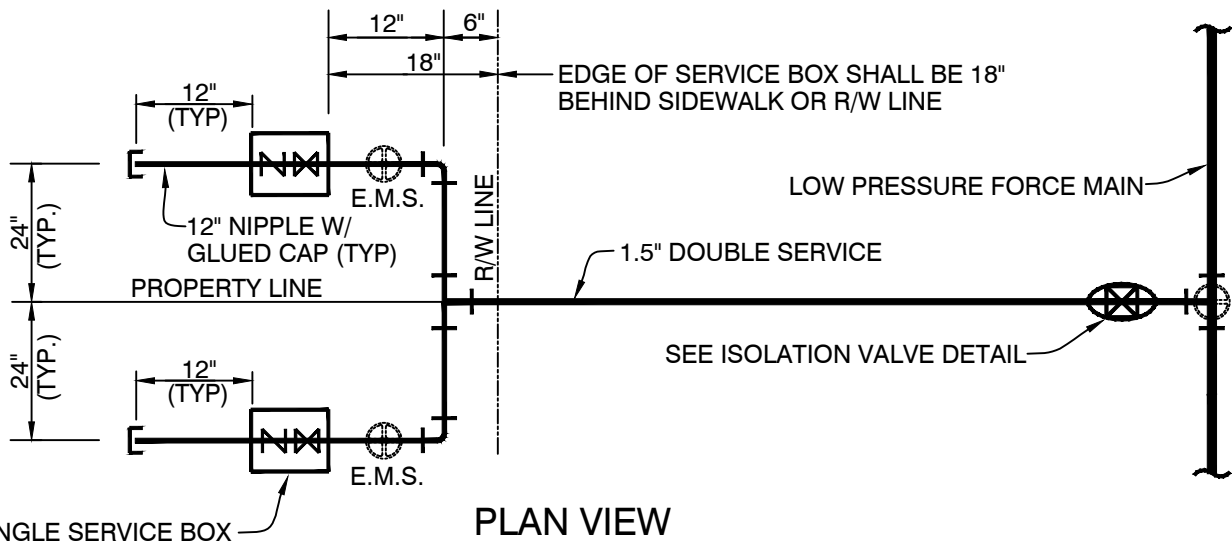

SERVICE BOX:  
 CDR FLARED SERVICE BOX MODEL #B10111812A (11"x18"x12")  
 WITH COVER #C00111802A. COVER MARKED "SEWER".

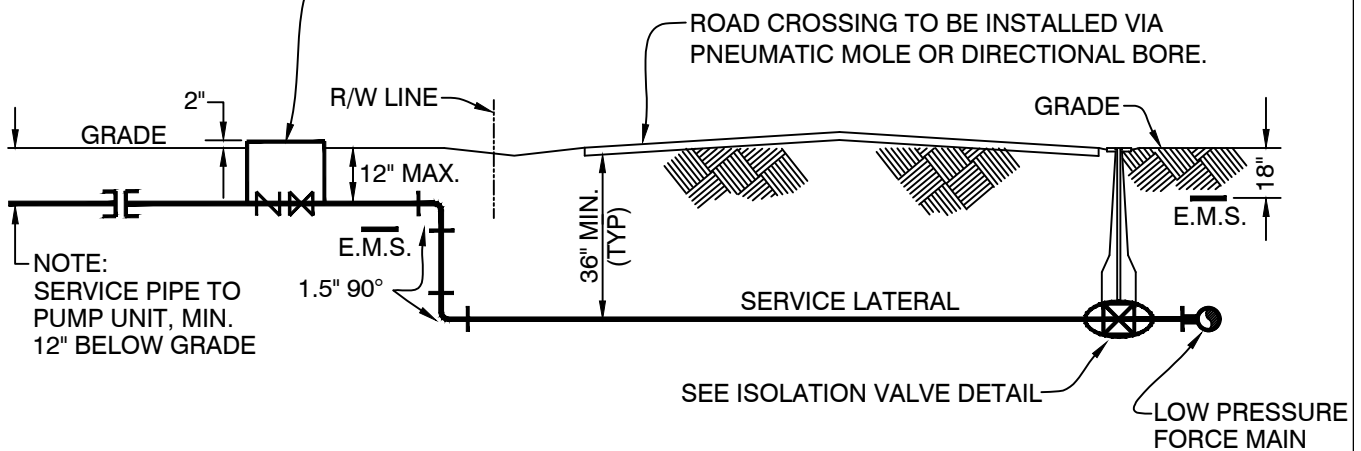

**NOTES:**

1. SERVICE LOCATIONS ON PLANS ARE APPROXIMATE. INSTALLED LOCATIONS TO BE COORDINATED WITH EXISTING ONSITE PLUMBING OR PROPOSED ONSITE CONSTRUCTION.
2. BALL VALVES SHALL BE FORD MODEL #B11-666M WITH 2" BRASS OPERATING NUT.
3. ALL CHECK VALVES SHALL BE PROFLO MODEL PFX31.
4. ALL PIPING IN AND 6-INCHES BEYOND THE SERVICE BOX SHALL BE SCH 80 PVC.
5. INSTALL MINIMUM 4" OF NO 57 WASHED STONE BENEATH ALL SERVICE BOXES AND VALVE BOXES AND AROUND ALL PIPE PENETRATIONS THROUGH SERVICE BOXES.
6. FOR HDPE TO PVC TRANSITIONS USE FORD PACK JOINT COUPLING PVC X PE W/ 304SS STIFFENER.

**LOXAHATCHEE RIVER DISTRICT**

**TYPICAL DOUBLE SERVICE SCHEMATIC**

**LP-23**

N.T.S.

REVISION:  
 MARCH, 2017

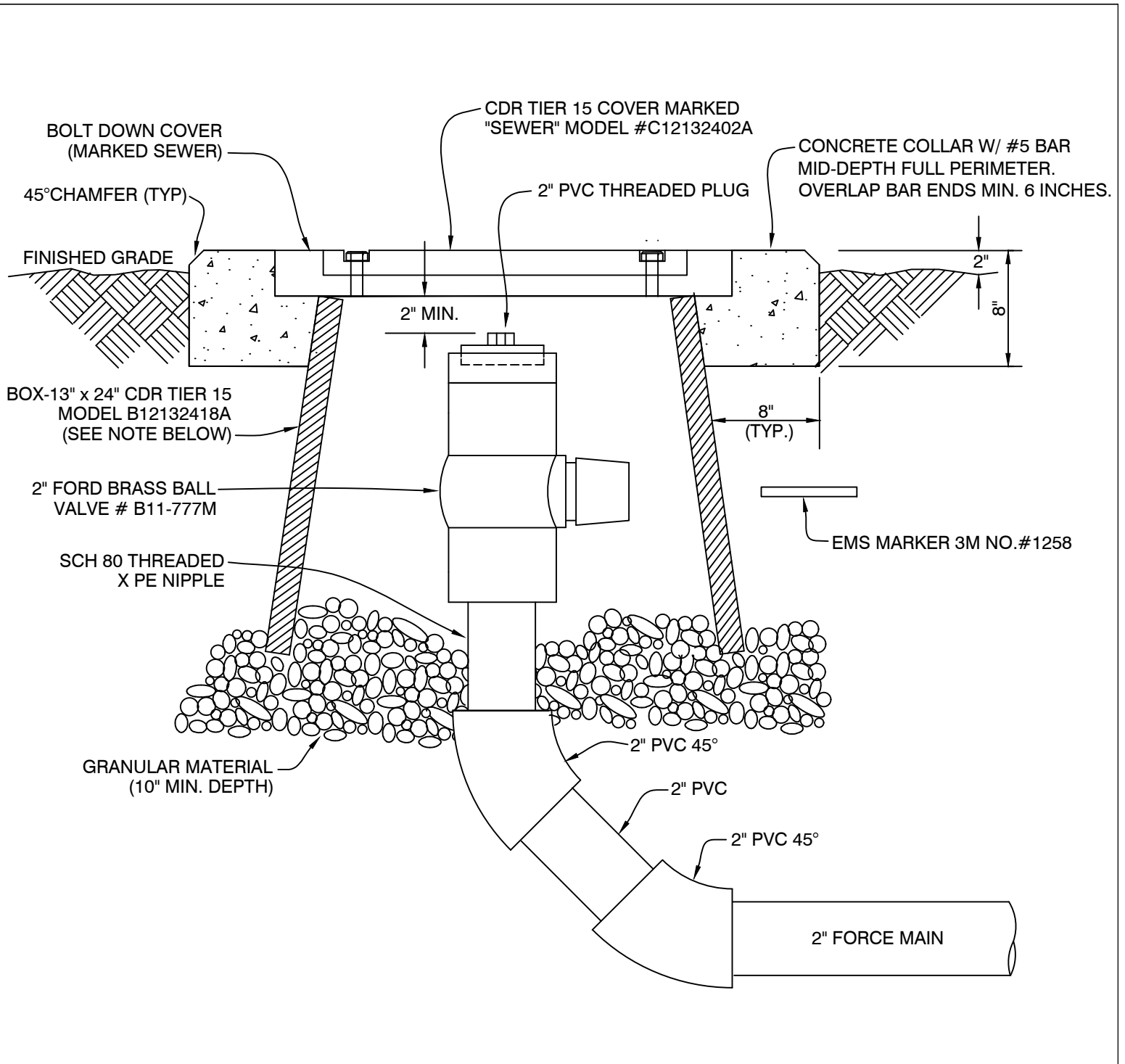

**NOTES:**

1. IN PAVED AREAS, USE NO. PB16"x24"x24" DEEP x 4" WALLS AND 4" FLOOR, AND NO. PB1624 TRAFFIC COVER DESIGNED FOR HS-20-44 TRAFFIC RATED BY BROOKS PRODUCTS INC.
2. INSTALL MIN. 4" OF NO 57 WASHED STONE BENEATH ALL TERMINAL END FLUSHING PORT BOXES.
3. ALL PIPING IN AND 6 INCHES BEYOND BOX SHALL BE SCH 80 PVC.
4. FOR HDPE TO PVC TRANSITIONS USE FORD PACK JOINT COUPLING PVC x PE W/ 304SS STIFFENER.

**LOXAHATCHEE RIVER DISTRICT**

N.T.S.
REVISION: MARCH, 2017

**TERMINAL FLUSHING PORT DETAIL**

**LP-24**

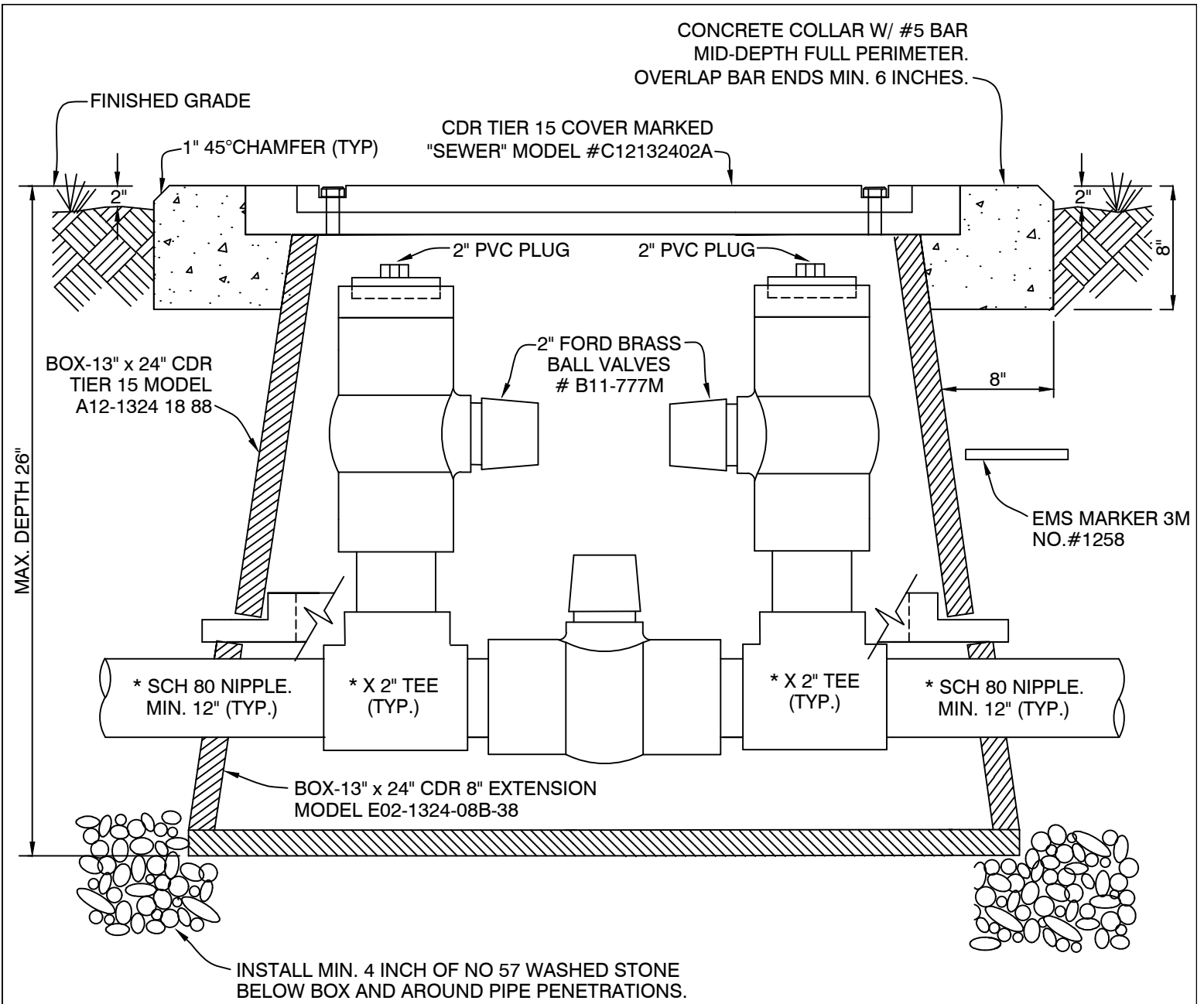

\* SIZED BY ENGINEER

USE VALVE BOX AND FLUSHING PORTS ALONG STRAIGHT RUNS IN FORCE MAIN.

**NOTES:**

1. IN PAVED AREAS, USE NO. PB16"x24"x24" DEEP x 4" WALLS AND 4" FLOOR, AND NO. PB1624 TRAFFIC COVER DESIGNED FOR HS-20-44 TRAFFIC RATED BY BROOKS PRODUCTS INC.
2. PUMP TAP VALVES TO BE 2" FORD BRASS BALL VALVES # B11-777M W/ SCH 80 THREADED x PE NIPPLES AS REQUIRED. INLINE VALVE TO MATCH FORCE MAIN DIAMETER.

**LOXAHATCHEE RIVER DISTRICT**

N.T.S.
REVISION: MARCH, 2017

**IN LINE FLUSHING PORT**

**LP-25**



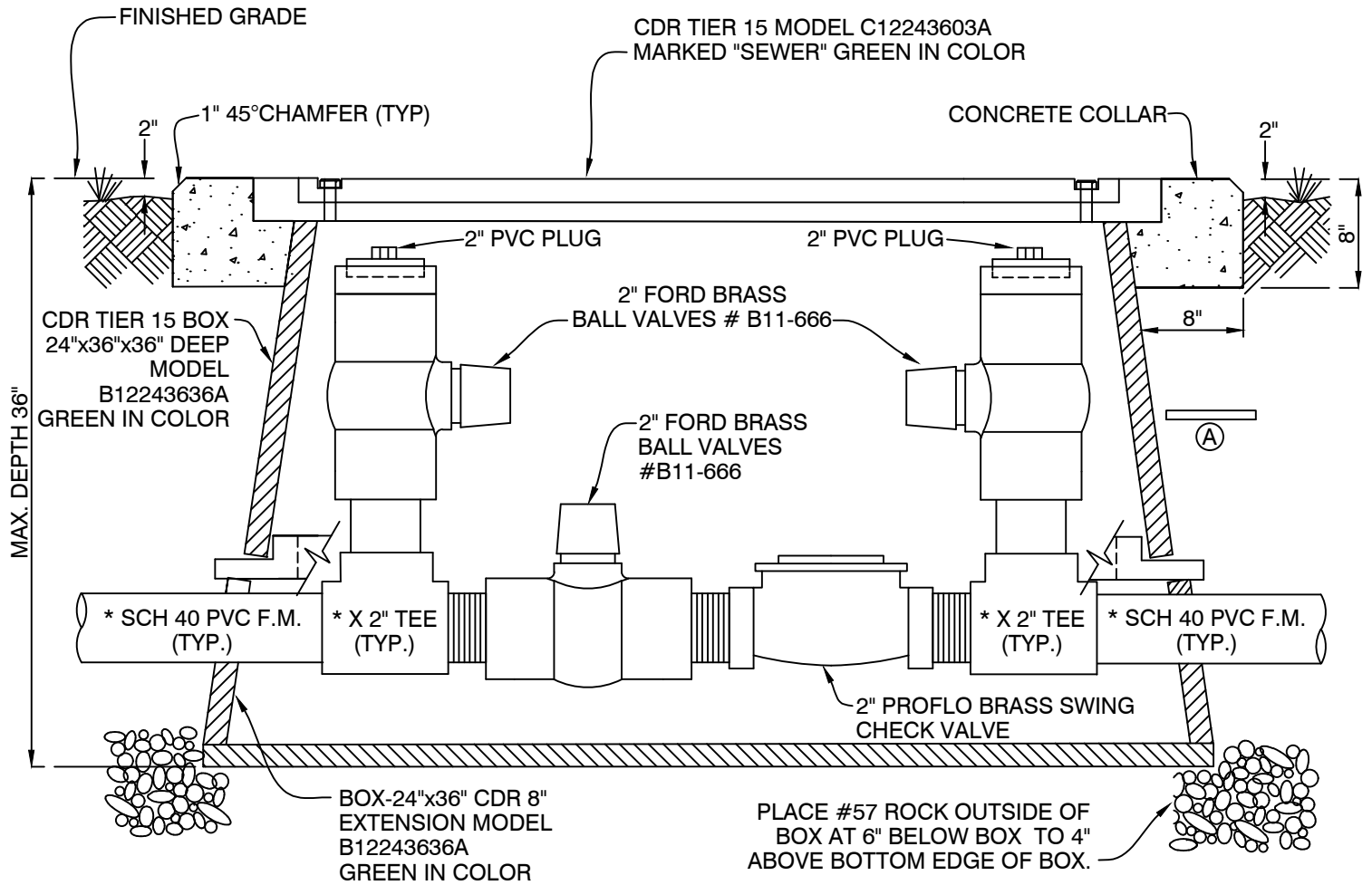

(A) - EMS MARKER NO.#1258 ELECTRONIC MARKER SYSTEM AS MFG. BY 3M TEST AND MEASUREMENT SYSTEM AUSTIN, TEXAS

\* SIZED BY ENGINEER  
USE VALVE BOX AND FLUSHING PORTS ALONG STRAIGHT RUNS IN FORCE MAIN.

1. **NOTES:**  
PUMP TAP VALVES TO BE 2" FORD BRASS BALL VALVES # B11-666 W/ SCH 80 THREADED x PE NIPPLES AS REQUIRED. INLINE VALVE TO MATCH FORCE MAIN DIAMETER.
2. PROFLO BRASS SWING CHECK VALVE MODEL PROFLO PEX31 TO BE INSTALLED TO PREVENT FLOW INTO LOW PRESSURE MAIN.

LOXAHATCHEE RIVER DISTRICT

N.T.S.  
REVISION:  
DEC, 2016

IN LINE FLUSHING PORT AT FORCE MAIN

LP-25A

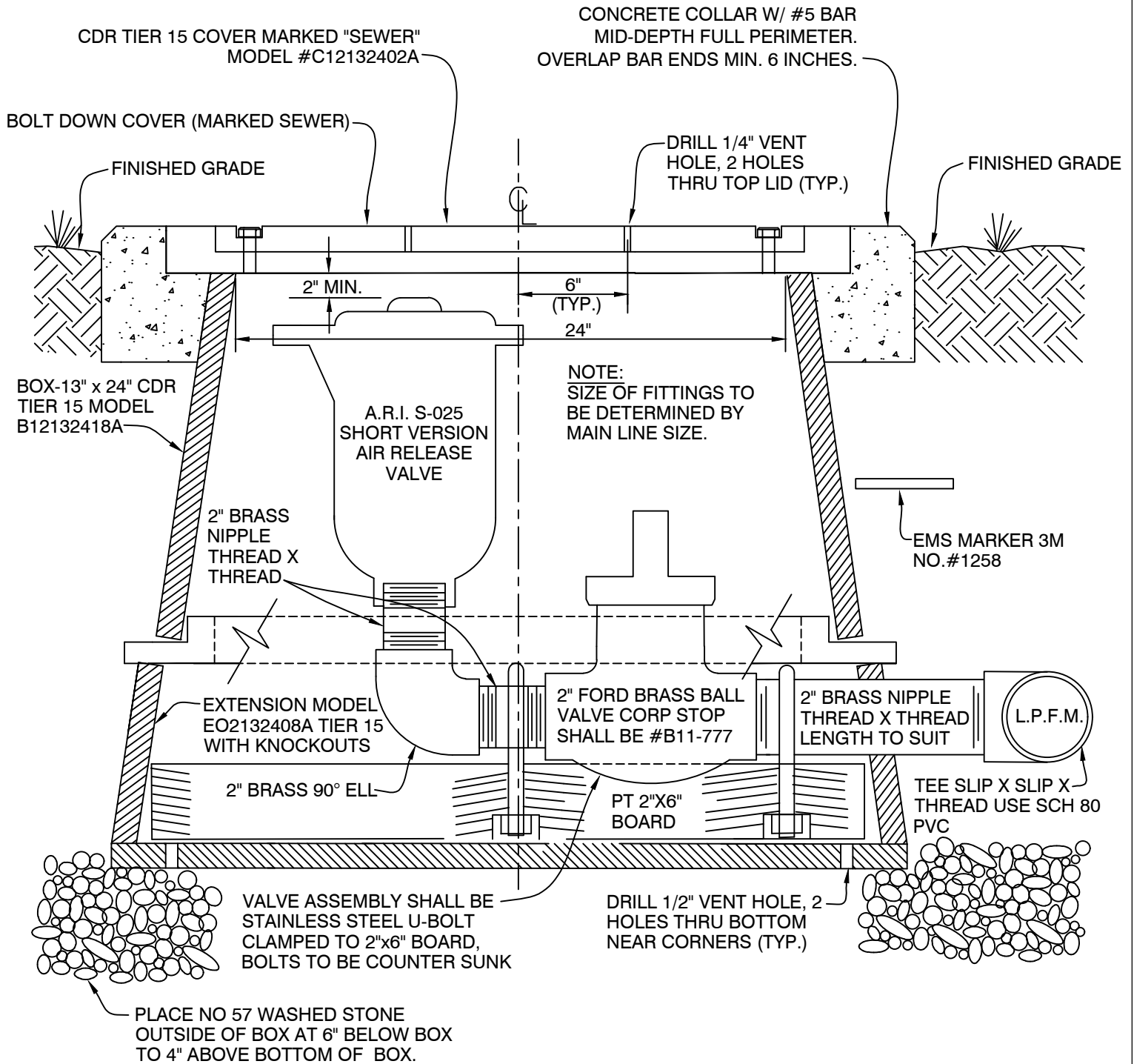

**NOTE:**

IN PAVED AREAS, USE NO. PB16"x24"x24" DEEP x 4" WALLS AND 4" FLOOR, AND NO. PB1624 TRAFFIC COVER DESIGNED FOR HS-20-44 TRAFFIC RATED BY BROOKS PRODUCTS INC.

**LOXAHATCHEE RIVER DISTRICT**

**AIR / VACUUM VALVE DETAIL**

**LP-26**

N.T.S.

REVISION:  
MARCH, 2017

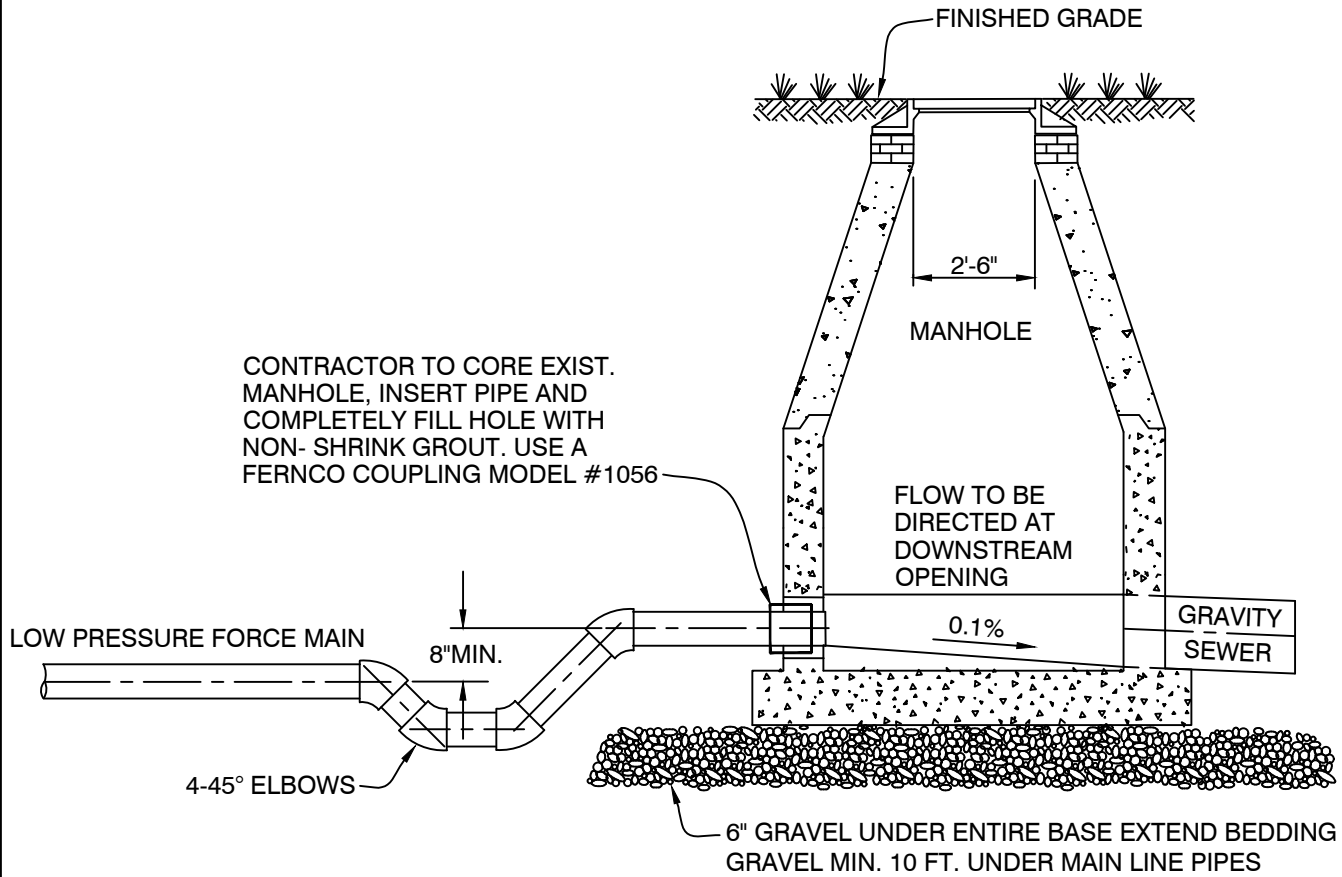

**NOTES:**

1. WHEN ELEVATION OF LOW PRESSURE MAIN (LPM) AT MANHOLE IS HIGHEST POINT OF LPM, TRAP CAN BE ELIMINATED.
2. WHEN LOW PRESSURE FORCE MAIN IS HDPE TRANSITION TO PVC FOR TRAP WITH FORD PACK JOINT COUPLING PVC x PE WITH 304SS STIFFENER.

**LOXAHATCHEE RIVER DISTRICT**

N.T.S.
REVISION:
MARCH, 2017

**LOW PRESSURE MAIN INTO SHALLOW MANHOLE**

**LP-27**

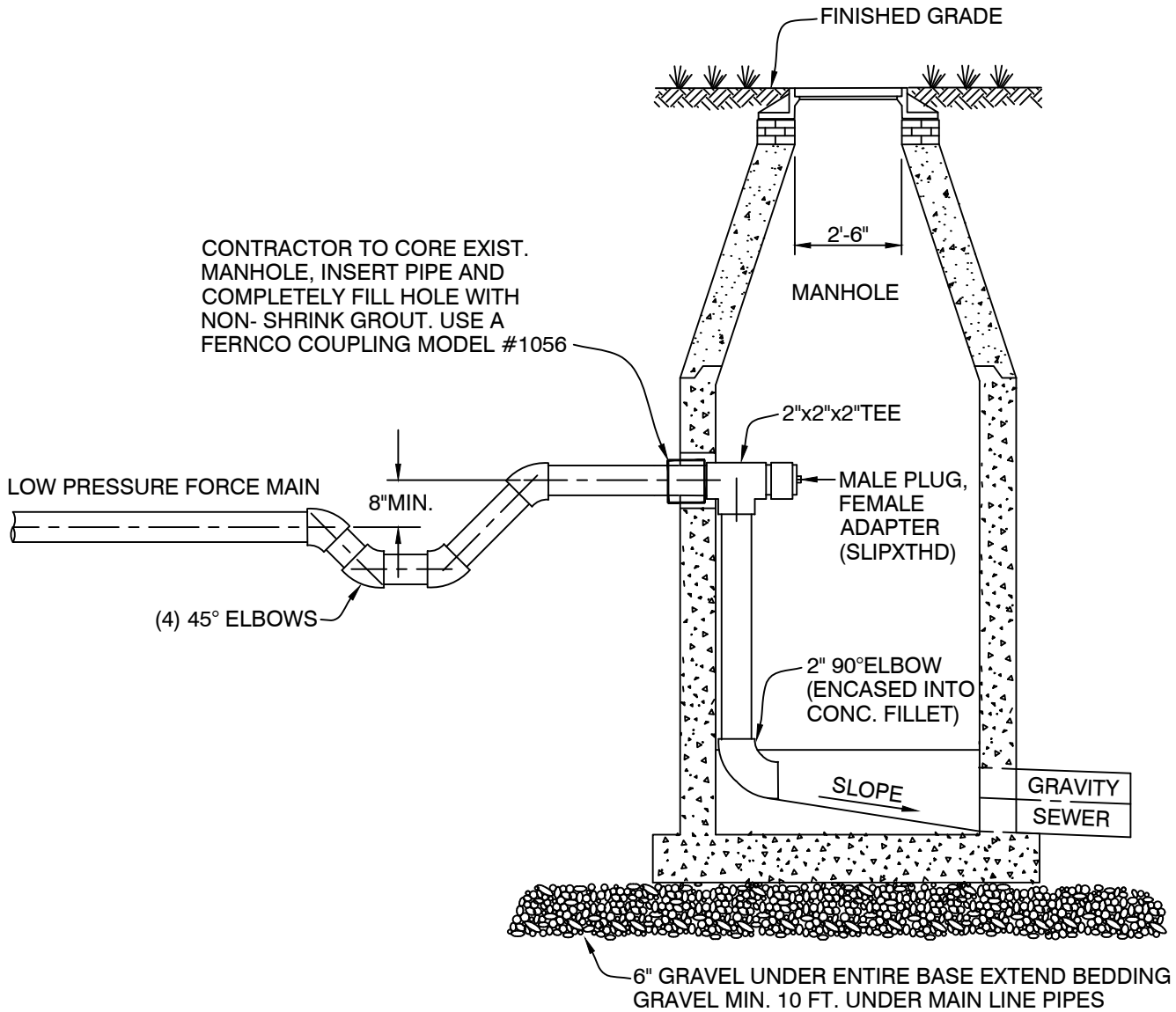

**NOTES:**

1. ALL DROP PIPING INCLUDING TEE SHALL BE SCH 40 PVC.
2. WHEN ELEVATION OF LOW PRESSURE MAIN (LPM) AT MANHOLE IS HIGHEST POINT OF LPM, TRAP CAN BE ELIMINATED.
3. WHEN LOW PRESSURE FORCE MAIN IS HDPE TRANSITION TO PVC FOR TRAP WITH FORD PACK JOINT COUPLING PVC x PE WITH 304SS STIFFENER.

**LOXAHATCHEE RIVER DISTRICT**

N.T.S.  
 REVISION:  
 MARCH, 2017

**LOW PRESSURE MAIN INTO DEEP MANHOLE**

**LP-28**

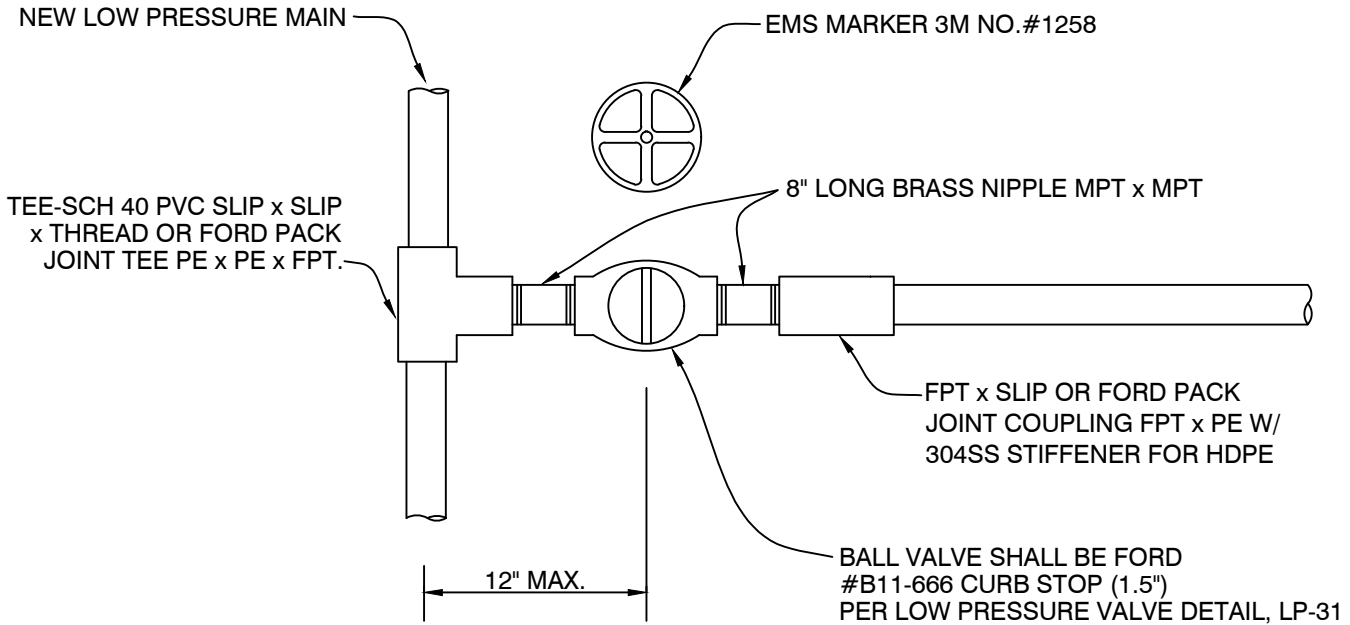

**NOTES:**

1. EMS SHALL BE INSTALLED ON STREET SIDE OF TEE AND VALVE.
2. VALVE BOX WILL BE TYLER 141Q FOR 22"-30" DEPTH OR TYLER 142R FOR 30"-42" DEPTH. (SEE DETAIL #LP-31)
3. WHEN CUTTING INTO AN EXISTING FORCE MAIN LINE USE REPAIR TYPE SCH 80 PVC SLIP OR BRASS COMPRESSION COUPLINGS IMMEDIATELY UPSTREAM OR DOWNSTREAM OF TEE.

LOXAHATCHEE RIVER DISTRICT

N.T.S.

REVISION:  
MARCH, 2017

TYPICAL ISOLATION VALVE DETAIL

LP-29

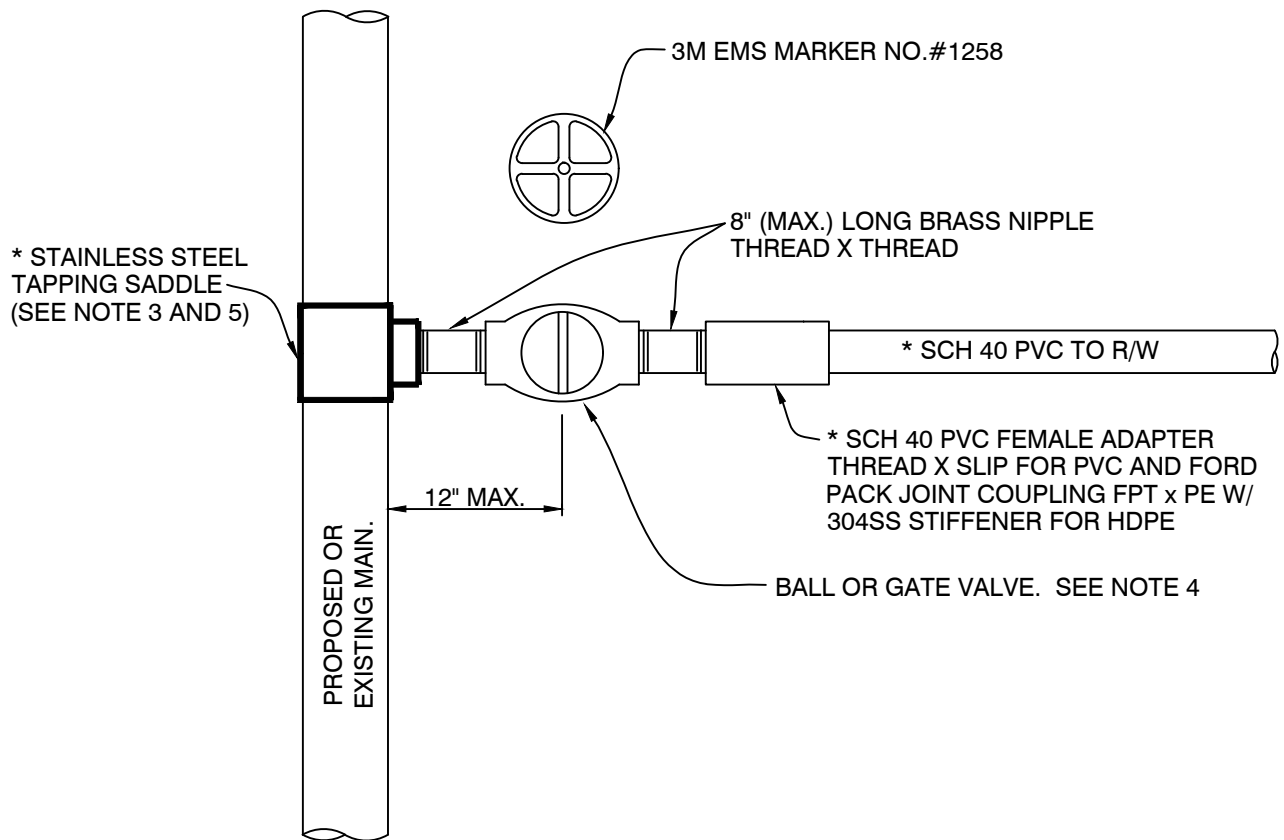

**NOTES:**

1. EMS SHALL BE INSTALLED ON STREET SIDE OF TEE AND VALVE.
2. PROVIDE VALVE BOX PER LP-31.
3. TAPPING SADDLES FOR TAPS 1-1/2" - 2-1/2" SHALL BE ROMAC MODEL 306 OR 306H. TAPPING SADDLES FOR TAPS LARGER THAN 2-1/2" SHALL COMPLY WITH SD-28
4. VALVES UP TO 2-1/2" SHALL BE FORD #B11-XXXM CURB STOP W/ 2" OPERATING NUT MODEL # QT67. 3" VALVES SHALL COMPLY W/ SECTION 130, PARAGRAPH 130.03.
5. FOR 2-1/2" AND SMALLER PVC MAINS USE SOCKET TEE AND BRASS COMPRESSION COUPLING. FOR 2-1/2" AND SMALLER HDPE MAINS USE FORD PACK JOINT TEE WITH FORD PACK JOINT COUPLING AND PVC SPOOL PIECE.

**LOXAHATCHEE RIVER DISTRICT**

**LOW PRESSURE TIE - IN DETAIL**

**LP-30**

N.T.S.

REVISION:  
MARCH, 2017

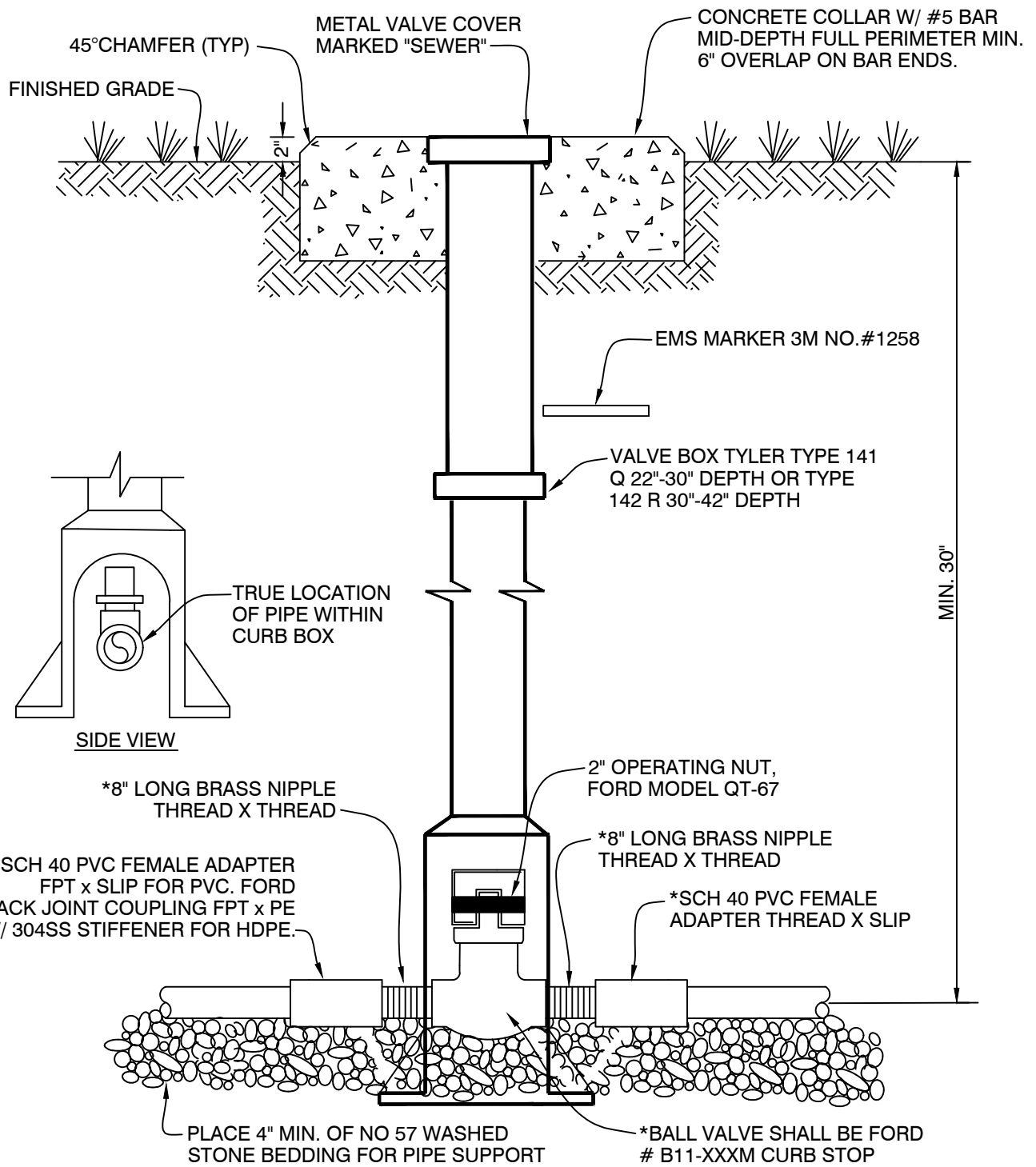

\*SIZE BY ENGINEER

LOXAHATCHEE RIVER DISTRICT

LOW PRESSURE VALVE DETAIL

LP-31

N.T.S.

REVISION:  
MARCH, 2017

REPLACEMENT PAVEMENT MUST BE TYPE S-1 ASPHALTIC CONCRETE 1-1/2" THICK HOT MIX, WITH TACK COAT. IT MUST BE ROLLED OR COMPACTED TO A SMOOTH SURFACE LEVEL WITH EXISTING ROAD SURFACE.

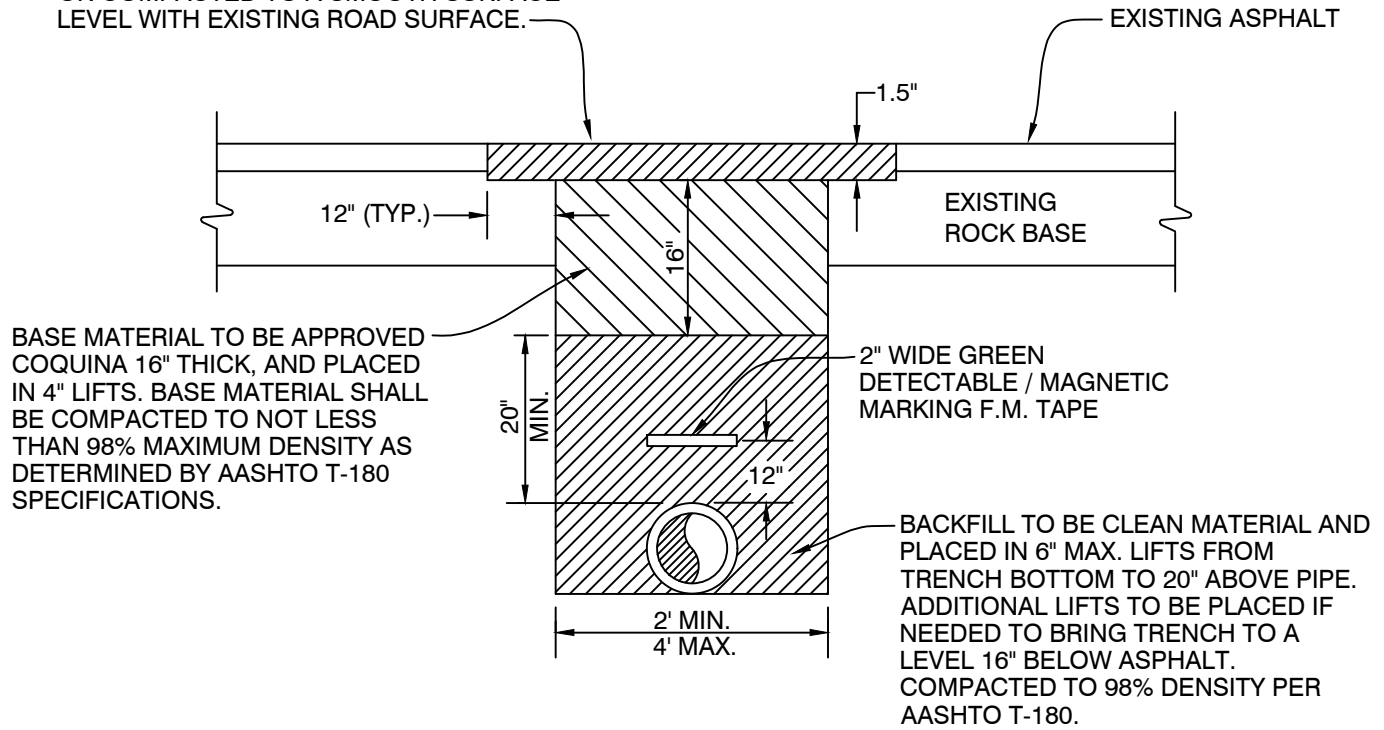

**NOTES:**

1. SAW CUT ASPHALT BEFORE EXCAVATING.
2. COMPACTION MUST BE DONE BY A MECHANICAL VIBRATORY COMPACTOR. EACH LIFT MUST RECEIVE 5 PASSES OF THE COMPACTOR OVER ENTIRE SURFACE. BEFORE COMPACTING EACH LIFT, WATER MUST BE APPLIED AT THE RATE OF 1 GAL. PER LINEAL FOOT OF THE TRENCH FOR BACKFILL AND 1/2 GAL. PER LINEAL FOOT OF TRENCH FOR COQUINA BASE. WATER TO BE SPRINKLED EVENLY OVER TRENCH WIDTH.
3. IF EXCAVATION LEAVES LESS THAN 1' OF UNDISTURBED BASE BETWEEN TRENCH AND SAW CUT ASPHALT, ADDITIONAL WIDTH OF ASPHALT MUST BE CUT.

LOXAHATCHEE RIVER DISTRICT

N.T.S.

REVISION:  
APRIL, 2012

TYPICAL ROAD CROSSING REPAIR DETAIL

LP-32



REMAINDER OF BACKFILL MAY BE PLACED BY MACHINE AND COMPACTED TO A MINIMUM OF 95% DENSITY PER AASHTO T-180, OR PER AGENCY HAVING ROW JURISDICTION

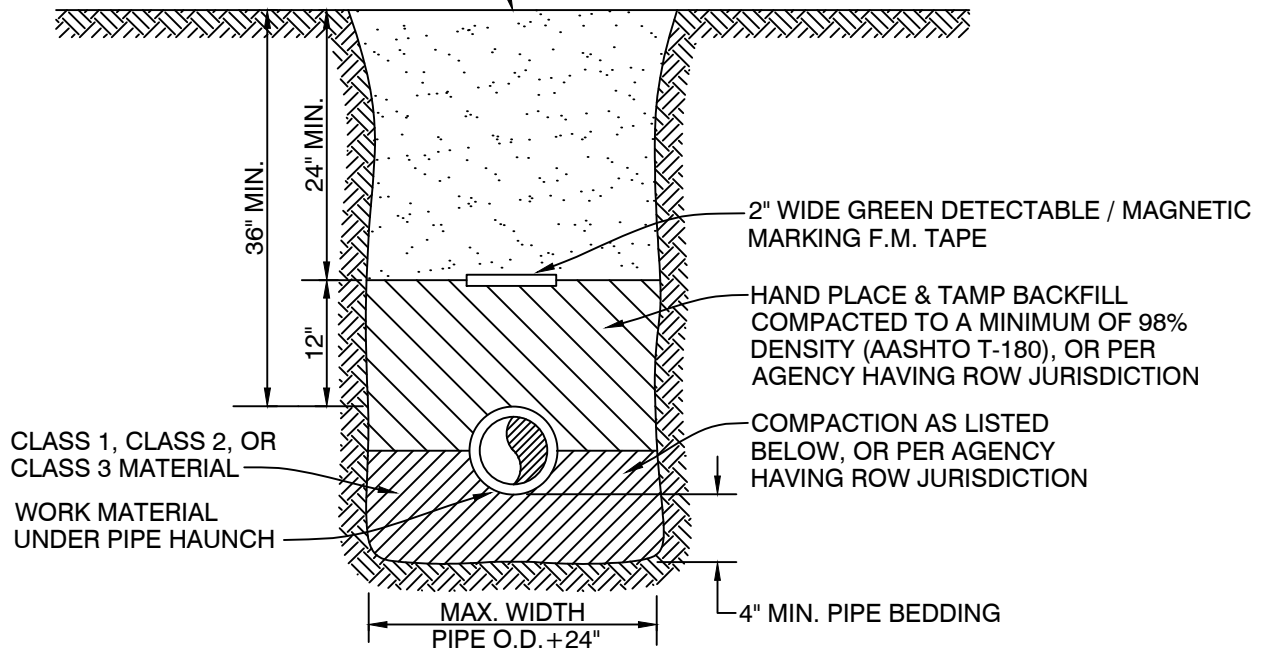

**NOTES:**

CLASS 1 MATERIAL - ANGULAR .25" TO .75" GRADED STONE SUCH AS CORAL, CRUSHED STONE, OR CRUSHED SHELLS OR BEDDING ROCK (100% PASSING 1" SIEVE).

CLASS 2 MATERIAL - COURSE SAND AND GRAVEL'S WITH MAXIMUM PARTICLE SIZE OF .25 INCH WITH SMALL PERCENTAGE OF FINES COMPACTED TO A MINIMUM OF 95% STANDARD PROCTOR DENSITY.

CLASS 3 MATERIAL - FINE SAND AND CLAYEY GRAVEL'S, INCLUDING FINE SANDS, SAND-CLAY MIXTURES AND GRAVEL-CLAY MIXTURES, COMPACTED TO A MINIMUM OF 95% STANDARD PROCTOR DENSITY. INCLUDED IN CLASS 3 ARE EXISTING SOIL TYPES CLASSIFIED AS SELECT BACKFILL.

IF CLASS 1 MATERIAL IS USED FOR BEDDING, IT MUST BE USED FOR THE ENTIRE EMBEDMENT. A DRY TRENCH SHALL BE MAINTAINED WHEN USING CLASS 2 AND CLASS 3 MATERIAL.

DENSITY TESTING IS REQUIRED IN 1 FOOT LIFTS ABOVE PIPELINE AT INTERVALS OF 400' MAXIMUM.

**LOXAHATCHEE RIVER DISTRICT**

N.T.S.  
 REVISION:  
 APRIL, 2012

**TRENCH DETAIL**

**LP-33**

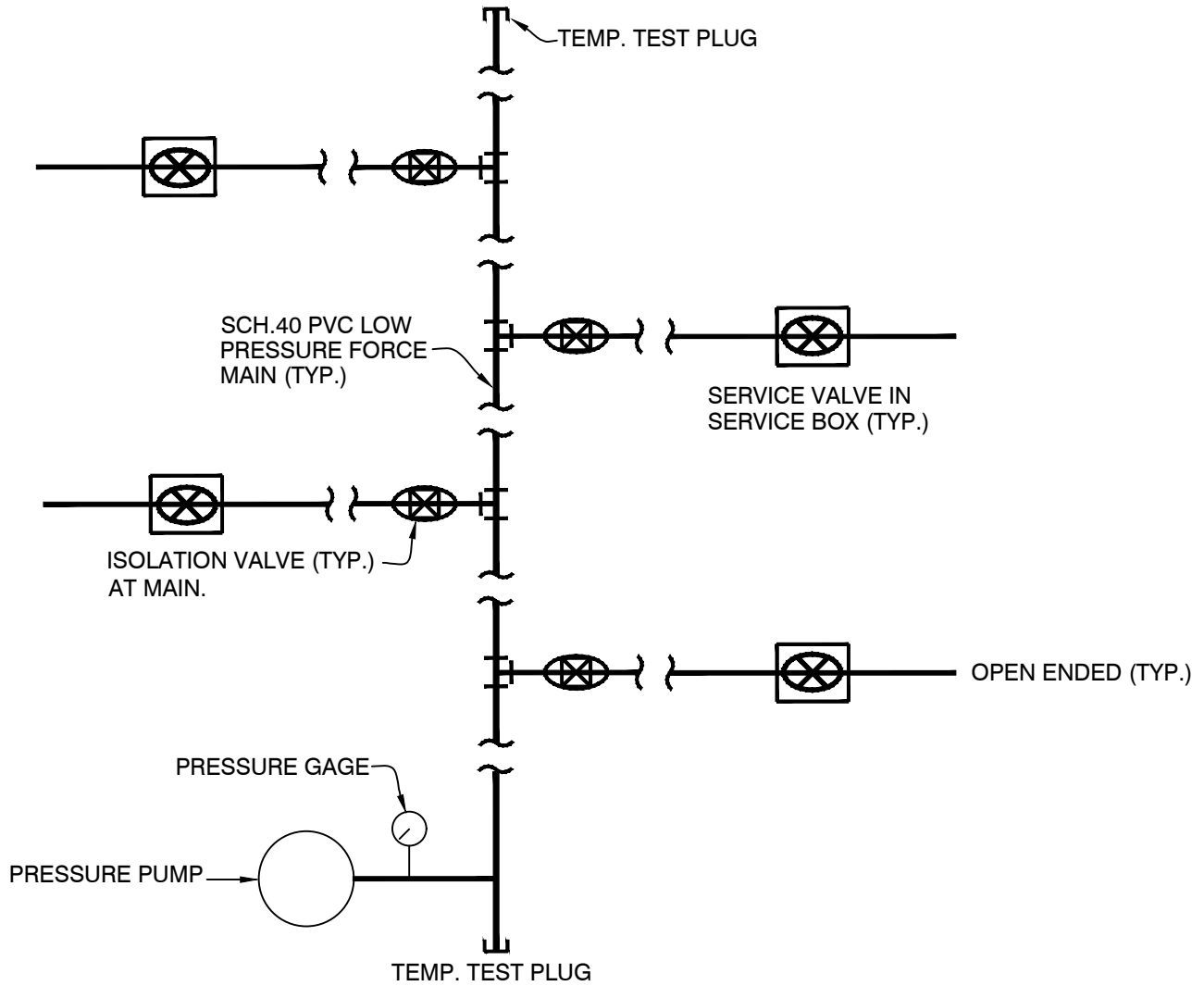

**PLAN VIEW**

**NOTES:**

1. CLOSE ALL SERVICE VALVES INSIDE SERVICE BOXES.
2. OPEN ALL ISOLATION VALVES AT MAIN.
3. PRESSURIZE SYSTEM & TEST TO 70 P.S.I. FOR ONE (1) HOUR.
4. CLOSE ISOLATION VALVES ONE AT A TIME.
5. ONE AT A TIME, OPEN SERVICE VALVE AND BLEED OFF PRESSURE AT END CAP.
6. CHECK PRESSURE.
7. IF PRESSURE DROPS, ISOLATION VALVE IS NOT HOLDING PRESSURE.
8. REPAIR OR REPLACE IF NECESSARY.
9. REPEAT STEP 5 THRU 8 FOR EACH SERVICE CONNECTION.
10. SEE LOW PRESSURE DETAILS, LP-9 & LP-10 FOR TYPICAL LAYOUTS.

LOXAHATCHEE RIVER DISTRICT

N.T.S.

REVISION:  
APRIL, 2012

TESTING PROCEDURE

LP-34

1. LOW PRESSURE PUMPING UNITS SHALL BE LOCATED SO THAT SURFACE WATER RUN OFF SHALL NOT INTERFERE WITH ELECTRICAL COMPONENTS.
2. MANUFACTURER SHALL SUPPLY AND ATTACH ELECTRICAL CONTROL PANEL SCHEMATIC TO INSIDE FACE OF CONTROL PANEL DOOR (LAMINATED).
3. THE DISTRICT WILL BE CERTIFYING ALL LOW PRESSURE LIFT STATIONS WHEN COMPLETE. MANUFACTURER SHALL SCHEDULE A START UP TEST AND SUBMIT ALL AS-BUILT DATA TO THE DISTRICT FOR CERTIFICATION.
4. LIFT STATION AND CONTROL PANEL SHALL BE LOCATED SO THAT BOTH ARE ACCESSIBLE FOR MAINTENANCE. PROVIDE A 36" CLEAR ZONE FREE FROM FENCING, LANDSCAPING AND OTHER OBSTRUCTIONS THAT MAY LIMIT ACCESS.
5. WHERE FEASIBLE, HOMEOWNER SHALL PROVIDE WATER HOSE BIB. HOSE FOR MAINTENANCE OPERATIONS.
6. AIR RELEASE VALVE AND/OR VACUUM RELIEF VALVES SHALL BE PROVIDED ON ALL LOW PRESSURE FORCE MAIN INSTALLATION IMMEDIATELY UPSTREAM OF DISCHARGE POINT TO REGIONAL GRAVITY OR FORCE MAIN SYSTEMS.
7. FORCE MAIN DETECTABLE TAPE & MAGNETIC LOCATING DEVICES WILL BE INSTALLED OVER FORCE MAIN, VALVES, AND SERVICES.

**LOXAHATCHEE RIVER DISTRICT**

N.T.S.
REVISION: JUNE, 2018

**GENERAL NOTES**

**LP-35**

- SD STANDARD DETAILS INDEX
- SD-1 TYPICAL TRENCH DETAIL FOR NON - PAVED AREAS
- SD-2 TYPICAL TRENCH & PAVEMENT RESTORATION DETAIL
- SD-3 TYPICAL TRENCH & PAVEMENT RESTORATION W/ FLOWABLE FILL DETAIL
- SD-4 TYPICAL GRAVITY SEWER EMBEDMENT DETAIL
- SD-5 GREASE INTERCEPTOR DETAIL
- SD-6 4" OR 6" SINGLE SERVICE CONNECTION DETAIL
- SD-7 4" OR 6" SINGLE SERVICE CONNECTION ALTERNATE CONFIGURATION DETAIL
- SD-8 6" DOUBLE SERVICE CONNECTION DETAIL
- SD-9 6" DOUBLE SERVICE CONNECTION ALTERNATE CONFIGURATION DETAIL
- SD-10 SANITARY SEWER LATERAL CLEAN OUT PROTECTIVE BOX (PAVED AREAS ONLY) DETAIL
- SD-11 PRECAST MANHOLE DETAIL
- SD-12 GRAVITY SEWER INSIDE DROP MANHOLE DETAIL
- SD-13 MANHOLE FRAME AND COVER DETAIL
- SD-14 MANHOLE EXTENSION RING DETAIL
- SD-15 DOGHOUSE MANHOLE INSTALLATION INTO AN EXISTING GRAVITY SEWER LINE DETAIL
- SD-16 SEWER MANHOLE INSTALLATION INTO AN EXISTING GRAVITY SEWER LINE DETAIL
- SD-17 SEWER MAIN / STORM DRAIN CONFLICT STRUCTURE DETAIL
- SD-18 FORCE MAIN THRUST RESTRAINT CHART
- SD-19 FORCE MAIN THRUST RESTRAINT DETAIL
- SD-20 FORCE MAIN TERMINAL END DETAIL
- SD-21 FORCE MAIN INTO SHALLOW MANHOLE DETAIL
- SD-22 FORCE MAIN INTO DEEP MANHOLE DETAIL
- SD-23 AUTOMATIC AIR RELEASE VALVE OFFSET FORCE MAIN CONDITION DETAIL
- SD-24 AUTOMATIC AIR RELEASE VALVE DETAIL
- SD-25 TYPICAL FORCE MAIN AIR RELEASE VALVE DETAIL ALTERNATE OFFSET CONFIGURATION
- SD-26 FORCE MAIN DRAIN DETAIL
- SD-27 BURIED VALVE DETAIL
- SD-28 TAPPING FORCE MAIN DETAIL
- SD-29 RECORD DRAWING SUBMITTAL GUIDE
- SD-30 STANDARD WATER AND SEWER SEPARATION STATEMENT
- SD-31 LIFT STATION STRUCTURAL & MECHANICAL STANDARD DETAILS
- SD-32 LIFT STATION ELECTRICAL CONTROL PANEL STANDARD DETAILS
- SD-33 LIFT STATION ELECTRICAL CONTROL PANEL STANDARD DETAILS
- SD-34 LIFT STATION ELECTRICAL CONTROL PANEL STANDARD DETAILS

**LOXAHATCHEE RIVER DISTRICT**

N.T.S.	<b>STANDARD DETAILS INDEX</b>	<b>SD</b>
REVISION: JAN, 2016		

REMAINDER OF BACKFILL MAY BE PLACED BY MACHINE AND COMPACTED TO A MINIMUM OF 95% DENSITY PER AASHTO T-180 (12" MAX. LIFTS), OR PER AGENCY HAVING JURISDICTION.

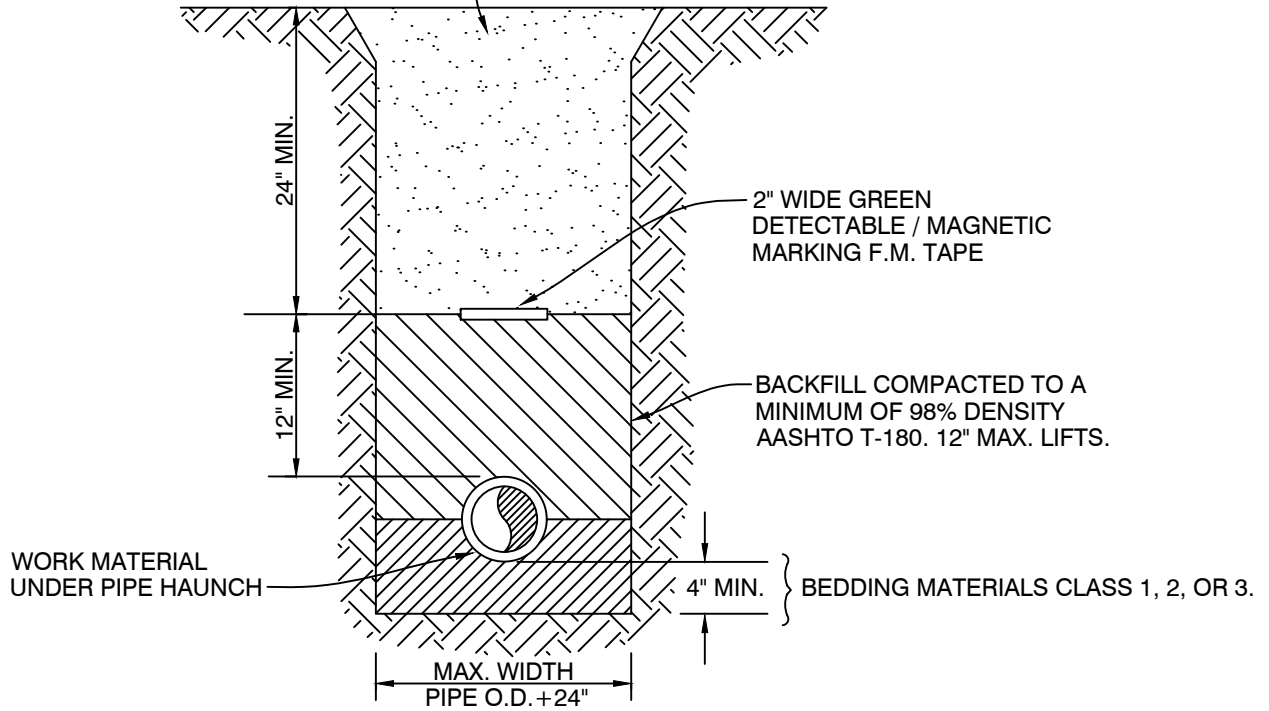

**NOTES:**

CLASS 1 MATERIAL - ANGULAR .25" TO .75" GRADED STONE SUCH AS CORAL, CRUSHED STONE, OR CRUSHED SHELLS OR BEDDING ROCK (100% PASSING 1" SIEVE).

CLASS 2 MATERIAL - COURSE SAND AND GRAVEL'S WITH MAXIMUM PARTICLE SIZE OF .25 INCH WITH SMALL PERCENTAGE OF FINES. COMPACT TO A MIN. 98% DENSITY PER AASHTO T-180.

CLASS 3 MATERIAL - FINE SAND AND CLAYEY GRAVEL'S, INCLUDING FINE SANDS, SAND-CLAY MIXTURES AND GRAVEL-CLAY MIXTURES. INCLUDED IN CLASS 3 ARE EXISTING SOIL TYPES CLASSIFIED AS SELECT BACKFILL. COMPACT TO A MIN. 98% DENSITY PER AASHTO T-180.

1. IF CLASS 1 MATERIAL IS USED FOR BEDDING, IT MUST BE USED FOR THE ENTIRE EMBEDMENT. A DRY TRENCH SHALL BE MAINTAINED WHEN USING CLASS 2 AND CLASS 3 MATERIAL.
2. DENSITY TESTING IS REQUIRED IN 1 FOOT LIFTS ABOVE PIPELINE AT INTERVALS OF 400' MAXIMUM.
3. UNSUITABLE IN-SITU MATERIAL SUCH AS MUCK, DEBRIS AND LARGER ROCKS SHALL BE REMOVED.
4. THE AFFECTED AREA SHALL BE RESTORED TO EQUAL OR BETTER CONDITION OR AS SPECIFIED IN PERMIT / CONTRACT DOCUMENTS.

**LOXAHATCHEE RIVER DISTRICT**

**TYPICAL TRENCH DETAIL  
FOR NON - PAVED AREAS**

N.T.S.

REVISION:  
APRIL, 2012

**SD-1**

REPLACEMENT PAVEMENT (OVERLAY) MUST BE TYPE S-1 (MOD.) OR S-3 ASPHALTIC CONCRETE HOT MIX, WITH TACK COAT. IT MUST BE ROLLED OR COMPACTED TO A SMOOTH SURFACE LEVEL WITH EXISTING ROAD SURFACE.

BASE MATERIAL TO BE APPROVED COQUINA OR APPROVED CRUSHED CONCRETE\*, A MIN. OF 16" THICK, AND PLACED IN 4" LIFTS. BASE MATERIAL SHALL BE COMPACTED TO NOT LESS THAN 98% MAXIMUM DENSITY AS DETERMINED BY AASHTO T-180 SPECIFICATIONS.

\*CRUSHED CONCRETE 97% PASSING 3" SIEVE NOT MORE THAN 20% PASSING #200 SIEVE LBR > 100 CONTAIN 60% CARBONATES.

WORK MATERIAL UNDER PIPE HAUNCH

CUT BACK 1.5' EACH SIDE, FROM EXISTING ASPHALT (SAW CUT LINE)

NEW OVERLAY (AS REQUIRED)

EXISTING ASPHALT

EXISTING ROCK BASE

2" WIDE GREEN DETECTABLE / MAGNETIC MARKING F.M. TAPE

BACKFILL COMPACTED TO A MINIMUM OF 98% DENSITY AASHTO T-180. 8" MAX. LIFTS.

BEDDING MATERIALS CLASS 1, 2, OR 3.

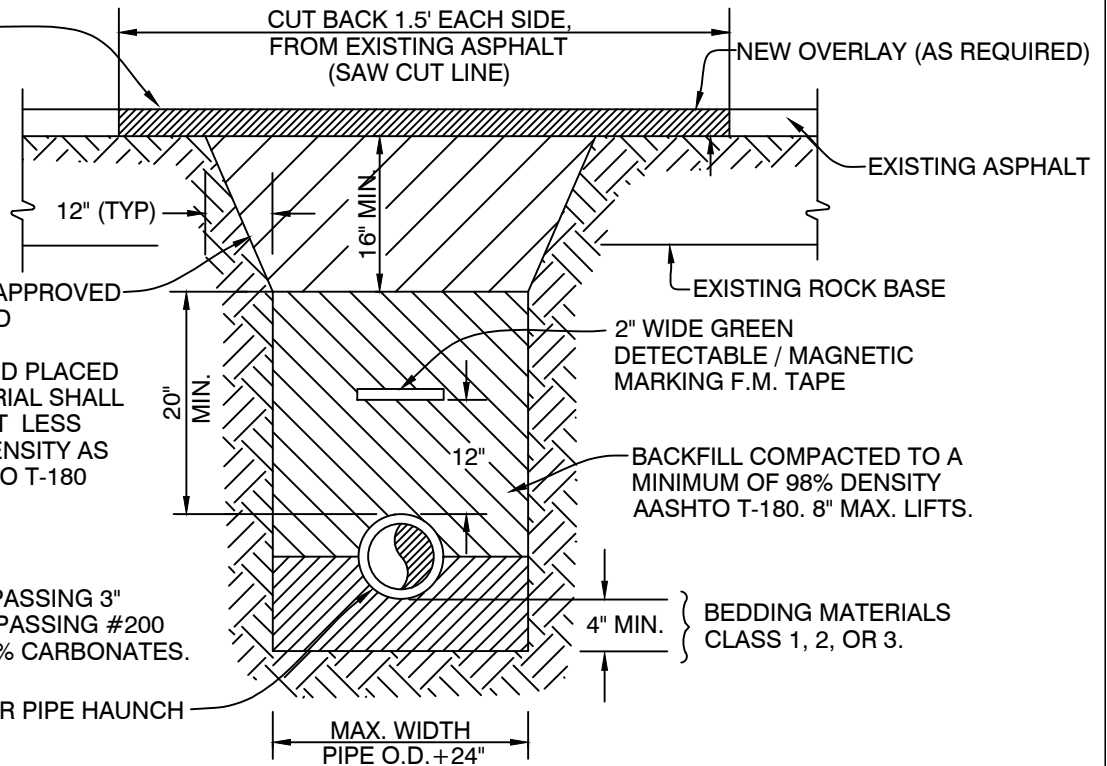

**NOTES:**

CLASS 1 MATERIAL - ANGULAR .25" TO .75" GRADED STONE SUCH AS CORAL, CRUSHED STONE, OR CRUSHED SHELLS OR BEDDING ROCK (100% PASSING 1" SIEVE).

CLASS 2 MATERIAL - COURSE SAND AND GRAVEL'S WITH MAXIMUM PARTICLE SIZE OF .25 INCH WITH SMALL PERCENTAGE OF FINES. COMPACT TO A MIN. 98% DENSITY PER AASHTO T-180.

CLASS 3 MATERIAL - FINE SAND AND CLAYEY GRAVEL'S, INCLUDING FINE SANDS, SAND-CLAY MIXTURES AND GRAVEL-CLAY MIXTURES. INCLUDED IN CLASS 3 ARE EXISTING SOIL TYPES CLASSIFIED AS SELECT BACKFILL. COMPACT TO A MIN. 98% DENSITY PER AASHTO T-180.

1. ALL CUTS WILL REQUIRE COMPACTION TO DENSITY SPECIFICATIONS.
2. SAW CUT ASPHALT BEFORE EXCAVATING.
3. COMPACTION MUST BE DONE BY A MECHANICAL VIBRATORY COMPACTOR. EACH LIFT MUST RECEIVE 5 PASSES OF THE COMPACTOR OVER ENTIRE SURFACE. BEFORE COMPACTING EACH LIFT, WATER MUST BE APPLIED AT THE RATE OF 1 GAL. PER LINEAL FOOT OF THE TRENCH FOR BACKFILL AND 0.5 GAL. PER LINEAL FOOT OF TRENCH FOR COQUINA BASE. WATER TO BE SPRINKLED EVENLY OVER TRENCH WIDTH.
4. UNSUITABLE IN-SITU MATERIAL SUCH AS MUCK, DEBRIS AND LARGER ROCKS SHALL BE REMOVED.
5. THE AFFECTED AREA SHALL BE RESTORED TO EQUAL OR BETTER CONDITION OR AS SPECIFIED IN PERMIT / CONTRACT DOCUMENTS.

**LOXAHATCHEE RIVER DISTRICT**

**TYPICAL TRENCH & PAVEMENT RESTORATION DETAIL**

N.T.S.

REVISION:  
APRIL, 2012

**SD-2**

REPLACEMENT PAVEMENT (OVERLAY) MUST BE TYPE S-1 (MOD.) OR S-3 ASPHALTIC CONCRETE HOT MIX, WITH TACK COAT. IT MUST BE ROLLED OR COMPACTED TO A SMOOTH SURFACE LEVEL WITH EXISTING ROAD SURFACE.

BASE MATERIAL TO BE EXCAVATABLE FLOWABLE FILL PER FLORIDA D.O.T. SECTION 121, W/ ACCELERATOR TO OBTAIN 75% MAX. STRENGTH IN 4-6 HOURS.

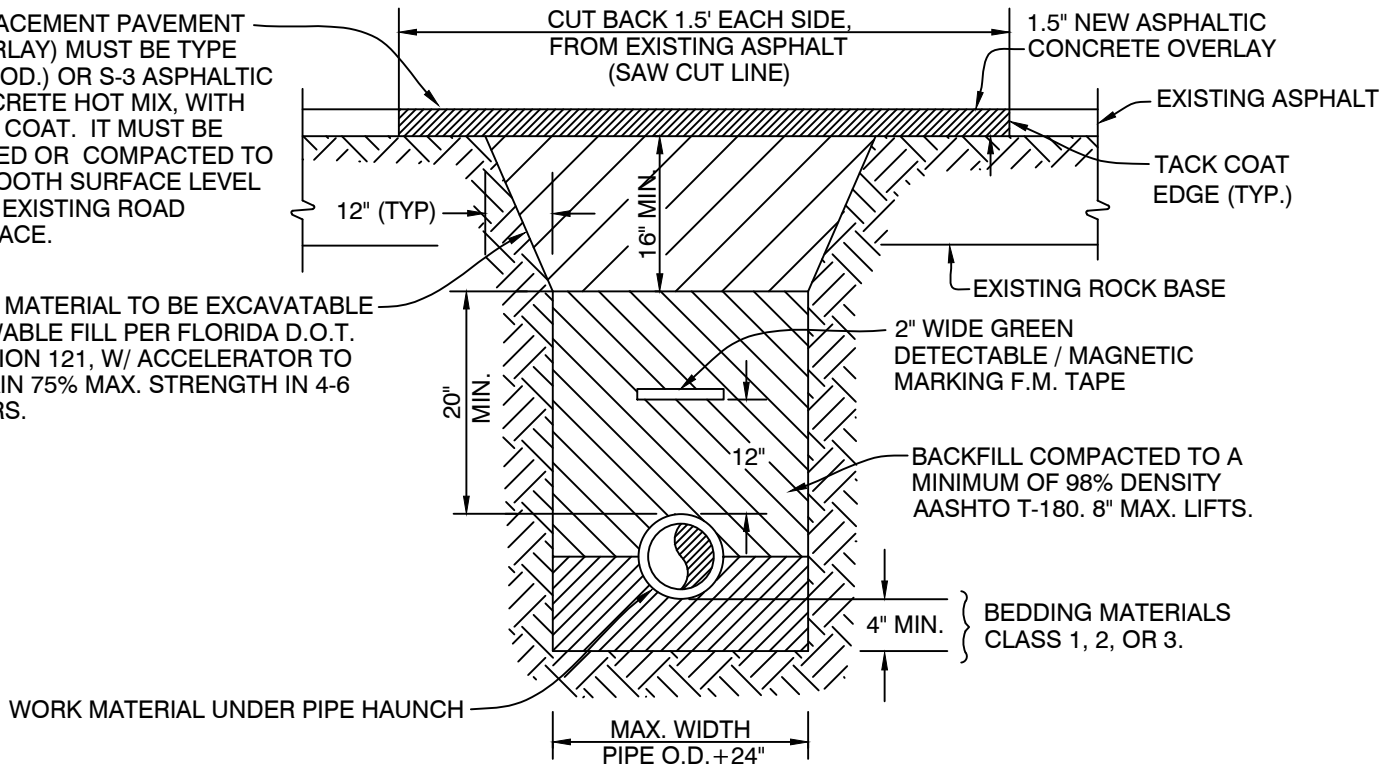

**NOTES:**

CLASS 1 MATERIAL - ANGULAR .25" TO .75" GRADED STONE SUCH AS CORAL, CRUSHED STONE, OR CRUSHED SHELLS OR BEDDING ROCK (100% PASSING 1" SIEVE).

CLASS 2 MATERIAL - COURSE SAND AND GRAVEL'S WITH MAXIMUM PARTICLE SIZE OF .25 INCH WITH SMALL PERCENTAGE OF FINES. COMPACT TO A MIN. 98% DENSITY PER AASHTO T-180.

CLASS 3 MATERIAL - FINE SAND AND CLAYEY GRAVEL'S, INCLUDING FINE SANDS, SAND-CLAY MIXTURES AND GRAVEL-CLAY MIXTURES. INCLUDED IN CLASS 3 ARE EXISTING SOIL TYPES CLASSIFIED AS SELECT BACKFILL. COMPACT TO A MIN. 98% DENSITY PER AASHTO T-180.

1. ALL CUTS WILL REQUIRE COMPACTION TO DENSITY SPECIFICATIONS.
2. SAW CUT ASPHALT BEFORE EXCAVATING.
3. COMPACTION MUST BE DONE BY A MECHANICAL VIBRATORY COMPACTOR. EACH LIFT MUST RECEIVE 5 PASSES OF THE COMPACTOR OVER ENTIRE SURFACE. BEFORE COMPACTION EACH LIFT, WATER MUST BE APPLIED AT THE RATE OF 1 GAL. PER LINEAL FOOT OF THE TRENCH FOR BACKFILL AND 0.5 GAL. PER LINEAL FOOT OF TRENCH FOR COQUINA BASE. WATER TO BE SPRINKLED EVENLY OVER TRENCH WIDTH.
4. UNSUITABLE IN-SITU MATERIAL SUCH AS MUCK, DEBRIS AND LARGER ROCKS SHALL BE REMOVED.
5. THE AFFECTED AREA SHALL BE RESTORED TO EQUAL OR BETTER CONDITION OR AS SPECIFIED IN PERMIT / CONTRACT DOCUMENTS.

**LOXAHATCHEE RIVER DISTRICT**

N.T.S.  
REVISION:  
APRIL, 2012

**TYPICAL TRENCH & PAVEMENT RESTORATION  
W/ FLOWABLE FILL DETAIL**

**SD-3**

REMAINDER OF BACKFILL MAY BE PLACED BY MACHINE AND COMPACTED TO A MINIMUM OF 95% DENSITY PER AASHTO T-180 (12" MAX. LIFTS), OR PER AGENCY HAVING JURISDICTION.

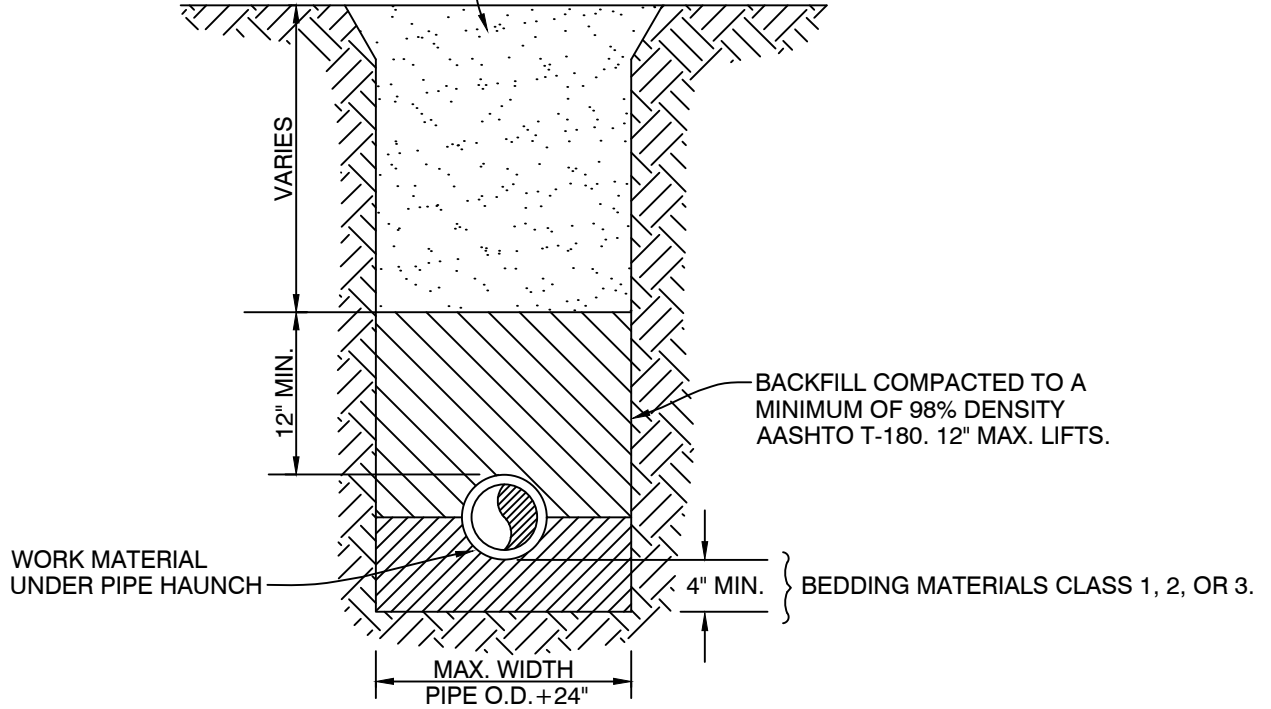

**NOTES:**

CLASS 1 MATERIAL - ANGULAR .25" TO .75" GRADED STONE SUCH AS CORAL, CRUSHED STONE, OR CRUSHED SHELLS OR BEDDING ROCK (100% PASSING 1" SIEVE).

CLASS 2 MATERIAL - COURSE SAND AND GRAVEL'S WITH MAXIMUM PARTICLE SIZE OF .25 INCH WITH SMALL PERCENTAGE OF FINES. COMPACT TO A MIN. 98% DENSITY PER AASHTO T-180.

CLASS 3 MATERIAL - FINE SAND AND CLAYEY GRAVEL'S, INCLUDING FINE SANDS, SAND-CLAY MIXTURES AND GRAVEL-CLAY MIXTURES. INCLUDED IN CLASS 3 ARE EXISTING SOIL TYPES CLASSIFIED AS SELECT BACKFILL. COMPACT TO A MIN. 98% DENSITY PER AASHTO T-180.

1. IF CLASS 1 MATERIAL IS USED FOR BEDDING, IT MUST BE USED FOR THE ENTIRE EMBEDMENT. A DRY TRENCH SHALL BE MAINTAINED WHEN USING CLASS 2 AND CLASS 3 MATERIAL.
2. DENSITY TESTING IS REQUIRED IN 1 FOOT LIFTS ABOVE PIPELINE.
3. UNSUITABLE IN-SITU MATERIAL SUCH AS MUCK, DEBRIS AND LARGER ROCKS SHALL BE REMOVED.
4. THE AFFECTED AREA SHALL BE RESTORED TO EQUAL OR BETTER CONDITION OR AS SPECIFIED IN PERMIT / CONTRACT DOCUMENTS.

**LOXAHATCHEE RIVER DISTRICT**

N.T.S.  
REVISION:  
APRIL, 2012

**TYPICAL GRAVITY SEWER EMBEDMENT DETAIL**

**SD-4**



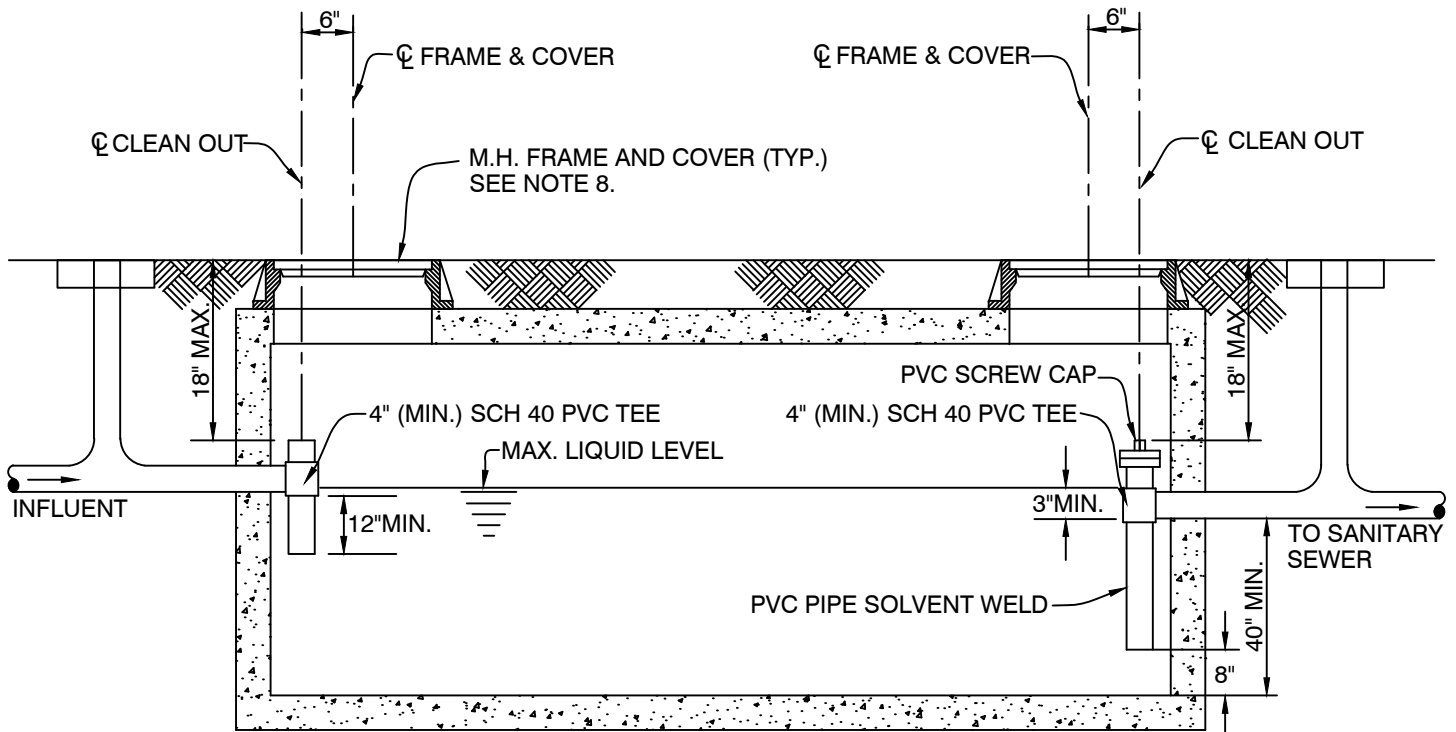

**NOTES:**

1. EFFECTIVE SIZE OF INTERCEPTOR 750 GALS MIN. AND SHALL BE MADE OF CONCRETE.
2. TANK TO BE DESIGNED TO RESIST FLOTATION WHEN EMPTY.
3. TWO-WAY CLEAN OUTS WILL BE INSTALLED IMMEDIATELY UPSTREAM AND DOWNSTREAM OF ALL GREASE INTERCEPTORS. IF INSTALLED IN PAVED AREAS, A PROTECTIVE STANDARD CLEAN OUT COVER WILL BE INSTALLED PER SD-10.
4. TANK(S) SIZING SHALL FOLLOW 2010 FL. BLDG CODE TABLE 1003.5.1. TANK CONSTRUCTION SHALL BE IN ACCORDANCE WITH CHAPTER 64E-6, OF THE FLORIDA ADMINISTRATIVE CODE.
5. ALL MATERIALS SHALL BE NEW AND CODE APPROVED.
6. ALL MANHOLE COVERS USED SHALL BE MARKED WITH: "GREASE TRAP" LETTERING.
7. TANKS TO BE IN SERIES WHERE MULTIPLE UNITS ARE REQUIRED.
8. FOR TANKS UP TO 1,250 GALLONS, USE 24" STANDARD M.H. FRAME AND COVER, U.S. FOUNDRY. FOR LARGER TANKS, USE DOUBLE RING AND COVER TYPE, #230-AB-M, U.S. FOUNDRY.

**LOXAHATCHEE RIVER DISTRICT**

N.T.S.	<b>GREASE INTERCEPTOR DETAIL</b>	<b>SD-5</b>
REVISION: APRIL, 2012		

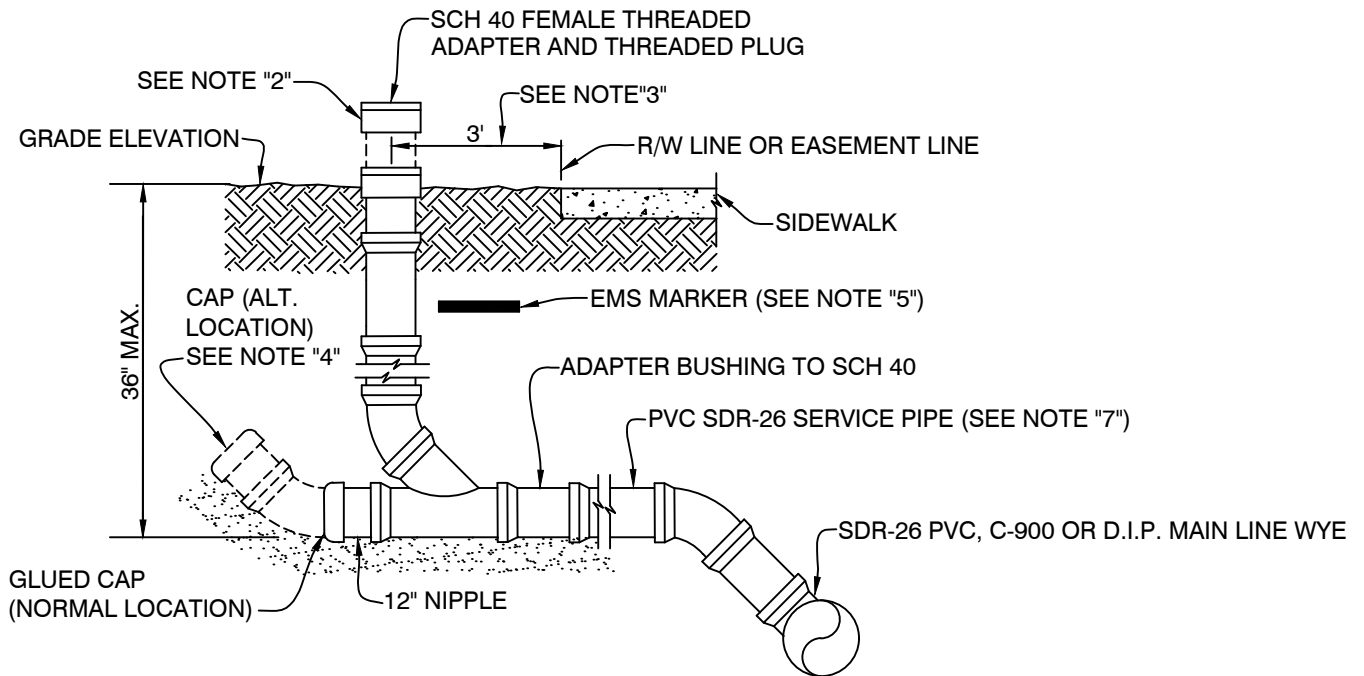

**NOTES:**

1. WHERE SEWER LATERALS MAY BE FORCED TO BE INSTALLED AT A DEPTH GREATER THAN 36" DUE TO CONFLICT WITH OTHER UTILITIES, THE WYE FITTING MAY BE PLACED IN A VERTICAL POSITION ON THE CLEAN-OUT RISER PIPE (MAX.36")
2. LEAVE RISER 18" (MIN.) ABOVE GRADE. WHEN HOUSE RISER CONNECTION IS MADE BY BUILDING PLUMBER, RISER PIPE WILL BE CUT OFF, AND SET 2" ABOVE SOD GRADE (ADAPTER SHALL BE LEFT UNGLUED).
3. IN AREAS WHERE NO SIDEWALK EXISTS OR WHERE NONE ARE PLANNED, THE CLEAN OUT RISER WILL BE SET AT R/W OR EASEMENT LINE.
4. IN AREAS WHERE GROUND WATER TABLE IS LESS THAN 36" FROM FINISHED GRADE, NIPPLE OUT OF WYE WILL BE EXTENDED UP TO A POINT 6" MIN. ABOVE GROUND WATER TABLE.
5. EMS MARKER MODEL NO.1258, SERVICE LINE ELECTRONIC MARKER AS MFG. BY 3M CO., TO REMAIN IN PLACE AFTER CONNECTION OF BUILDING SEWER. BURY IN FRONT OF CLEAN OUT RISER 18" BELOW FINISHED GRADE.
6. 6" SINGLE SERVICES USED ONLY FOR COMMERCIAL OR MULTI-FAMILY RESIDENTIAL UNITS.
7. WHEN MAIN LINE IS C-900 PVC OR DIP (EPOXY COATED), SERVICE PIPE SHALL BE SAME MATERIAL AS MAIN LINE.
8. WHEN APPROVED BY THE DISTRICT, CLEAN-OUTS MAY BE PLACED IN PAVED AREAS, HOWEVER, PROTECTIVE BOXES AS SHOWN ON DETAIL SD-1 MUST BE INSTALLED.

**(PLUMBERS ONLY)**

WHERE EXISTING SERVICE LATERAL IS VITRIFIED CLAY PIPE, BELL (HUB) WILL BE REMOVED WITH APPROVED SAW AND A "FERNCO" VCP X PVC COUPLING WILL BE USED TO JOIN THE EXISTING AND NEW PIPE. FERNCO COUPLING WILL BE WRAPPED IN STRANDS OF COPPER WIRE AND COUPLING WILL BE BEDDED IN TYPE "57" ROCK TO UNDISTURBED MATERIAL. WHERE EXISTING SERVICE LATERAL IS DIP OR C-900, A DISTRICT APPROVED PVC TRANSITION COUPLING WILL BE USED.

**LOXAHATCHEE RIVER DISTRICT**

N.T.S. REVISION: APRIL, 2012	<b>4" OR 6" SINGLE SERVICE CONNECTION          DETAIL</b>	<b>SD-6</b>
------------------------------------	---	-------------

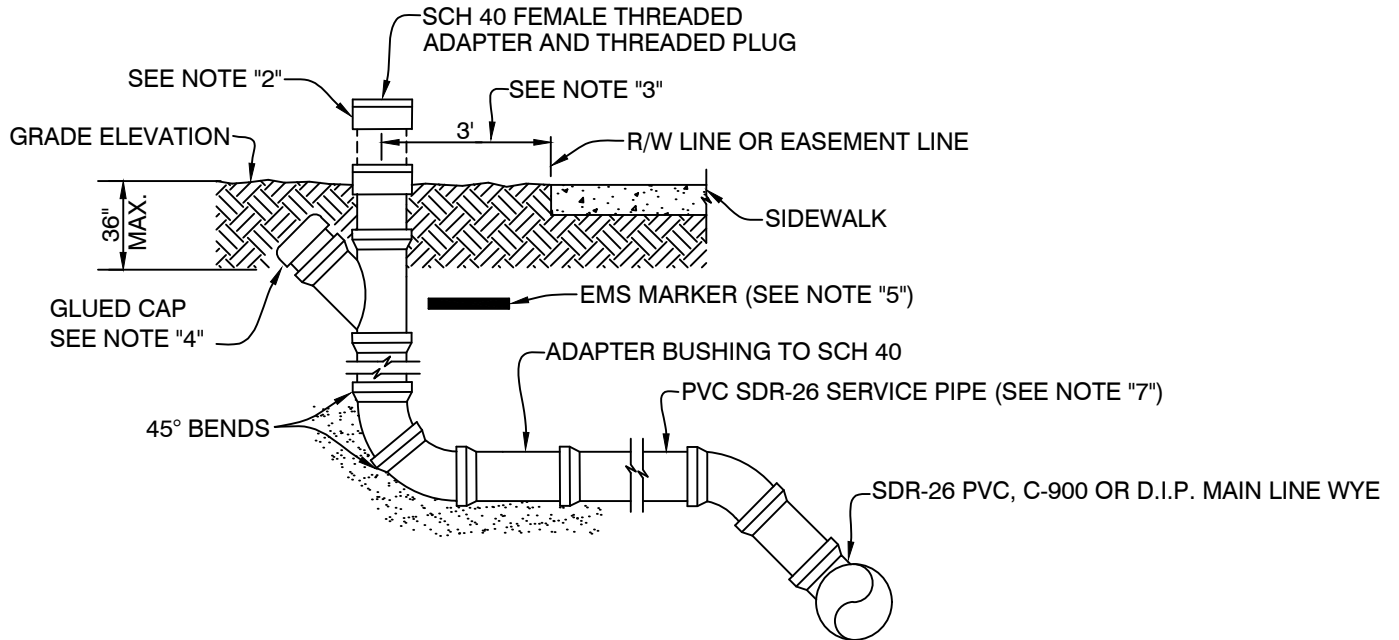

**NOTES:**

1. WHERE SEWER LATERALS MAY BE FORCED TO BE INSTALLED AT A DEPTH GREATER THAN 36" DUE TO CONFLICT WITH OTHER UTILITIES, THE WYE FITTING MAY BE PLACED IN A VERTICAL POSITION ON THE CLEAN-OUT RISER PIPE (MAX.36")
2. LEAVE RISER 18" (MIN.) ABOVE GRADE. WHEN HOUSE RISER CONNECTION IS MADE BY BUILDING PLUMBER, RISER PIPE WILL BE CUT OFF, AND SET 2" ABOVE SOD GRADE (ADAPTER SHALL BE LEFT UNGLUED).
3. IN AREAS WHERE NO SIDEWALK EXISTS OR WHERE NONE ARE PLANNED, THE CLEAN OUT RISER WILL BE SET AT R/W OR EASEMENT LINE.
4. IN AREAS WHERE GROUND WATER TABLE IS LESS THAN 36" FROM FINISHED GRADE, NIPPLE OUT OF WYE WILL BE EXTENDED UP TO A POINT 6" MIN. ABOVE GROUND WATER TABLE.
5. EMS MARKER MODEL NO.1258, SERVICE LINE ELECTRONIC MARKER AS MFG. BY 3M CO., TO REMAIN IN PLACE AFTER CONNECTION OF BUILDING SEWER. BURY IN FRONT OF CLEAN OUT RISER 18" BELOW FINISHED GRADE.
6. 6" SINGLE SERVICES USED ONLY FOR COMMERCIAL OR MULTI-FAMILY RESIDENTIAL UNITS.
7. WHEN MAIN LINE IS C-900 PVC OR DIP (EPOXY COATED), SERVICE PIPE SHALL BE SAME MATERIAL AS MAIN LINE.
8. WHEN APPROVED BY THE DISTRICT, CLEAN-OUTS MAY BE PLACED IN PAVED AREAS, HOWEVER, PROTECTIVE BOXES AS SHOWN ON DETAIL SD-1 MUST BE INSTALLED.

**(PLUMBERS ONLY)**

WHERE EXISTING SERVICE LATERAL IS VITRIFIED CLAY PIPE, BELL (HUB) WILL BE REMOVED WITH APPROVED SAW AND A "FERNCO" VCP X PVC COUPLING WILL BE USED TO JOIN THE EXISTING AND NEW PIPE. FERNCO COUPLING WILL BE WRAPPED IN STRANDS OF COPPER WIRE AND COUPLING WILL BE BEDDED IN TYPE "57" ROCK TO UNDISTURBED MATERIAL. WHERE EXISTING SERVICE LATERAL IS DIP OR C-900, A DISTRICT APPROVED PVC TRANSITION COUPLING WILL BE USED.

**LOXAHATCHEE RIVER DISTRICT**

N.T.S.	<b>4" OR 6" SINGLE SERVICE CONNECTION ALTERNATE CONFIGURATION DETAIL</b>	<b>SD-7</b>
REVISION: APRIL, 2012		

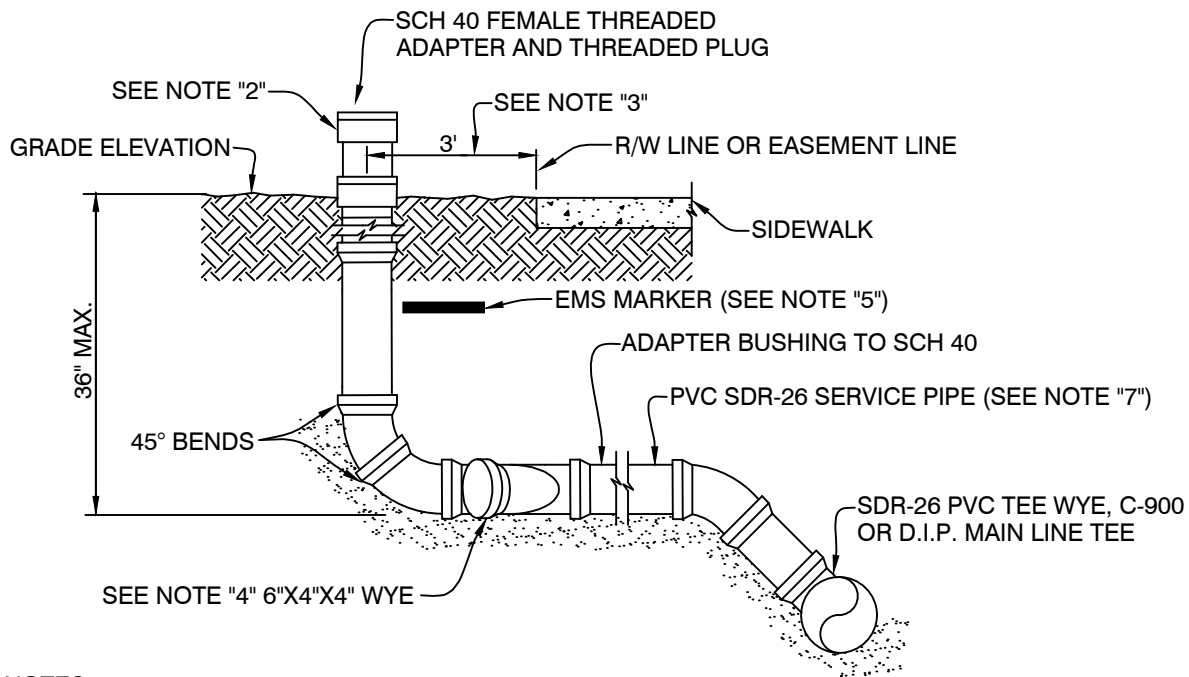

**NOTES:**

1. WHERE SEWER LATERALS MAY BE FORCED TO BE INSTALLED AT A DEPTH GREATER THAN 36" DUE TO CONFLICT WITH OTHER UTILITIES, THE WYE FITTING MAY BE PLACED IN A VERTICAL POSITION ON THE CLEAN-OUT RISER PIPE (ALTERNATE CONFIGURATION)
2. LEAVE RISER 18" (MIN.) ABOVE GRADE. WHEN HOUSE RISER CONNECTION IS MADE BY BUILDING PLUMBER, RISER PIPE WILL BE CUT OFF, AND SET 2" ABOVE SOD GRADE (ADAPTER SHALL BE LEFT UNGLUED).
3. IN AREAS WHERE NO SIDEWALK EXISTS OR WHERE NONE ARE PLANNED, THE CLEAN OUT RISER WILL BE SET AT R/W OR EASEMENT LINE.
4. IN AREAS WHERE GROUND WATER TABLE IS LESS THAN 36" FROM FINISHED GRADE, NIPPLES OUT OF WYE WILL BE EXTENDED UP TO A POINT 6" MIN. ABOVE GROUND WATER TABLE.
5. EMS MARKER MODEL NO.1258, SERVICE LINE ELECTRONIC MARKER AS MFG. BY 3M CO., TO REMAIN IN PLACE AFTER CONNECTION OF BUILDING SEWER. BURY IN FRONT OF CLEAN OUT RISER 18" BELOW FINISHED GRADE.
6. 6" SINGLE SERVICES USED ONLY FOR COMMERCIAL OR MULTI-FAMILY RESIDENTIAL UNITS. (SEE SD-3 & SD-4)
7. WHEN MAIN LINE IS C-900 PVC OR EPOXY COATED DIP, SERVICE PIPE SHALL BE SAME MATERIAL AS MAIN LINE.
8. WHEN APPROVED BY THE DISTRICT, CLEAN-OUTS MAY BE PLACED IN PAVED AREAS, HOWEVER, PROTECTIVE BOXES AS SHOWN ON DETAIL SD-1 MUST BE INSTALLED.

(PLUMBERS ONLY)

WHERE EXISTING SERVICE LATERAL IS VITRIFIED CLAY PIPE, BELL (HUB) WILL BE REMOVED WITH APPROVED SAW AND A "FERNCO" VCP X PVC COUPLING WILL BE USED TO JOIN THE EXISTING AND NEW PIPE. FERNCO COUPLING WILL BE WRAPPED IN STRANDS OF COPPER WIRE AND COUPLING WILL BE BEDDED IN TYPE "57" ROCK. WHERE EXISTING SERVICE LATERAL IS DIP OR C-900, A DISTRICT APPROVED PVC TRANSITION COUPLING WILL BE USED.

**LOXAHATCHEE RIVER DISTRICT**

N.T.S.	<b>6" DOUBLE SERVICE CONNECTION DETAIL</b>	<b>SD-8</b>
REVISION: APRIL, 2012		

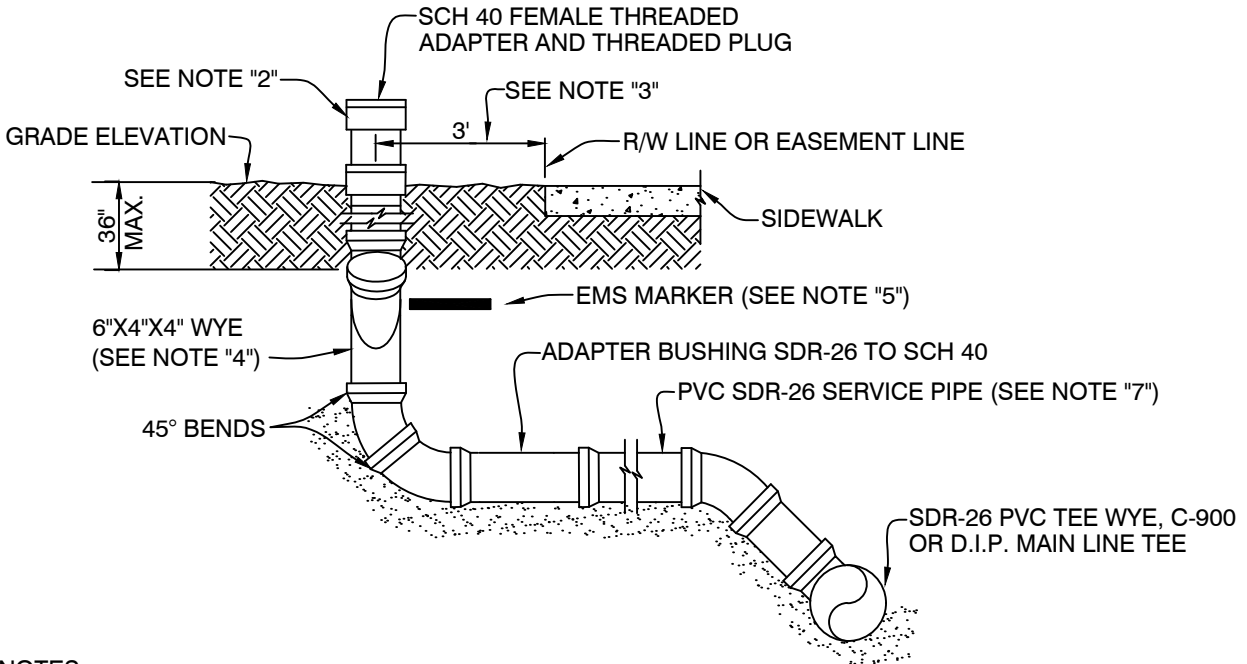

**NOTES:**

1. WHERE SEWER LATERALS MAY BE FORCED TO BE INSTALLED AT A DEPTH GREATER THAN 36" DUE TO CONFLICT WITH OTHER UTILITIES, THE WYE FITTING MAY BE PLACED IN A VERTICAL POSITION ON THE CLEAN-OUT RISER PIPE (ALTERNATE CONFIGURATION)
2. LEAVE RISER 18" (MIN.) ABOVE GRADE. WHEN HOUSE RISER CONNECTION IS MADE BY BUILDING PLUMBER, RISER PIPE WILL BE CUT OFF, AND SET 2" ABOVE SOD GRADE (ADAPTER SHALL BE LEFT UNGLUED).
3. IN AREAS WHERE NO SIDEWALK EXISTS OR WHERE NONE ARE PLANNED, THE CLEAN OUT RISER WILL BE SET AT R/W OR EASEMENT LINE.
4. IN AREAS WHERE GROUND WATER TABLE IS LESS THAN 36" FROM FINISHED GRADE, NIPPLES OUT OF WYE WILL BE EXTENDED UP TO A POINT 6" MIN. ABOVE GROUND WATER TABLE.
5. EMS MARKER MODEL NO.1258, SERVICE LINE ELECTRONIC MARKER AS MFG. BY 3M CO., TO REMAIN IN PLACE AFTER CONNECTION OF BUILDING SEWER. BURY IN FRONT OF CLEAN OUT RISER 18" BELOW FINISHED GRADE.
6. 6" SINGLE SERVICES USED ONLY FOR COMMERCIAL OR MULTI-FAMILY RESIDENTIAL UNITS. (SEE SD-3 & SD-4)
7. WHEN MAIN LINE IS C-900 PVC OR EPOXY COATED DIP, SERVICE PIPE SHALL BE SAME MATERIAL AS MAIN LINE.
8. WHEN APPROVED BY THE DISTRICT, CLEAN-OUTS MAY BE PLACED IN PAVED AREAS, HOWEVER, PROTECTIVE BOXES AS SHOWN ON DETAIL SD-1 MUST BE INSTALLED.

**(PLUMBERS ONLY)**

WHERE EXISTING SERVICE LATERAL IS VITRIFIED CLAY PIPE, BELL (HUB) WILL BE REMOVED WITH APPROVED SAW AND A "FERNCO" VCP X PVC COUPLING WILL BE USED TO JOIN THE EXISTING AND NEW PIPE. FERNCO COUPLING WILL BE WRAPPED IN STRANDS OF COPPER WIRE AND COUPLING WILL BE BEDDED IN TYPE "57" ROCK. WHERE EXISTING SERVICE LATERAL IS DIP OR C-900, A DISTRICT APPROVED PVC TRANSITION COUPLING WILL BE USED.

**LOXAHATCHEE RIVER DISTRICT**

N.T.S. REVISION: APRIL, 2012	<h2 style="margin: 0;">6" DOUBLE SERVICE CONNECTION ALTERNATE CONFIGURATION DETAIL</h2>	<h2 style="margin: 0;">SD-9</h2>
------------------------------------	---	----------------------------------

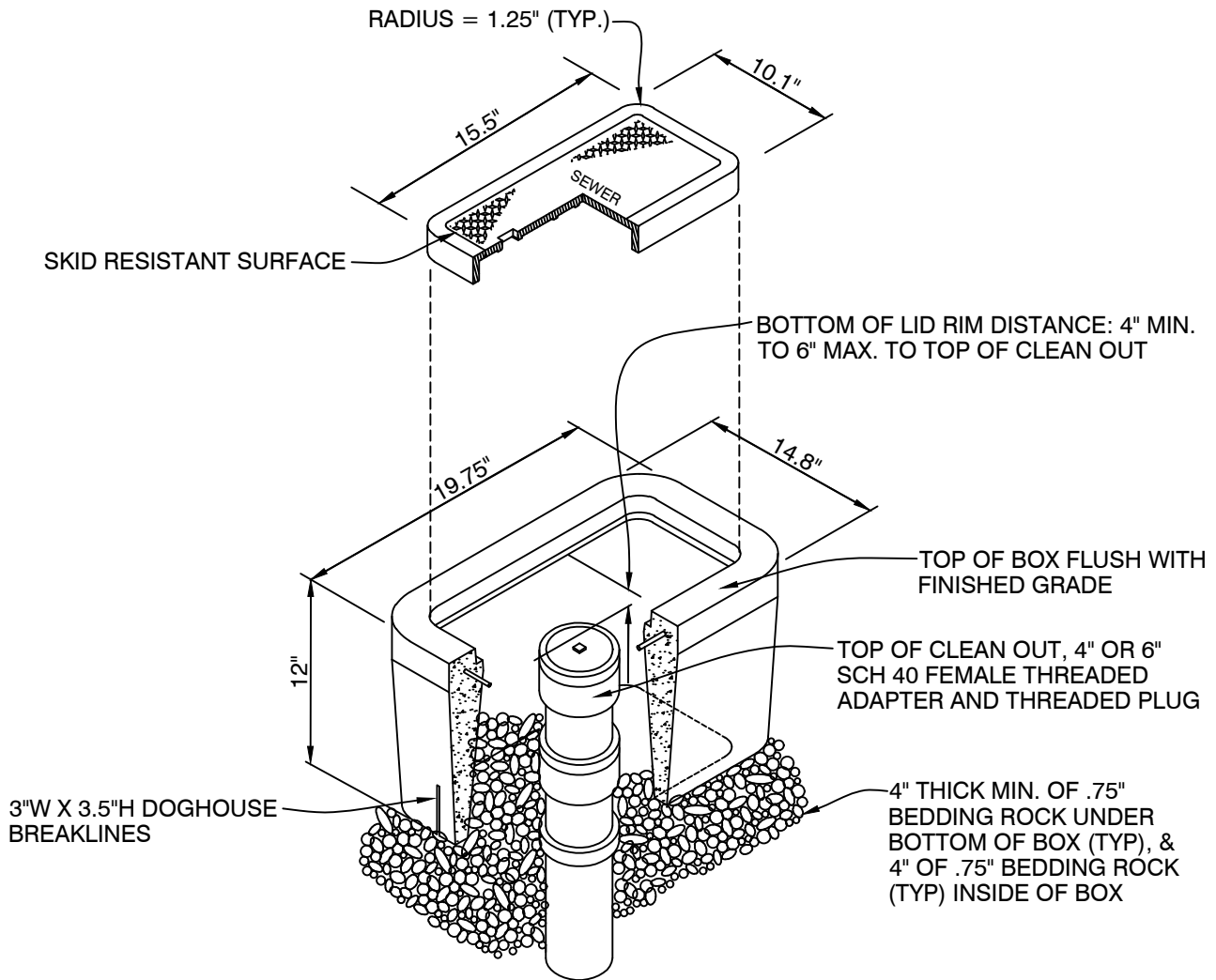

NOTES:

1. STANDARD COVER MARKED WITH "SEWER".
2. CONCRETE: MIN. 28 DAY CONCRETE COMPRESSIVE STRENGTH = 4,500 PSI.
3. REINFORCING TO BE #6 GAGE WELDED WIRE FABRIC.
4. CLEAN OUT BOX, PLACED ON CRUSHED AGGREGATE.
5. ALL DIMENSIONS ARE APPROXIMATE.
6. LID & BOX MFG. BY BROOKS PRODUCTS SERIES 36 TYPE OR APPROVED EQUAL. (LID: NO. 36-T CAST IRON HEAVY DUTY COVER WT:18LBS, BOX: NO 36 BODY WT:92LBS.)

LOXAHATCHEE RIVER DISTRICT

N.T.S.  
REVISION:  
APRIL, 2012

SANITARY SEWER LATERAL CLEAN OUT  
PROTECTIVE BOX (PAVED AREAS ONLY) DETAIL

SD-10

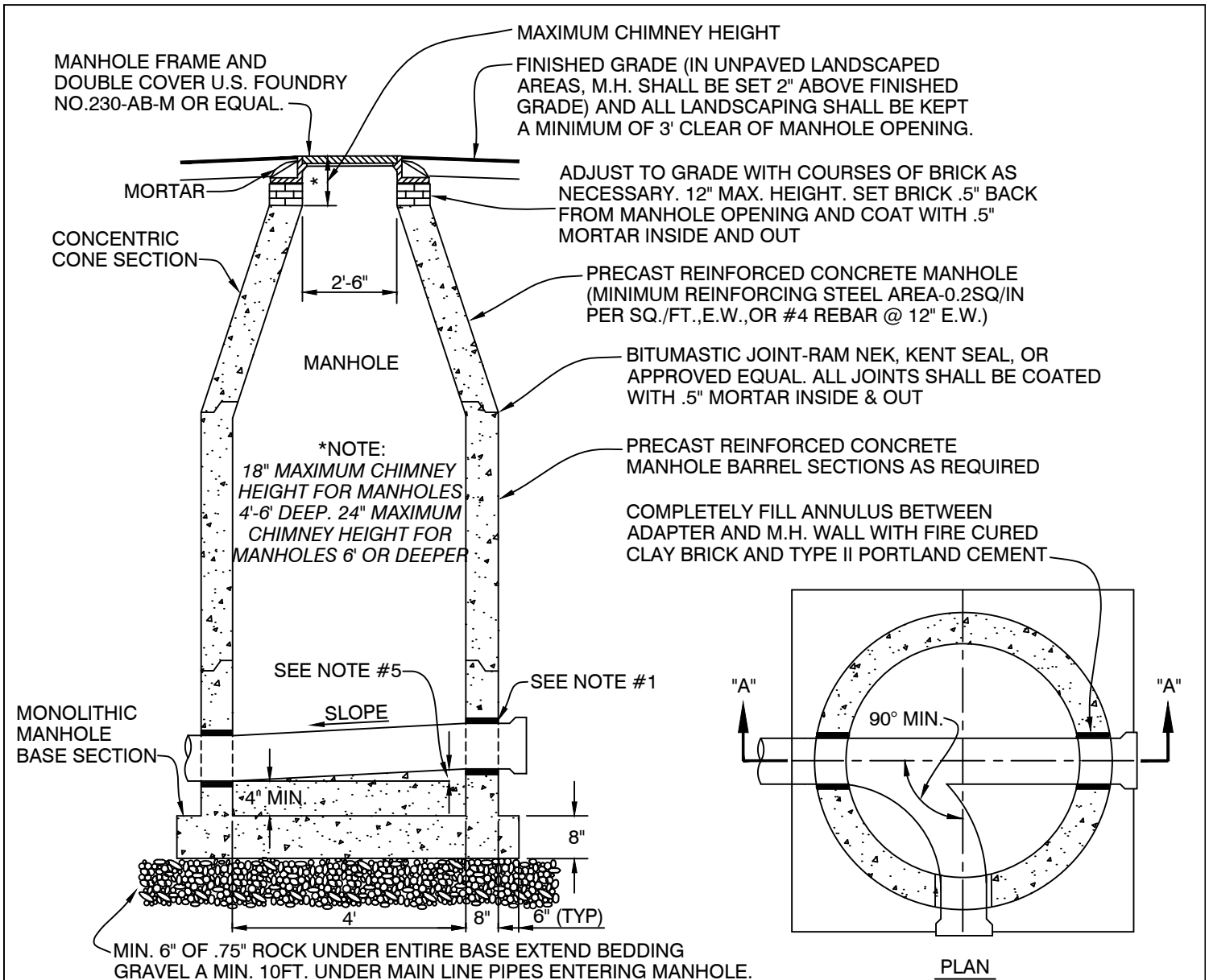

**NOTES:**

**SECTION "A-A"**

1. WHEN THE MAIN LINE IS PVC, A DISTRICT APPROVED HEAVY AGGREGATE COATED PVC M.H. ADAPTER (HARCO OR EQUAL) OR FERNCO M.H. ADAPTER SHALL BE USED. CAST IN PLACE RUBBER BOOTS WITH STAINLESS STEEL HARDWARE (CAST-A-SEAL 12-08 FOR 8", Z-LOC C-107 FOR ALL OTHER SIZES) MAY BE USED AS AN ALTERNATE.
2. CHANNEL WIDTHS AND INVERT RADII VARY UNIFORMLY FROM END TO END.
3. ALL HOLES FOR PIPES SHALL BE CAST INTO THE MANHOLES. OPENINGS REQUIRED ON ALL EXISTING MANHOLES SHALL BE CORED WITH APPROVED MACHINES.
4. WHEN INVERT DIFFERENTIALS BETWEEN PIPES ENTERING MANHOLES IS 2'. OR LESS, A "SLIDE" TYPE FLOW CHANNEL SHALL BE CONSTRUCTED TO FORM A SMOOTH FLOW TRANSITION. WHEN TWO (2) OR MORE "SLIDES" HAVE AN INVERT DIFFERENTIAL OF GREATER THAN .5' AND LESS THAN 2'. THE MANHOLE SHALL BE 5'-0". ALL INSIDE DROP MANHOLE'S SHALL BE 5' I.D. (SEE DETAIL SD-12).
5. A MINIMUM DIFFERENTIAL OF .1' SHALL BE PROVIDED BETWEEN THE INLET AND OUTLET PIPE INVERTS.
6. ALL MANHOLES 14' OR MORE FROM RIM TO LOWEST INVERT, SHALL RECEIVE A MINIMUM 0.5" THICK COATING OF SEWPERCOAT OR APPROVED EQUAL.
7. ALL MANHOLES IN A WELL FIELD PROTECTION ZONE 1 OR 2, SHALL RECEIVE A MINIMUM 1" THICK COATING OF SEWPERCOAT OR APPROVED EQUAL.

**LOXAHATCHEE RIVER DISTRICT**

N.T.S.	<b>PRECAST MANHOLE DETAIL</b>	<b>SD-11</b>
REVISION: MARCH, 2017		

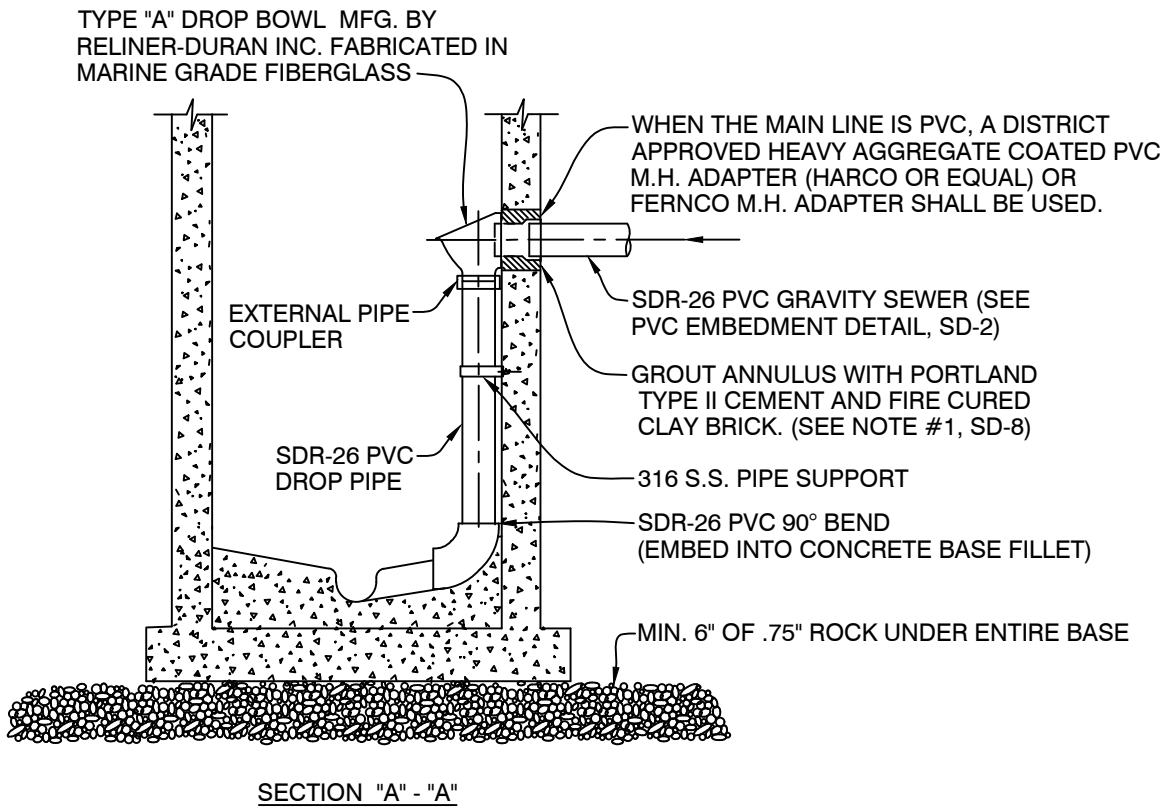
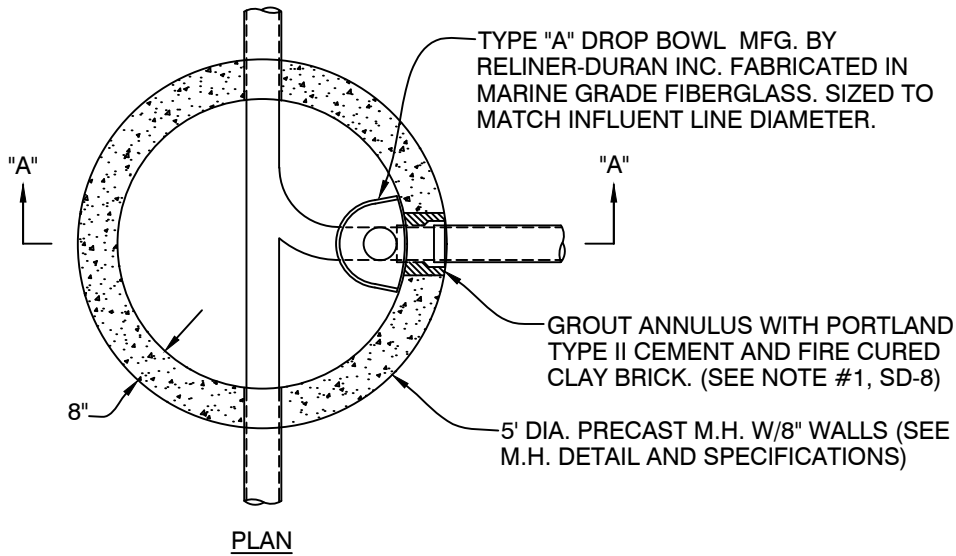

LOXAHATCHEE RIVER DISTRICT

N.T.S.  
 REVISION:  
 APRIL, 2012

GRAVITY SEWER  
 INSIDE DROP MANHOLE DETAIL

SD-12



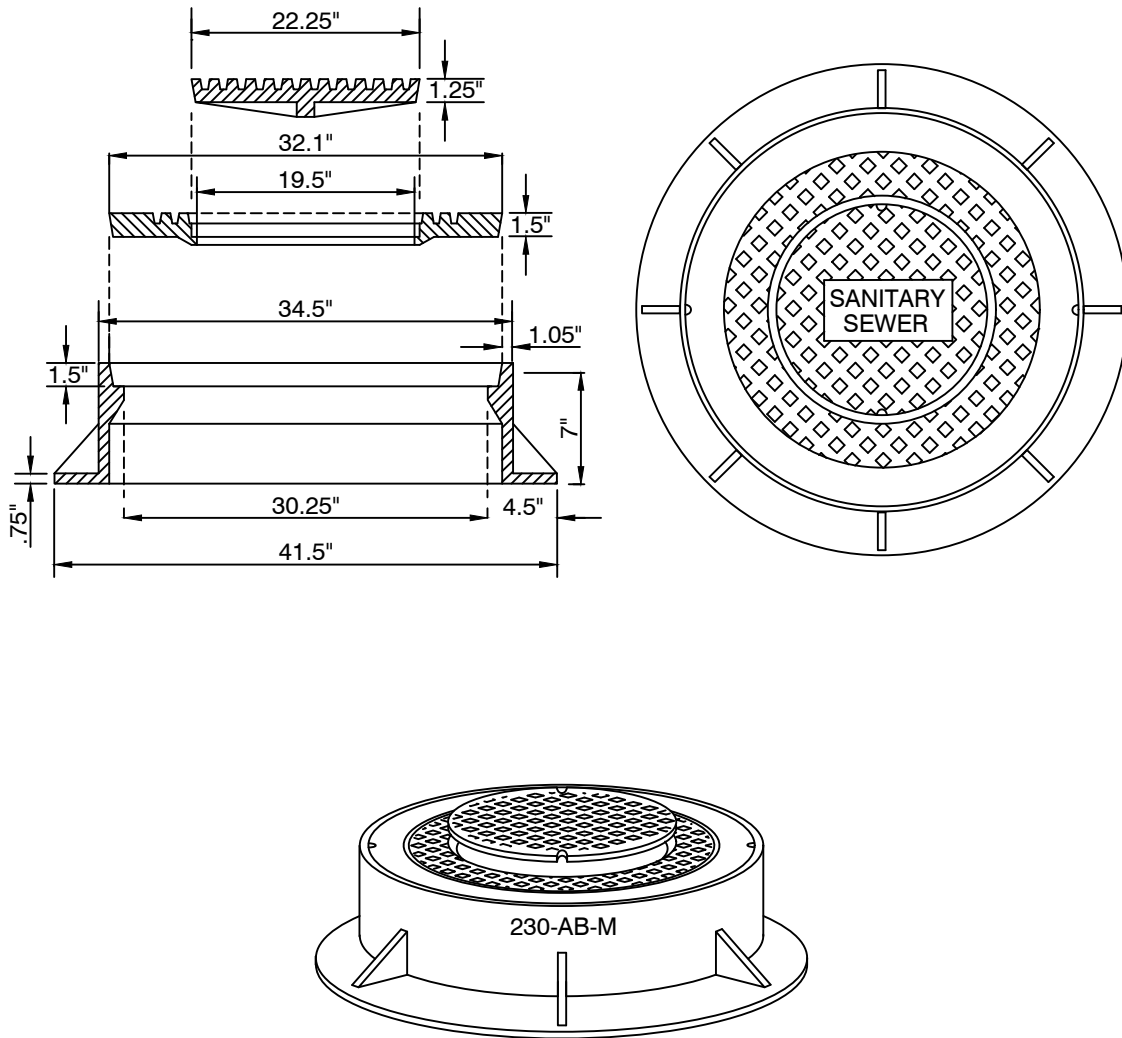

**NOTES:**

1. U.S.F. #230-AB-M MANHOLE RING & DOUBLE COVER, APPROXIMATE TOTAL WEIGHT 605 POUNDS
2. IN CASES WHERE A SHALLOW FRAME IS REQUIRED USF MODEL #655 MAY BE SUBSTITUTED FOR MODEL #230-AB-M

LOXAHATCHEE RIVER DISTRICT

N.T.S.	<b>MANHOLE FRAME AND COVER DETAIL</b>	<b>SD-13</b>
REVISION: APRIL, 2012		

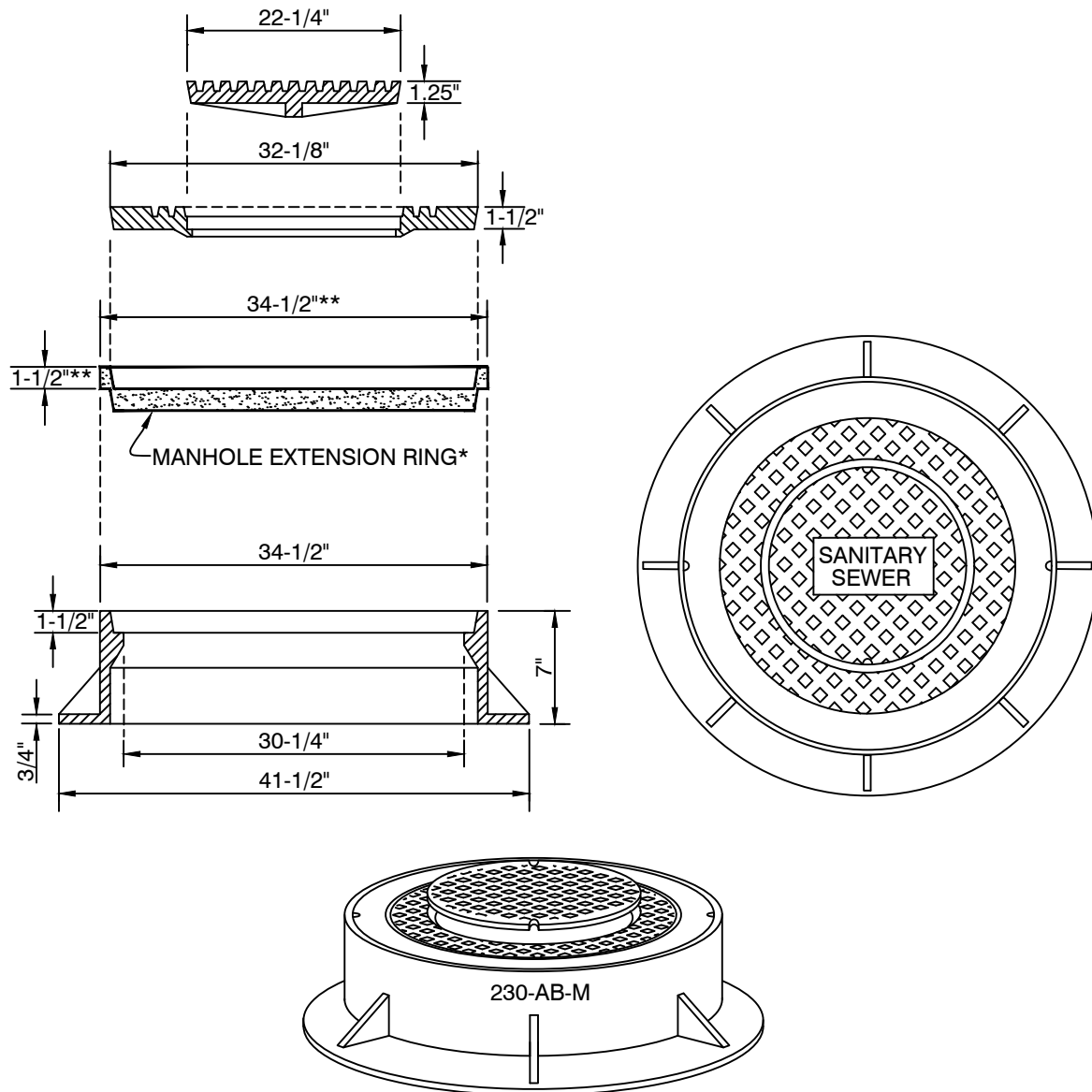

**NOTES:**

1. USE OF THIS DETAIL REQUIRES PRIOR APPROVAL FROM THE DIRECTOR OF ENGINEERING.
2. EXTENSION RINGS SHALL BE POLYPROPYLENE & FIBERGLASS. MANHOLE RINGS AS MANUFACTURED BY: "TURNER COMPANY".
3. ALL SURFACES SHALL BE CLEANED OF ALL DIRT, GREASE, OIL, RUST. METAL SURFACES SHALL BE WIRE BRUSHED.
4. APPLY 3M 4693 ADHESIVE (OR APPROVED EQUAL) TO ALL MATING SURFACES.

LOXAHATCHEE RIVER DISTRICT

N.T.S.	<b>MANHOLE EXTENSION RING DETAIL</b>	<b>SD-14</b>
REVISION: JAN, 2016		

COMPLETELY FILL ANNULUS BETWEEN ADAPTER AND M.H. WALL WITH FIRE CURED CLAY BRICK AND TYPE II PORTLAND CEMENT

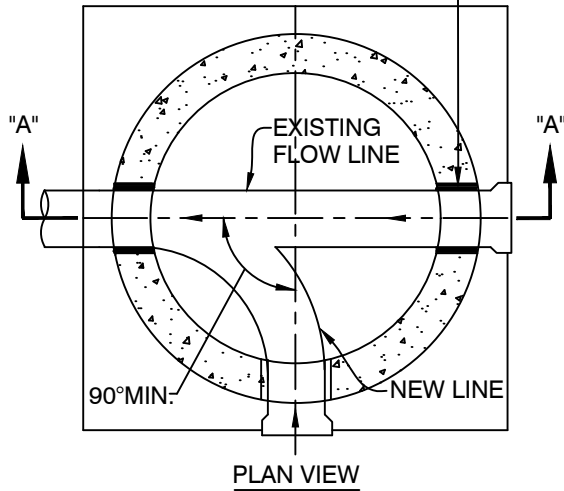

**NOTES:**

1. WHEN THE MAIN LINE IS PVC, A DISTRICT APPROVED HEAVY AGGREGATE COATED PVC M.H. ADAPTER (HARCO OR EQUAL) OR FERNCO M.H. ADAPTER SHALL BE USED. CAST IN PLACE RUBBER BOOTS WITH STAINLESS STEEL HARDWARE (LOCK-JOINT MODEL CP6) MAY BE USED AS AN ALTERNATE.
2. CHANNEL WIDTHS AND INVERT RADII VARY UNIFORMLY FROM END TO END.
3. ALL HOLES FOR PIPES SHALL BE CAST INTO THE MANHOLES. OPENINGS REQUIRED ON ALL EXISTING MANHOLES SHALL BE CORED WITH APPROVED MACHINES.
4. WHEN INVERT DIFFERENTIALS BETWEEN PIPES ENTERING MANHOLES IS 2FT. OR LESS, A "SLIDE" TYPE FLOW CHANNEL SHALL BE CONSTRUCTED TO FORM A SMOOTH FLOW TRANSITION. WHEN TWO (2) OR MORE "SLIDES" HAVE AN INVERT DIFFERENTIAL OF GREATER THAN 0.5FT. AND LESS THAN 2.0FT. THE MANHOLE SHALL BE 5'-0". ALL INSIDE DROP MANHOLE'S SHALL BE 5'-0" I.D. (SEE DETAIL SD-7).
5. A MINIMUM DIFFERENTIAL OF 0.1 FT. SHALL BE PROVIDED BETWEEN THE INLET AND OUTLET PIPE INVERTS

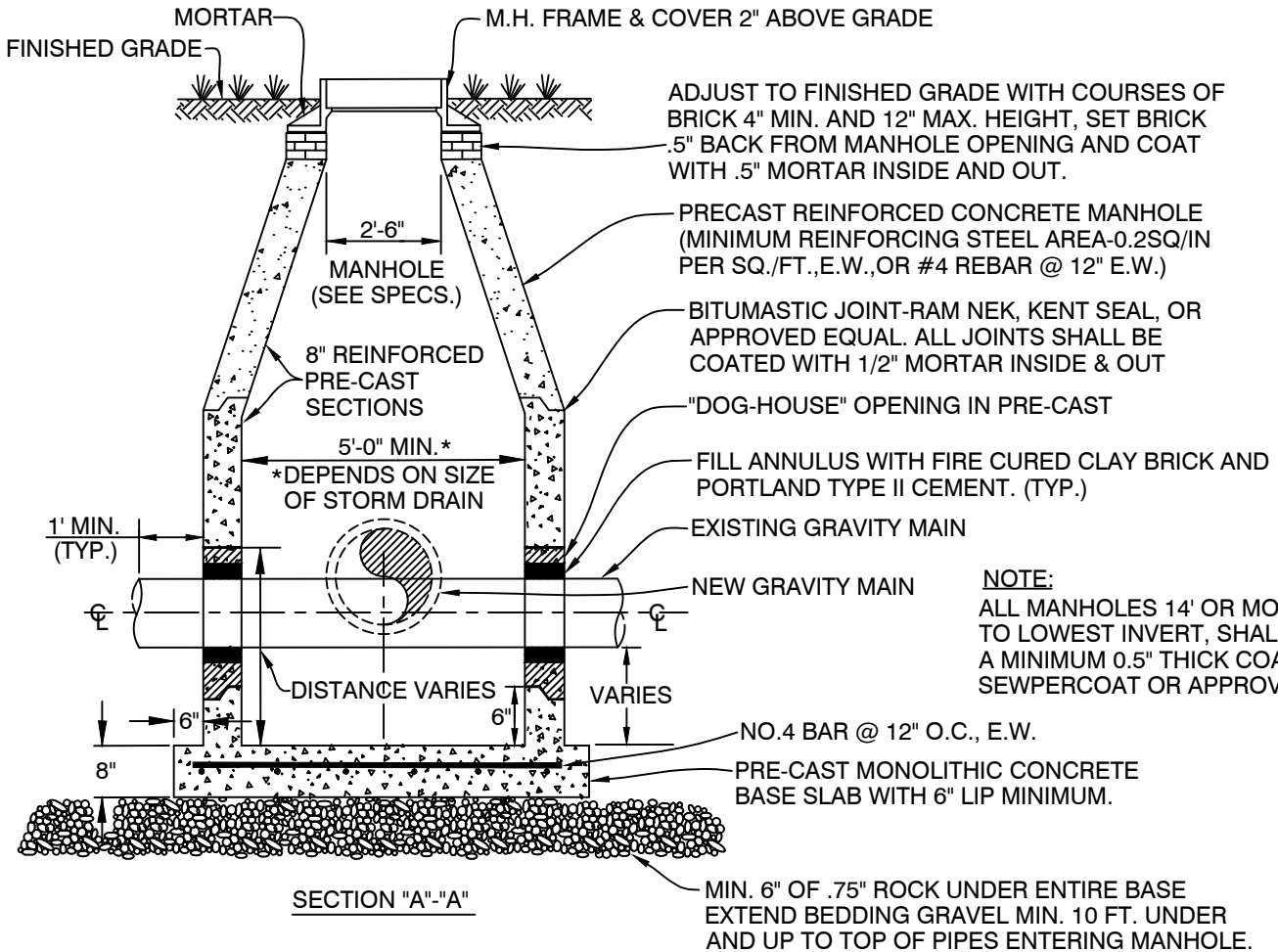

**NOTE:**  
ALL MANHOLES 14' OR MORE FROM RIM TO LOWEST INVERT, SHALL RECEIVE A MINIMUM 0.5" THICK COATING OF SEWPERCOAT OR APPROVED EQUAL.

LOXAHATCHEE RIVER DISTRICT

N.T.S.  
REVISION:  
APRIL, 2012

**DOGHOUSE MANHOLE INSTALLATION INTO AN EXISTING GRAVITY SEWER LINE DETAIL**

**SD-15**

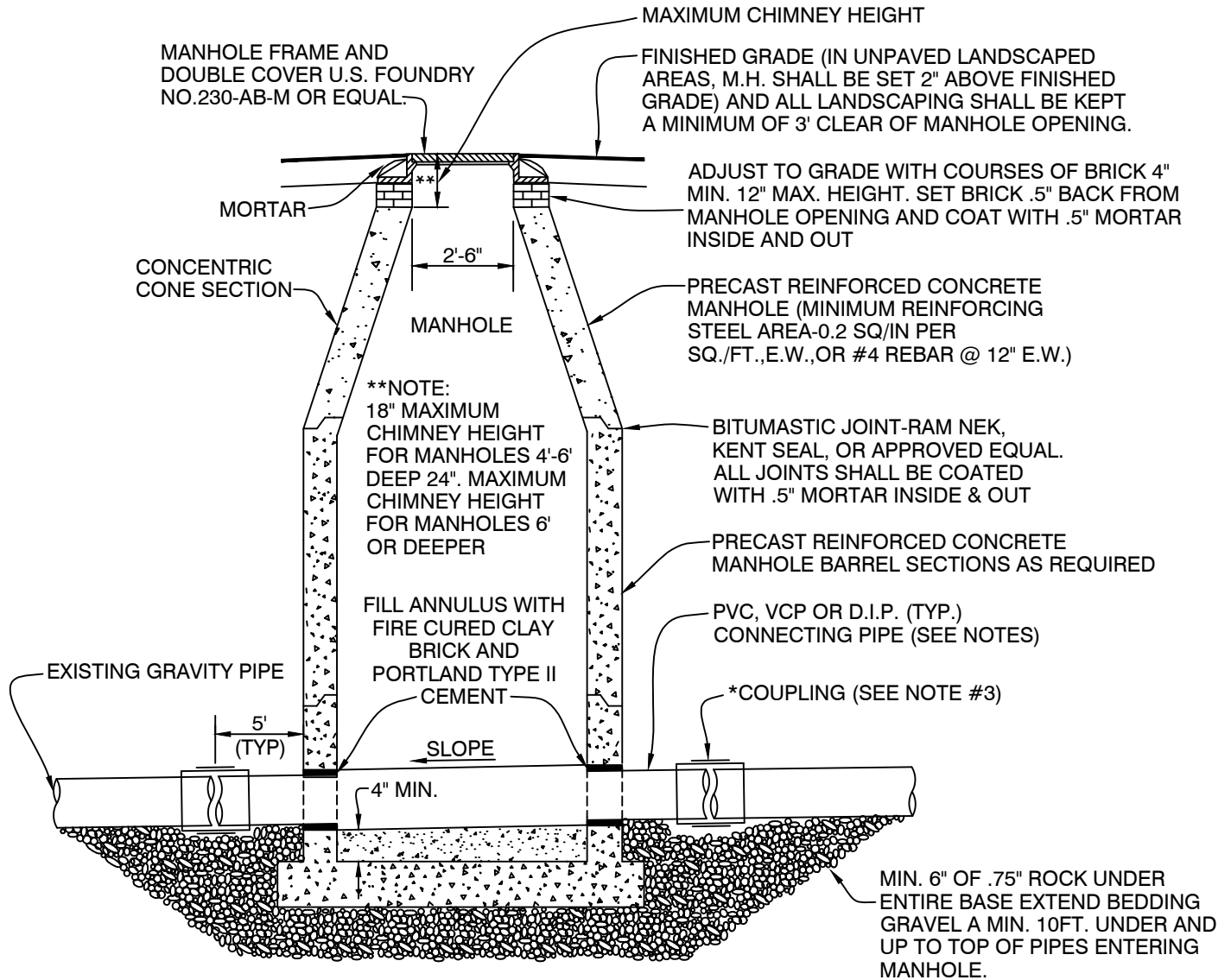

SECTION

**NOTES:**

1. WHEN EXISTING GRAVITY PIPE IS VCP OR SDR-35 PVC, SDR-26 WILL BE USED TO MAKE CONNECTION. WHEN PIPE IS C-900, DIP OR SDR-26, USE SIMILAR PIPE TO RECONNECT.
2. EXISTING SEWAGE FLOWS SHALL BE BY-PASSED BY PUMPING BETWEEN CLOSEST AVAILABLE MANHOLES.
3. \*WHEN EXISTING PIPE IS D.I.P., USE AN APPROVED C-900 COUPLING, WHEN EXISTING PIPE IS V.C.P., USE A FERNCO COUPLING. W/ COPPER WIRE WRAPPED AROUND PIPE AT BOTH ENDS OF FERNCO COUPLING.
4. WHEN THE MAIN LINE IS PVC, A DISTRICT APPROVED HEAVY AGGREGATE COATED PVC M.H. ADAPTER (HARCO OR EQUAL) OR FERNCO M.H. ADAPTER SHALL BE USED.
5. ALL MANHOLES 14' OR MORE FROM RIM TO LOWEST INVERT, SHALL RECEIVE A MINIMUM 0.5" THICK COATING OF SEWPERCOAT OR APPROVED EQUAL.

LOXAHATCHEE RIVER DISTRICT

N.T.S.	<b>SEWER MANHOLE INSTALLATION</b>	
REVISION: APRIL, 2012	<b>INTO AN EXISTING GRAVITY SEWER LINE DETAIL</b>	<b>SD-16</b>

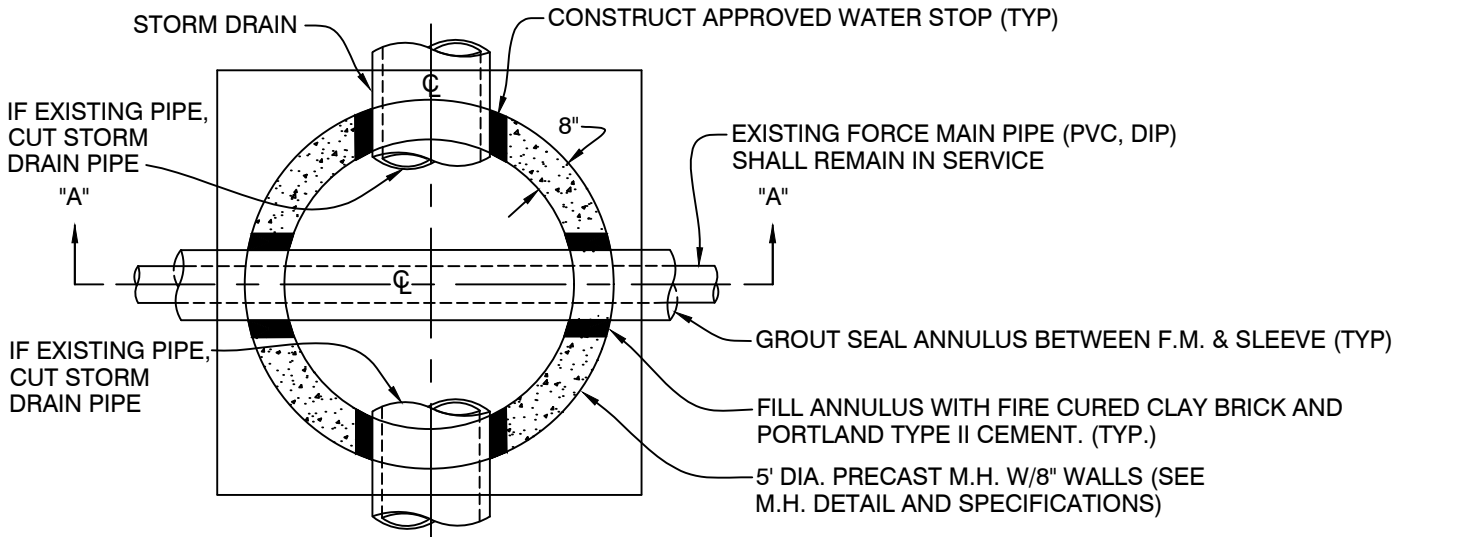

PLAN VIEW

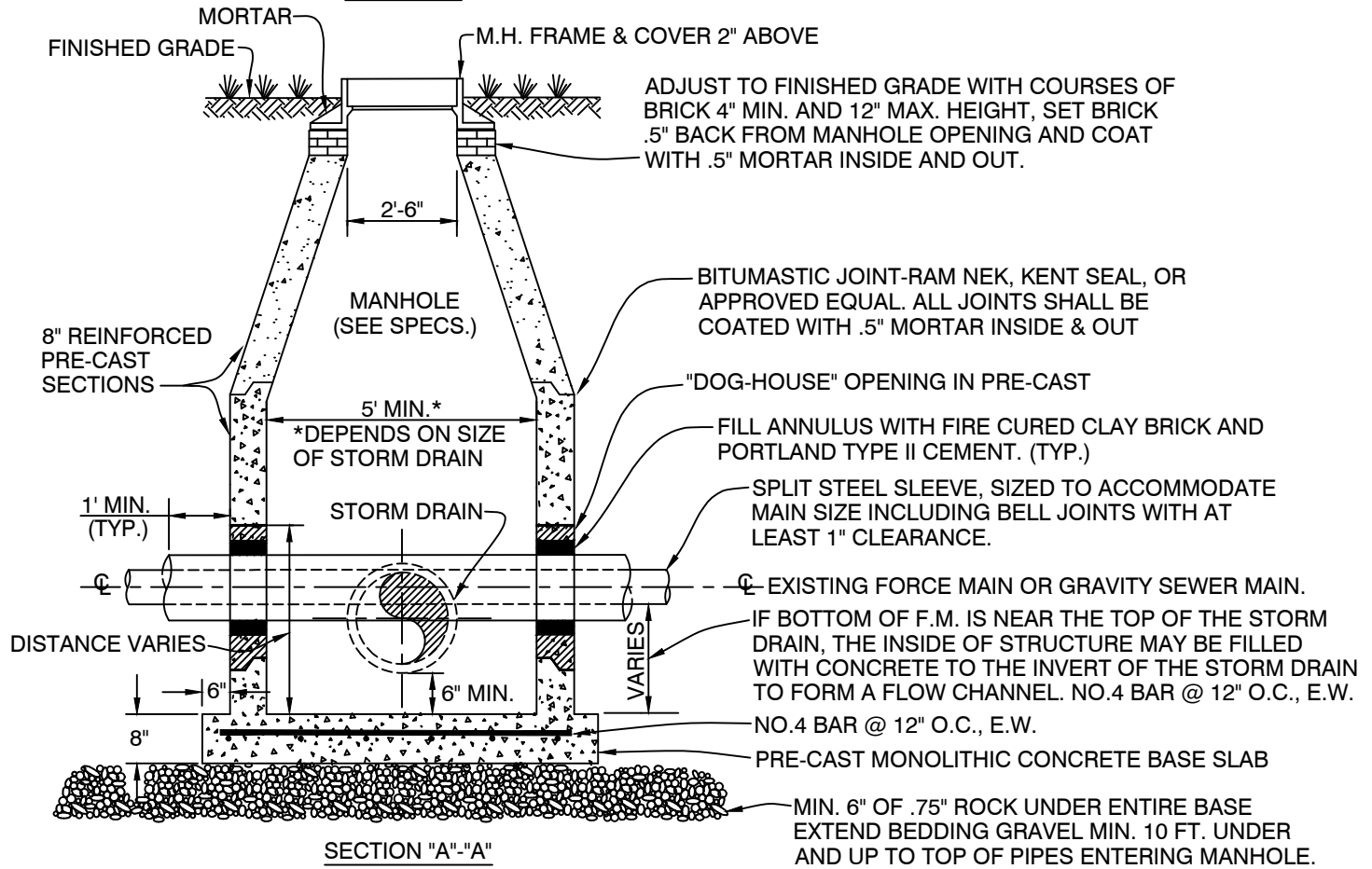

SECTION "A"-"A"

WHERE FORCE MAIN SERVICE CANNOT BE SHUT DOWN

LOXAHATCHEE RIVER DISTRICT

SEWER MAIN / STORM DRAIN  
CONFLICT STRUCTURE DETAIL

SD-17

N.T.S.  
REVISION:  
APRIL, 2012

MINIMUM LENGTH (FT) TO BE RESTRAINED ON EACH SIDE OF FITTING(S)										
TYPE	PIPE SIZE									
	4"	6"	8"	10"	12"	16"	20"	24"	30"	36"
90° BEND	18	24	31	38	43	55	65	75	88	100
45° BEND	8	10	13	15	18	23	26	31	38	43
22-1/2° BEND	4	5	6	8	9	11	13	15	18	20
11-1/4° BEND	2	3	4	5	6	8	9	10	11	13
PLUG OR BRANCH OF TEE	38	50	65	79	90	117	139	163	194	223
VALVE	19	25	32	40	45	59	70	82	98	112
REDUCER	VARIES BY SIZE; TO BE DETERMINED BY THE DESIGN ENGINEER									

**NOTES:**

1. FITTINGS SHALL HAVE RESTRAINED JOINTS UNLESS OTHERWISE INDICATED.
2. INSTALL FULL LENGTH JOINTS WITH TOTAL LENGTH EQUAL TO OR GREATER THAN LENGTH SHOWN IN THE TABLE.
3. WHERE TWO OR MORE FITTINGS ARE IN SERIES, SELECT FITTING RESTRAINT LENGTH THAT YIELDS THE LONGEST RESTRAINT DISTANCE.
4. ALL INLINE VALVES SHALL BE RESTRAINED.
5. WHERE INTERNAL RESTRAINED JOINTS ARE USED, THE ENTIRE BELL SHALL BE PAINTED RED.
6. LENGTHS SHOWN IN THE TABLE WERE CALCULATED IN ACCORDANCE WITH PROCEDURES OUTLINED IN "THRUST RESTRAINT DESIGN FOR DUCTILE IRON PIPE" GUIDELINES PUBLISHED BY DIPRA, USING THE ASSUMPTIONS SHOWN BELOW:

WORKING PRESSURE: 100 PSI  
 SOIL DESIGNATION: SM (SAND SILT)  
 LAYING CONDITIONS: 3  
 DEPTH OF COVER: 3 FT  
 SAFETY FACTOR: 1.5  
 CONVERSION FACTOR FOR PVC PIPE: 1.25

THE DESIGN ENGINEER SHALL INCREASE THE VALUES IN THE TABLE AS WARRANTED BY SITE-SPECIFIC PARAMETERS, SUCH AS SOIL DESIGNATIONS AND LAYING CONDITIONS.

**LOXAHATCHEE RIVER DISTRICT**

N.T.S.	<b>FORCE MAIN THRUST RESTRAINT CHART</b>	<b>SD-18</b>
REVISION: APRIL, 2012		

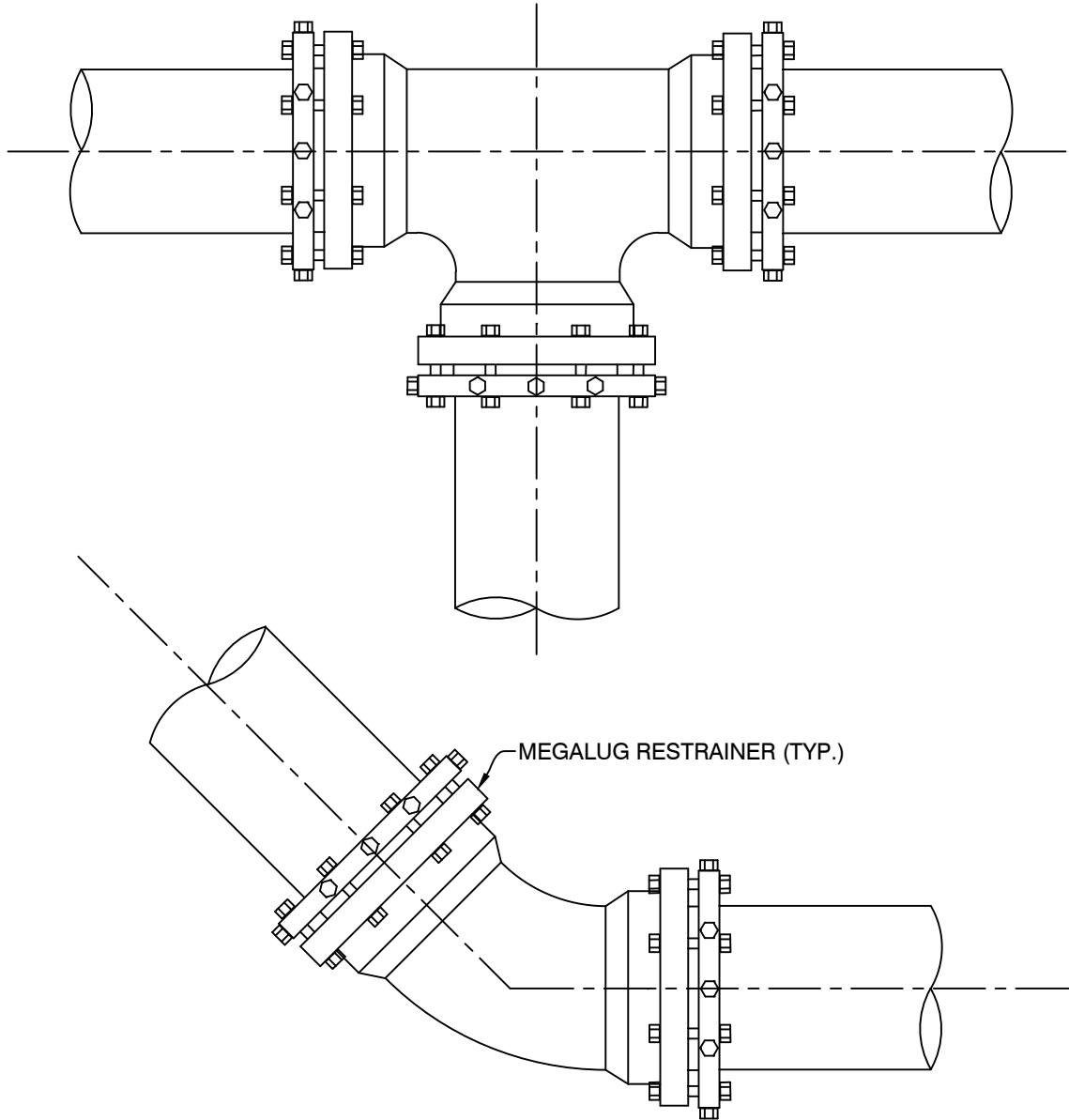

**NOTES:**

1. RETAINER GLANDS FOR PVC PIPE OR DUCTILE IRON PIPE SHALL BE USED AT BEND'S OR TEE'S; RETAINER GLANDS SHALL BE MANUFACTURED BY UNI-FLANGE CORP., OR "MEGALUG" BY EBAA IRON SALES INC., OR DISTRICT APPROVED EQUAL.
2. THE NUMBER OF JOINTS RESTRAINED EACH SIDE OF ANY FITTING OR VALVE SHALL BE IN ACCORDANCE WITH THE MANUFACTURER RECOMMENDATION.
3. ALL BEND'S & TEE'S SHALL HAVE AN EMS INSTALLED.

**LOXAHATCHEE RIVER DISTRICT**

N.T.S.

REVISION:  
APRIL, 2012

**FORCE MAIN THRUST RESTRAINT DETAIL**

**SD-19**

MEGALUG RESTRAINT BY EBAA IRON  
IN ACCORDANCE WITH  
MANUFACTURER'S SPECIFICATIONS.

\*IF TEST BLOWOFF USED IT WILL BE REMOVED PRIOR  
TO FINAL, M.J. PLUG INSTALLED OR 2" BRASS PLUG  
INSTALLED AND LEFT IN CLOSED POSITION.

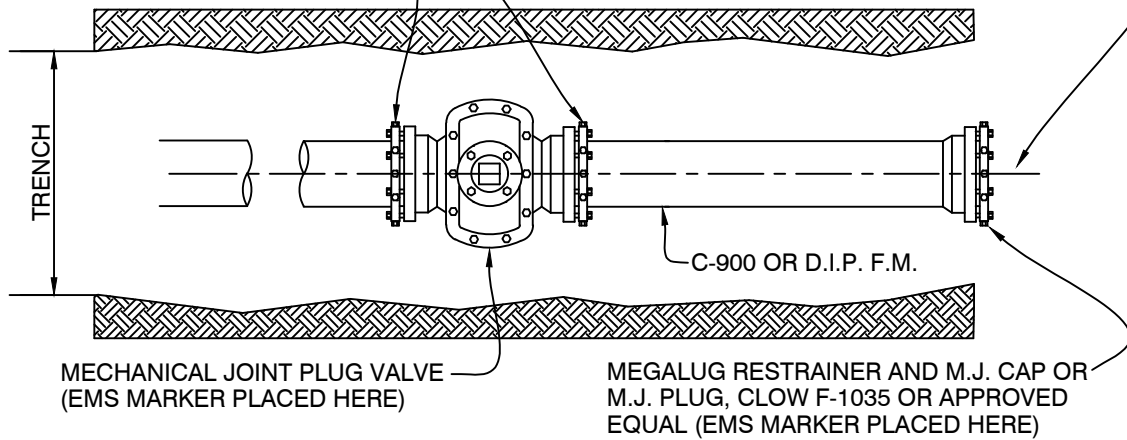

PLAN

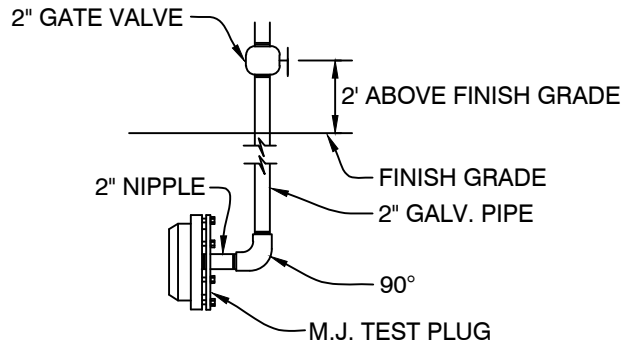

TEST BLOWOFF

NOTE:  
ALL JOINTS WILL BE RESTRAINED BY "MEG-A-LUG" RESTRAINERS  
AS MANUFACTURED BY EBAA IRON. THE NUMBER OF JOINTS TO BE  
RESTRAINED SHALL BE BASED ON MANUFACTURER'S  
RECOMMENDATIONS FOR APPLICABLE TEST PRESSURE RATINGS.

LOXAHATCHEE RIVER DISTRICT

N.T.S.  
REVISION:  
APRIL, 2012

FORCE MAIN TERMINAL END DETAIL

SD-20



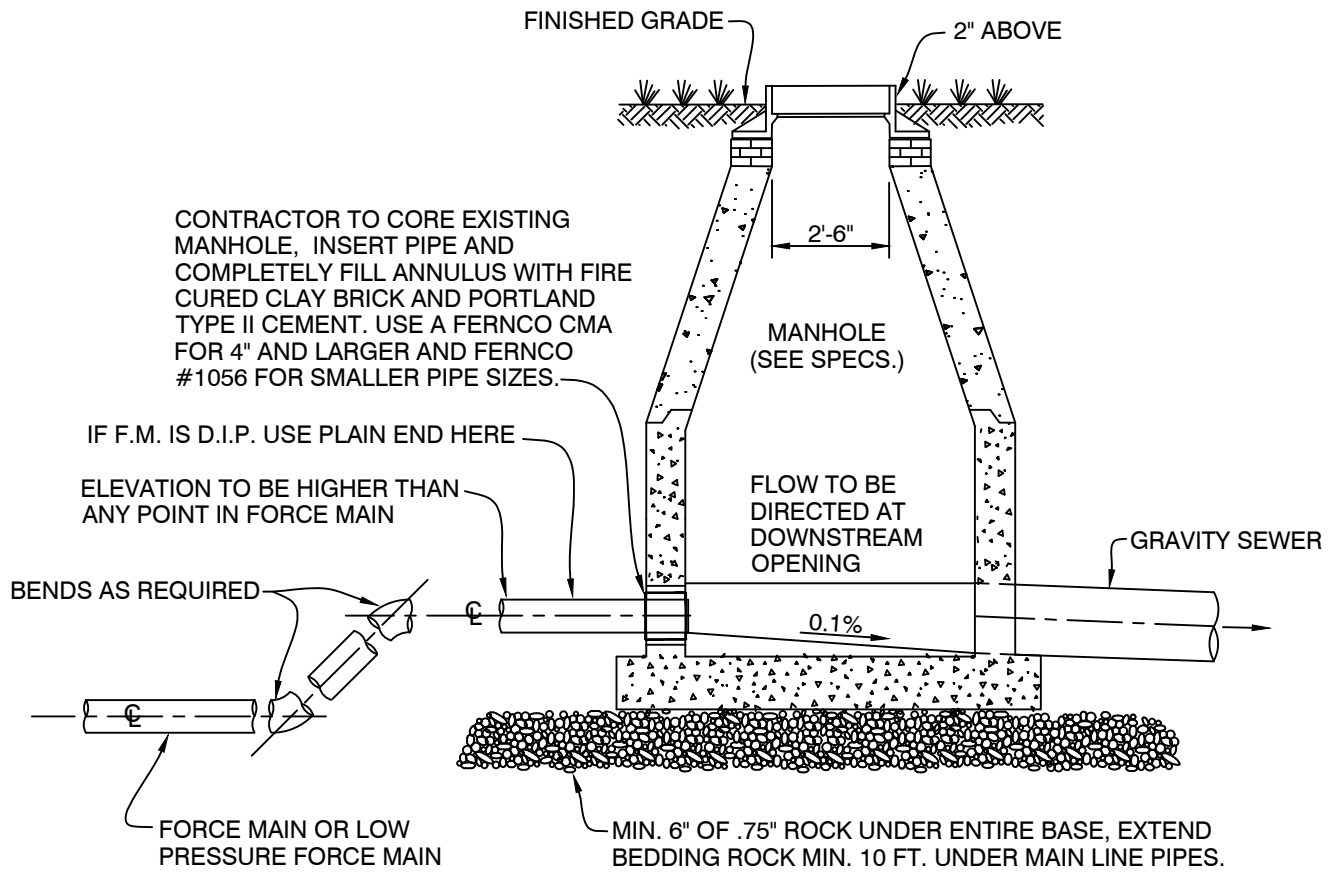

**NOTES:**

1. WHEN ELEVATION OF FORCE MAIN AT MANHOLE IS HIGHEST POINT OF FORCE MAIN, BENDS CAN BE ELIMINATED.

LOXAHATCHEE RIVER DISTRICT

N.T.S.

REVISION:  
APRIL, 2012

**FORCE MAIN INTO SHALLOW MANHOLE DETAIL**

**SD-21**

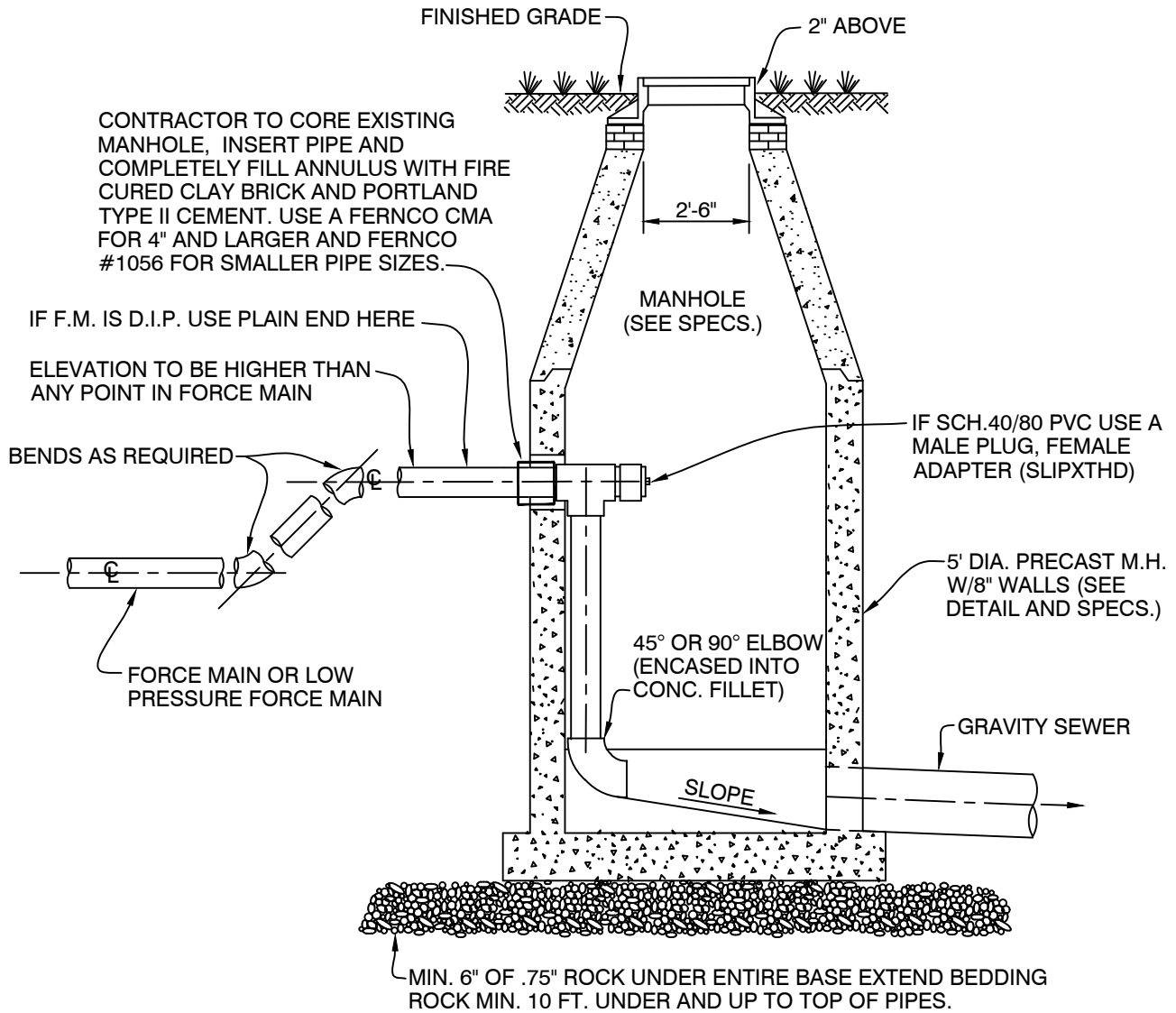

**NOTES:**

1. ALL DROP PIPING INCLUDING TEE SHALL BE D.I.P., PVC (C-900), OR SCH 40/80 PVC.
2. MANHOLE SHALL RECEIVE A MINIMUM 0.5" THICK COATING OF SEWPERCOAT OR APPROVED EQUAL.

**LOXAHATCHEE RIVER DISTRICT**

N.T.S.  
 REVISION:  
 APRIL, 2012

**FORCE MAIN INTO DEEP MANHOLE DETAIL**

**SD-22**

M.H. COVER TO BE PLACED 2" ABOVE  
FINISHED GRADE IN LANDSCAPED AREAS

FRAME AND DOUBLE COVER U.S.  
FOUNDRY #230-AB-M OR EQUAL

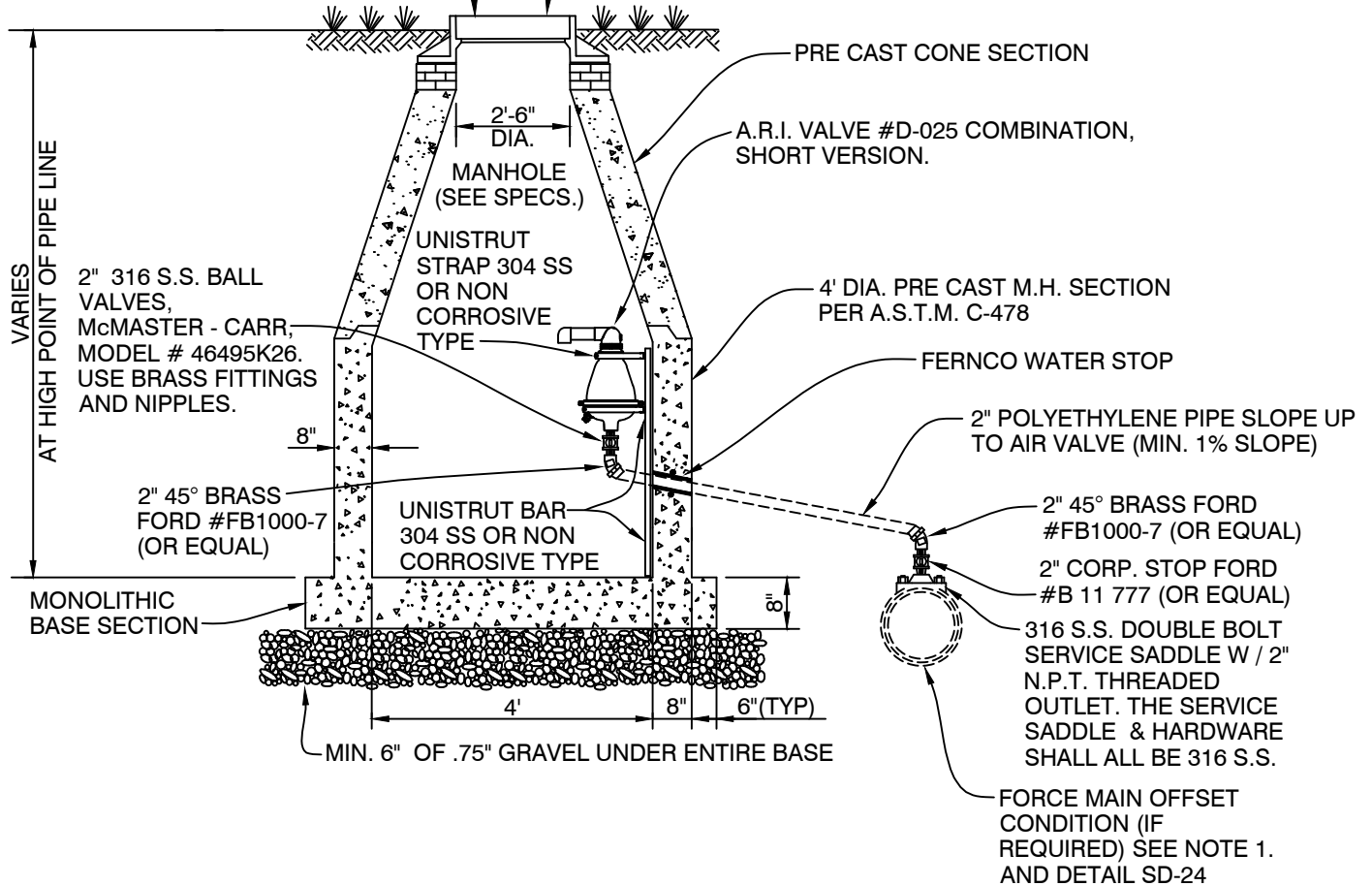

**NOTES:**

1. FOR OFFSET CONDITION, AIR VALVE IN MANHOLE STRUCTURE SHALL BE ADEQUATELY SUPPORTED ON S.S. UNISTRUT BAR ANCHORED TO THE CONCRETE WALLS OF MANHOLE AND/OR ANCHORED TO THE CONCRETE ON MANHOLE FLOOR.
2. UNISTRUT BARS SHALL BE 304 S.S. OR NON CORROSIVE TYPE, STRAPS ANCHORING A.R.V. TO UNISTRUT TO BE OF SAME TYPE MATERIAL.

**LOXAHATCHEE RIVER DISTRICT**

**AUTOMATIC AIR RELEASE VALVE  
OFFSET FORCE MAIN CONDITION DETAIL**

**SD-23**

N.T.S.

REVISION:  
APRIL, 2012

M.H. COVER TO BE PLACED 2" ABOVE FINISHED GRADE IN LANDSCAPED AREAS

FRAME AND DOUBLE COVER U.S. FOUNDRY #230-AB-M OR EQUAL

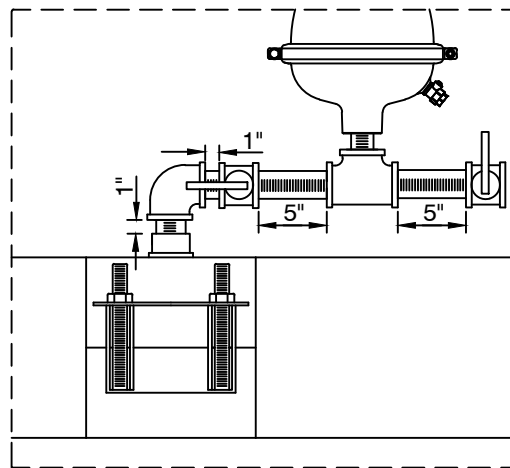
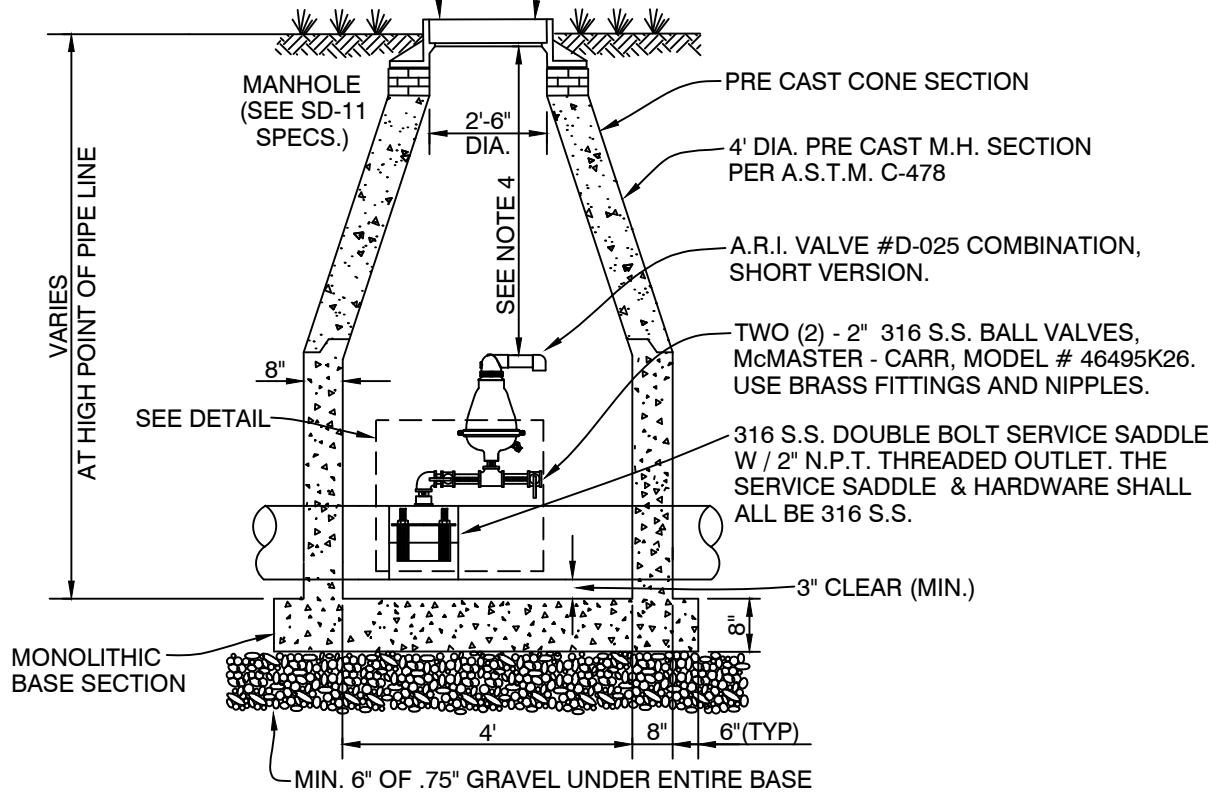

DETAIL

**NOTES:**

1. IF OFFSET CONDITION IS UTILIZED, AIR VALVE IN MANHOLE STRUCTURE SHALL BE ADEQUATELY SUPPORTED ON A 4" THICK CONCRETE PAD ON M.H. FLOOR.
2. CENTER ARV UNDER MH OPENING.
3. IN SITUATIONS WHERE A FORCE MAIN CROSSES A CANAL OR IS ATTACHED TO A BRIDGE, WHERE A STRUCTURE IS NOT NECESSARY, AN A.R.V TYPE A.R.I. MODEL #D-025 SHALL BE USED.
4. TOP OF AIR RELEASE VALVES SHALL BE NO LESS THAN 12" FROM INSIDE MANHOLE RIM ELEVATION AND NO GREATER THAN 24".

**LOXAHATCHEE RIVER DISTRICT**

N.T.S.  
 REVISION:  
 APRIL, 2012

**AUTOMATIC AIR RELEASE VALVE DETAIL**

**SD-24**

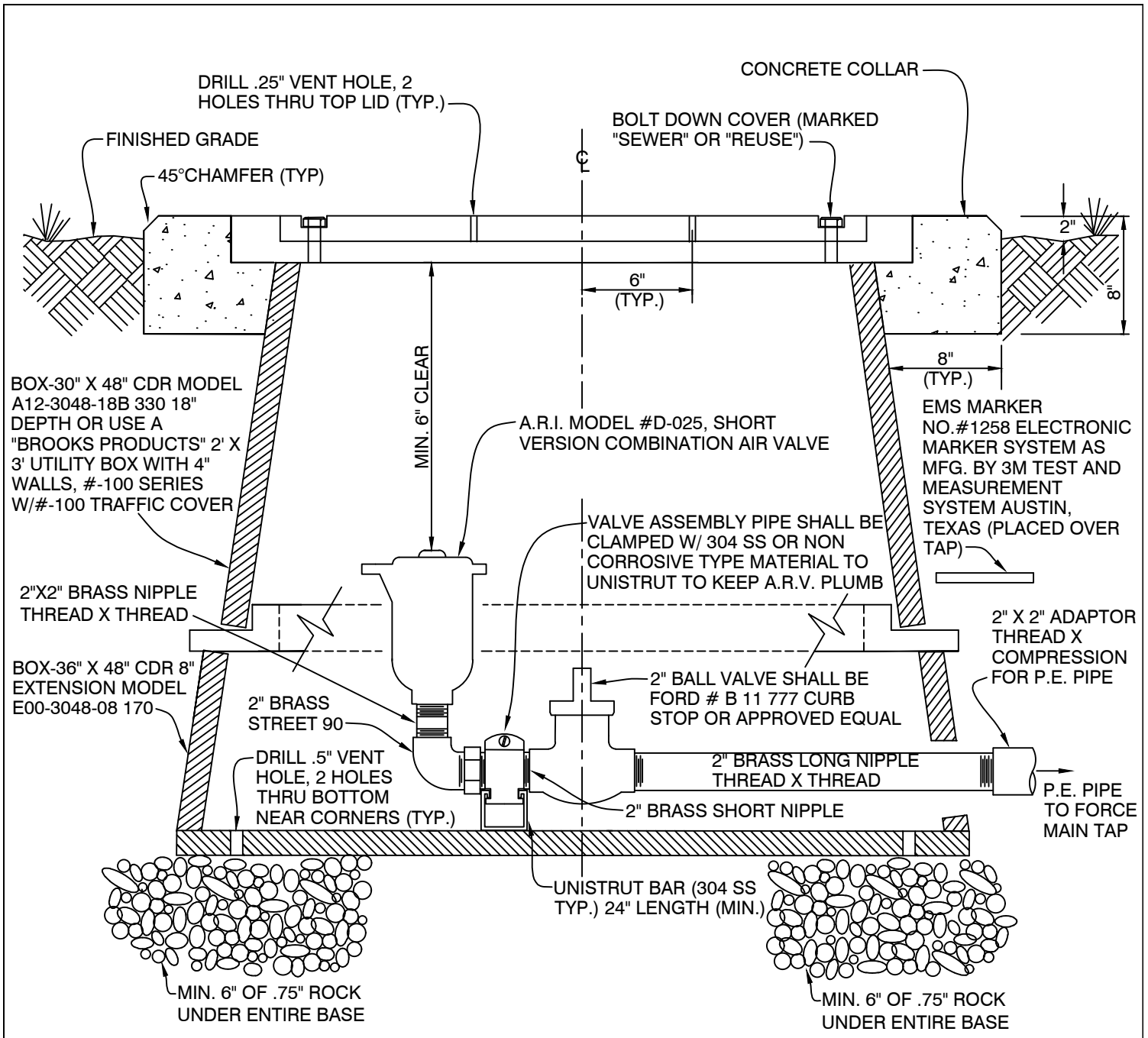

**NOTES:**

1. THIS DETAIL TO BE USED ONLY WITH DISTRICTS' PRIOR APPROVAL.
2. FORCE MAIN TAP SHALL BE DONE WITH 2" DOUBLE STRAP SERVICE SADDLE. BODY, STRAP & HARDWARE SHALL BE 316 S.S. THE ISOLATION VALVE AT THE TAP SHALL BE A 2" FORD CORP STOP # B 11 777.

**LOXAHATCHEE RIVER DISTRICT**

N.T.S.	<b>TYPICAL FORCE MAIN AIR RELEASE VALVE DETAIL ALTERNATE OFFSET CONFIGURATION</b>	<b>SD-25</b>
REVISION: APRIL, 2012		

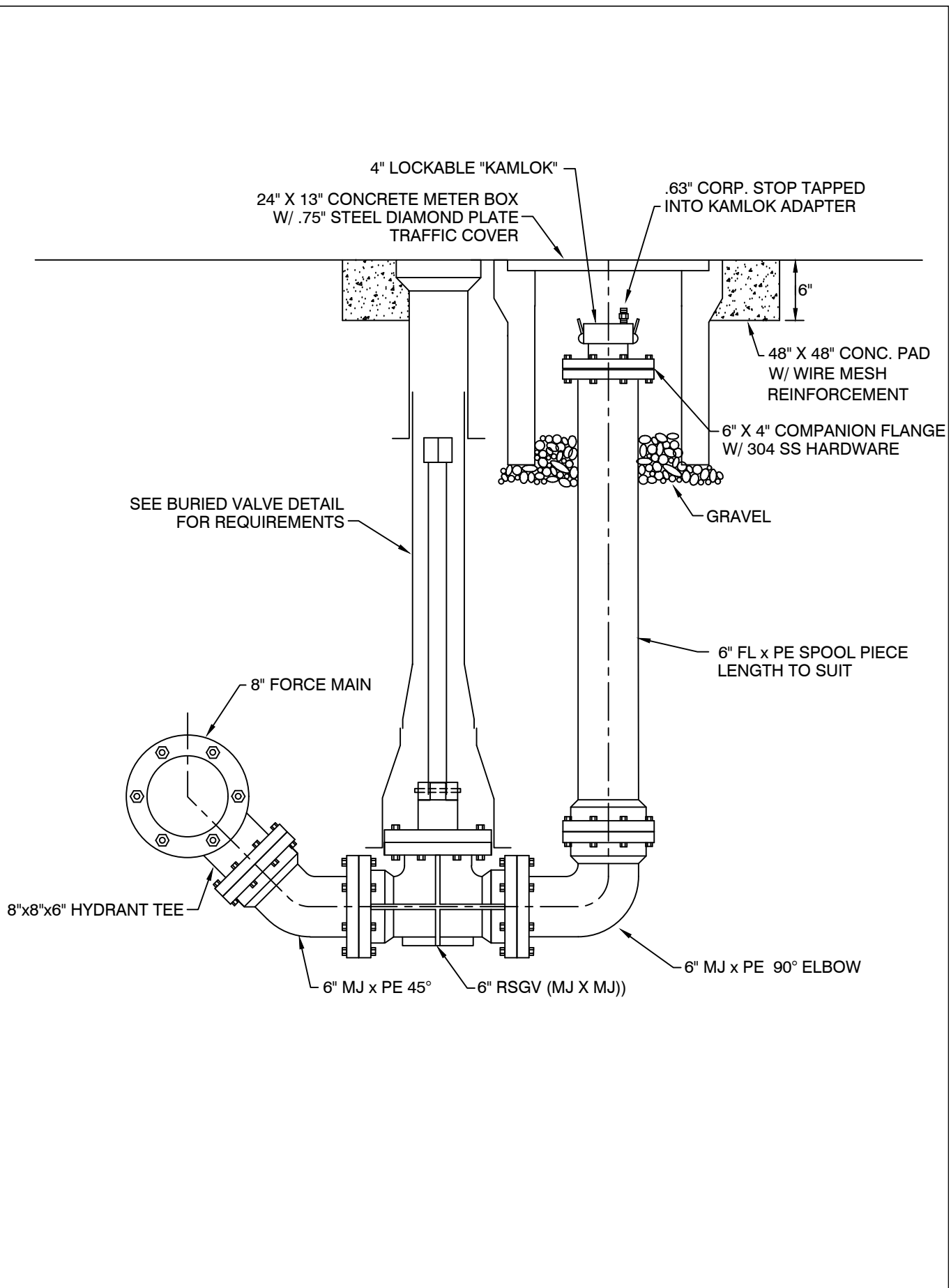

LOXAHATCHEE RIVER DISTRICT

N.T.S.  
REVISION:  
JUNE, 2014

FORCE MAIN DRAIN DETAIL

SD-26

METAL VALVE COVER MARKED "REUSE WATER" COLORED PURPLE FOR REUSE

METAL VALVE COVER MARKED "SEWER" FOR FORCE MAIN

45° CHAMFER (TYP)

POUR CONCRETE COLLAR (18"X18"X8") W/WIRE MESH REINFORCEMENT

FINISHED GRADE

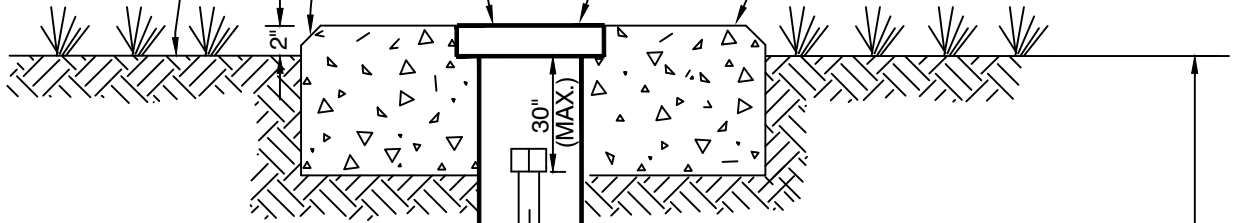

VALVE STEM EXTENSION\*

EMS MARKER NO.#1258 ELECTRONIC MARKER SYSTEM AS MFG. BY 3M TEST AND MEASUREMENT SYSTEM AUSTIN, TEXAS

VALVE BOX, THREE PIECE C.I. TYLER SERIES 6860 W/#6 BASE OR EQUAL

\*WHEN VALVE OPERATING NUT IS DEEPER THAN 30" FROM FINISHED GRADE, AN APPROVED EXTENSION STEM, PINNED TO THE VALVE OPERATING NUT, SHALL BE USED.

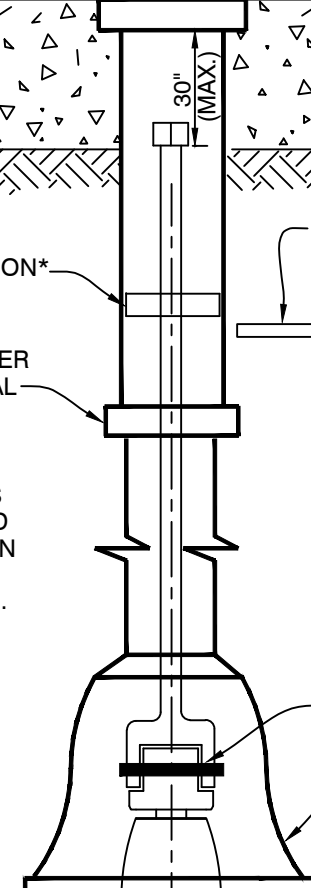

.75" x 3" 302 S.S. ROLL PIN THRU 2" SQUARE OPERATING NUT

BASE TO BE PLACED ON COMPACTED BACKFILL

VALVE (SEE SPECIFICATIONS)

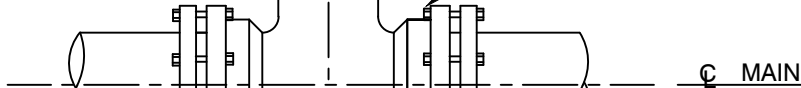

CL MAIN

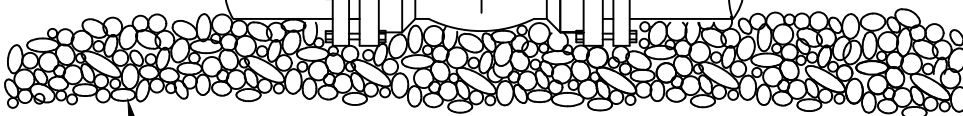

PLACE MIN. 6" #57 ROCK BEDDING FOR PIPE/VALVE SUPPORT

(SEE PLANS)

### FORCE MAIN OR REUSE WATER SYSTEM

LOXAHATCHEE RIVER DISTRICT

N.T.S.

REVISION:  
APRIL, 2012

## BURIED VALVE DETAIL

SD-27

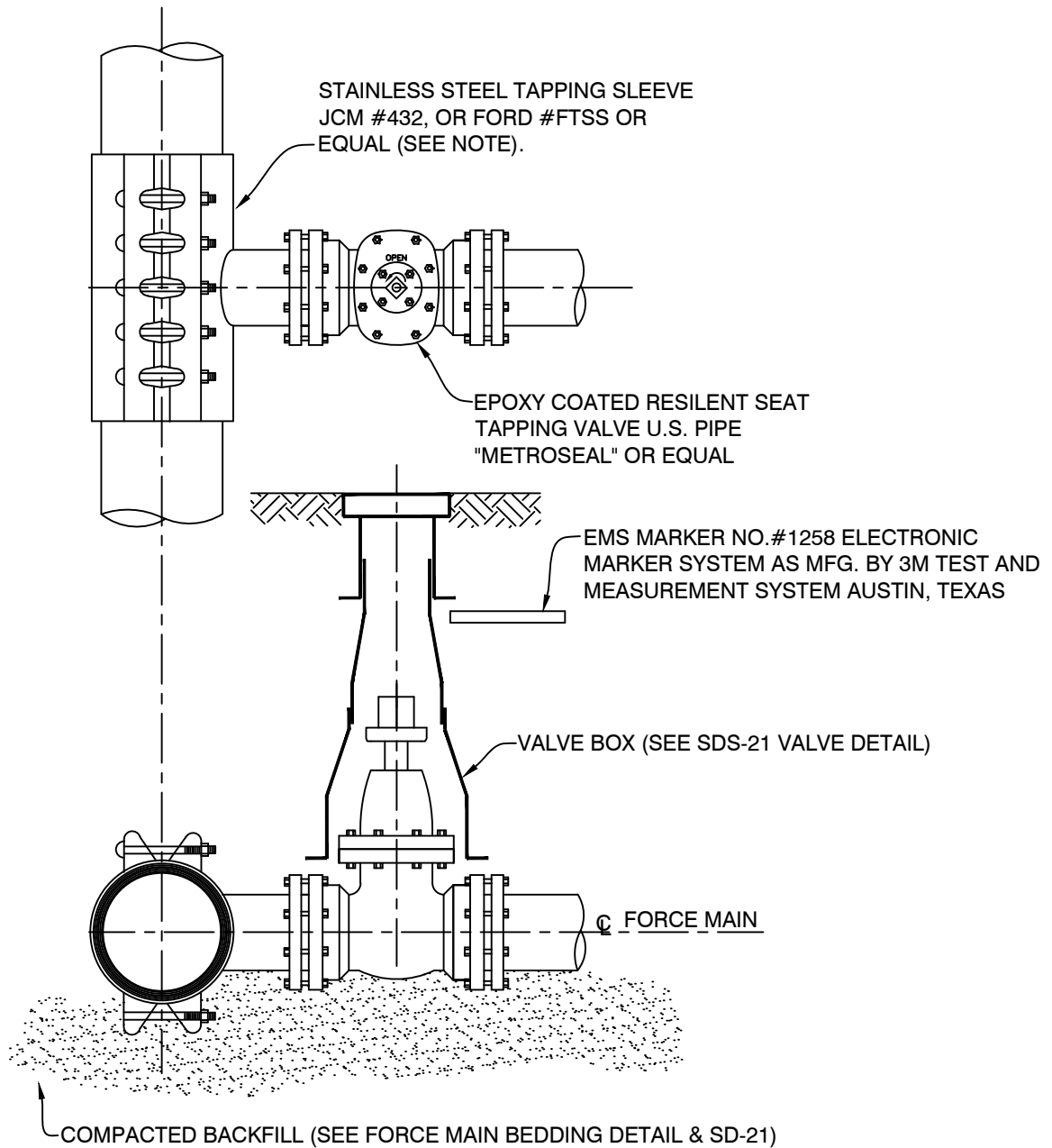

NOTE:  
ALL SLEEVES SHALL BE PRESSURE TESTED.

LOXAHATCHEE RIVER DISTRICT

N.T.S.  
REVISION:  
APRIL, 2012

TAPPING FORCE MAIN DETAIL

SD-28



THE FOLLOWING SHALL BE USED AS A GUIDE FOR SUBMITTAL OF RECORD DRAWINGS TO THE LOXAHATCHEE RIVER DISTRICT

1. TWO (2) SETS OF PRINTS SHALL BE SUBMITTED TO THE DISTRICT FOR REVIEW 48 HOURS PRIOR TO REQUESTING INSPECTIONS SUCH AS, FINAL INSPECTION, PRESSURE TESTS, SANITARY SEWER LAMPING OR ANY OTHER ELEMENT OF THE SYSTEM WHICH IS DETERMINED BY THE DISTRICT TO REQUIRE CLARIFICATION.
2. THE DRAWINGS WILL BE REVIEWED BY THE DISTRICT FOR DEFICIENCIES. DEFICIENCIES WILL BE INDICATED ON ONE (1) SET OF PRINTS WHICH WILL BE RETURNED TO THE E.O.R. OR CONTRACTOR FOR NECESSARY CORRECTIVE ACTION.
3. UPON CORRECTION, TWO (2) SETS OF PRINTS (SIGNED/SEALED BY A FLORIDA LICENSED SURVEYOR) SHALL BE SUBMITTED.
4. NO DISCLAIMERS ON DRAWINGS WILL BE ACCEPTED.
5. UPON FINAL SUBMITTAL OF RECORD DRAWINGS, AN AUTOCAD VER. 2009 OR LATER AND ADOBE .PDF (24"X36") ELECTRONIC DATA FILE SHALL BE FURNISHED ON A CD-R DISK TO THE DISTRICT. ONLY ONE CAD FILE WITH ALL SHEETS OF RECORD DRAWINGS ALLOWED.
6. ALL SEWER ITEMS SHALL BE CATEGORIZED AND ASSIGNED TO THE DRAWING LAYERS SUCH AS: AB-MANHOLES, AB-FORCEMAIN, AB-VALVE, AB-GRAVITY MAIN, ETC.
7. REDRAW ALL SEWER LINES AND INFRASTRUCTURE ON RECORD DRAWINGS AS CONSTRUCTED HORIZONTALLY & VERTICALLY. USING ORIGINAL DESIGN LINEWORK & ONLY UPDATING THE CORRESPONDING TEXT CALLOUTS WILL NOT BE ACCEPTED AS RECORD DRAWINGS.

REQUIRED INFORMATION ON RECORD DRAWINGS

GENERAL

1. DRAWINGS ON 24" X 36" BOND PAPER THAT WILL REPRODUCE LEGIBLY.
2. LABEL DRAWINGS "RECORD DRAWINGS" WITH DATE. COMPLETE TITLE BLOCK WITH CURRENT FILE NAME.
3. DRAWINGS SHALL BE SIGNED / SEALED BY A FORIDA LICENSED PROFESSIONAL LAND SURVEYOR.
4. CORRECT STREET/ROAD NAMES AND LOT AND BLOCK NUMBERS.
5. SHOW AS-BUILT CONSTRUCTED SEWER FACILITIES HEAVIED UP, BOLD OR BOXED OUT TO STAND OUT FROM REST OF EACH DRAWING.
6. ALL ITEMS LISTED BELOW MUST BE CORRECTLY GEOREFERENCED WITH NORTHINGS/EASTINGS CLEARLY SHOW. THE AS BUILTS SHALL BE GEOREFERENCED TO THE STATE PLANE COORDINATES IN NAD 83, FLORIDA EAST ZONE, WHILE THE VERTICAL DATUM SHALL BE NGVD 29.

GRAVITY SEWER

1. AS-BUILT DISTANCE OF GRAVITY MAIN FROM CENTER LINE OF ROAD OR EASEMENT RIGHT- OF-WAY LINE, BUILDINGS, OR AS DETERMINED BY THE LOXAHATCHEE RIVER DISTRICT. EXTENSIONS OF AN IMAGINARY LINE WILL NOT BE ACCEPTABLE AS REFERENCED POINTS.
2. TYPE OF MATERIALS INSTALLED - MAINS AND SERVICES.
3. SHOW EACH SEWER SERVICE LATERAL INCLUDING THE CONNECTION TO THE MAIN AND PROVIDE THE NORTHING & EASTING POINTS FOR EACH CLEANOUT & INDICATE CLEANOUT DIAMETER.
4. AS-BUILT LOCATIONS OF MANHOLES WITH A NORTHING & EASTING PROVIDED.
5. AS-BUILT ELEVATIONS, RIM ELEVATION, EACH INVERT AND PIPE SLOPE.
6. UPDATE LIFT STATION DETAILS/ELEVATIONS INCLUDING START UP DATA.
7. LIFT STATION AND UTILITY EASEMENTS, INCLUDING LOCATION OF F.P.&L. SERVICE TO CONTROL PANEL.

PRESSURE PIPE

1. AS-BUILT DISTANCE OF MAINS AT 100' INTERVALS FROM CENTER LINE OF ROAD, EASEMENT, RIGHT-OF-WAY LINE, BUILDINGS, SEWER MAINS OR AS DETERMINED BY THE LOXAHATCHEE RIVER DISTRICT. EXTENSIONS OF AN IMAGINARY LINE WILL NOT BE ACCEPTABLE AS REFERENCED POINTS.
2. SHOW ELEVATIONS, NORTHING/EASTING OF EACH VALVE, FITTING, AIR RELEASE VALVE, SERVICE LINE, TAP, ETC., AND RADIAL DIMENSIONS (TIES) FROM A NEARBY PERMANENT OBJECT WHERE POSSIBLE. (SEE NOTE NO. 6 IN GENERAL).
3. TYPE OF MATERIALS INSTALLED - PIPE AND APPURTENANCES. INDICATE ALL LOCATIONS OF CHANGE OF MATERIAL INCLUDING JOINT TYPE (M.J., SLIP, RESTRAINED).
4. VALVE TYPE (BUTTERFLY, GATE, PLUG) INCLUDING THE NORTHING & EASTING POINT.
5. AS-BUILT LENGTH OF ALL JACK AND BORE CASINGS INDICATING DISTANCE FROM CENTER LINE OF PAVING TO EACH END OF CASING. THE AS-BUILT INVERT ELEVATION OF EACH END OF CASING, (INCLUDING NORTHING/EASTING) AND AS-BUILT DISTANCE FROM EACH END OF CASING TO LIMITS OF MECHANICAL JOINT PIPE IS ALSO REQUIRED.
6. AS-BUILT ELEVATIONS AT 100' INTERVALS AS WELL AS ANY MAJOR CHANGES IN DIRECTION AND/OR ELEVATION. ELEVATIONS SHOWN AT THESE INTERVALS AND CHANGES MUST SHOW TOP OF PIPE ELEVATION, NORTHING/EASTING AND FINISHED GRADE ELEVATION AT THAT LOCATION. SHOW LOCATION OF EMS MARKERS.
7. UTILITY EASEMENTS SHALL BE CORRECTLY SHOWN AND DIMENSIONED WITH REFERENCED SEWER FACILITY.

**LOXAHATCHEE RIVER DISTRICT**

N.T.S.	<b>RECORD DRAWING SUBMITTAL GUIDE</b>	<b>SD-29</b>
REVISION: APRIL, 2012		

# SEPARATION REQUIREMENTS

62-555.314 F.A.C. AUGUST 28, 2003

1. HORIZONTAL SEPARATION BETWEEN UNDERGROUND WATER MAINS AND SANITARY OR STORM SEWERS, WASTEWATER OR STORMWATER FORCE MAINS, RECLAIMED WATER PIPELINES, AND ON-SITE SEWAGE TREATMENT AND DISPOSAL SYSTEMS.
  - A. NEW OR RELOCATED UNDERGROUND WATER MAINS SHALL BE LAID TO PROVIDE A HORIZONTAL DISTANCE OF AT LEAST THREE FEET BETWEEN THE OUTSIDE OF THE WATER MAIN AND THE OUTSIDE OF ANY EXISTING OR PROPOSED STORM SEWER, STORMWATER FORCE MAIN, OR PIPELINE CONVEYING RECLAIMED WATER REGULATED UNDER PART III OF CHAPTER 62-610, F.A.C.
  - B. NEW OR RELOCATED, UNDERGROUND WATER MAINS SHALL BE LAID TO PROVIDE A HORIZONTAL DISTANCE OF AT LEAST THREE FEET, AND PREFERABLY TEN FEET, BETWEEN THE OUTSIDE OF THE WATER MAIN AND THE OUTSIDE OF ANY EXISTING OR PROPOSED VACUUM-TYPE SANITARY SEWER.
  - C. NEW OR RELOCATED, UNDERGROUND WATER MAINS SHALL BE LAID TO PROVIDE A HORIZONTAL DISTANCE OF AT LEAST SIX FEET, AND PREFERABLY TEN FEET, BETWEEN THE OUTSIDE OF THE WATER MAIN AND THE OUTSIDE OF ANY EXISTING OR PROPOSED GRAVITY- OR PRESSURE-TYPE SANITARY SEWER, WASTEWATER FORCE MAIN, OR PIPELINE CONVEYING RECLAIMED WATER NOT REGULATED UNDER PART III OF CHAPTER 62-610, F.A.C. THE MINIMUM HORIZONTAL SEPARATION DISTANCE BETWEEN WATER MAINS AND GRAVITY-TYPE SANITARY SEWERS SHALL BE REDUCED TO THREE FEET WHERE THE BOTTOM OF THE WATER MAIN IS LAID AT LEAST SIX INCHES ABOVE THE TOP OF THE SEWER.
2. VERTICAL SEPARATION BETWEEN UNDERGROUND WATER MAINS AND SANITARY OR STORM SEWERS, WASTEWATER OR STORMWATER FORCE MAINS, AND RECLAIMED WATER PIPELINES.
  - A. NEW OR RELOCATED, UNDERGROUND WATER MAINS CROSSING ANY EXISTING OR PROPOSED GRAVITY- OR VACUUM-TYPE SANITARY SEWER OR STORM SEWER SHALL BE LAID SO THE OUTSIDE OF THE WATER MAIN IS AT LEAST SIX INCHES, AND PREFERABLY 12 INCHES, ABOVE OR AT LEAST 12 INCHES BELOW THE OUTSIDE OF THE OTHER PIPELINE. HOWEVER, IT IS PREFERABLE TO LAY THE WATER MAIN ABOVE THE OTHER PIPELINE.
  - B. NEW OR RELOCATED, UNDERGROUND WATER MAINS CROSSING ANY EXISTING OR PROPOSED PRESURE- TYPE SANITARY SEWER, WASTEWATER OR STORMWATER FORCE MAIN, OR PIPELINE CONVEYING RECLAIMED WATER SHALL BE LAID SO THE OUTSIDE OF THE WATERMAIN IS AT LEAST 12 INCHES ABOVE OR BELOW THE OUTSIDE OF THE OTHER PIPELINE. HOWEVER, IT IS PREFERABLE TO LAY THE WATER MAIN ABOVE THE OTHER PIPELINE.
  - C. AT THE UTILITY CROSSING DESCRIBED IN PARAGRAPHS (A) AND (B) ABOVE, ONE FULL LENGTH OF WATER MAIN PIPE SHALL BE CENTERED ABOVE OR BELOW THE OTHER PIPELINE SO THE WATER MAIN JOINTS WILL BE AS FAR AS POSSIBLE FROM THE OTHER PIPELINE. ALTERNATIVELY, AT SUCH CROSSINGS, THE PIPES SHALL BE ARRANGED SO THAT ALL WATER MAIN JOINTS ARE AT LEAST THREE FEET FROM ALL JOINTS IN VACUUM-TYPE SANITARY SEWERS, STORM SEWERS, STORMWATER FORCE MAINS, OR PIPELINES CONVEYING RECLAIMED WATER REGULATED UNDER PART III OF CHAPTER 62-610, F.A.C., AND AT LEAST SIX FEET FROM ALL JOINTS IN GRAVITY- OR PRESSURE-TYPE SANITARY SEWERS, WASTEWATER FORCE MAINS, OR PIPELINES CONVEYING RECLAIMED WATER NOT REGULATED UNDER PART III OF CHAPTER 62-610, F.A.C.

\*REQUIRED BY: HRS, STATE OF FLORIDA, PALM BEACH COUNTY PUBLIC HEALTH UNIT

LOXAHATCHEE RIVER DISTRICT

## STANDARD WATER AND SEWER SEPARATION STATEMENT

SD-30

N.T.S.

REVISION:  
APRIL, 2012





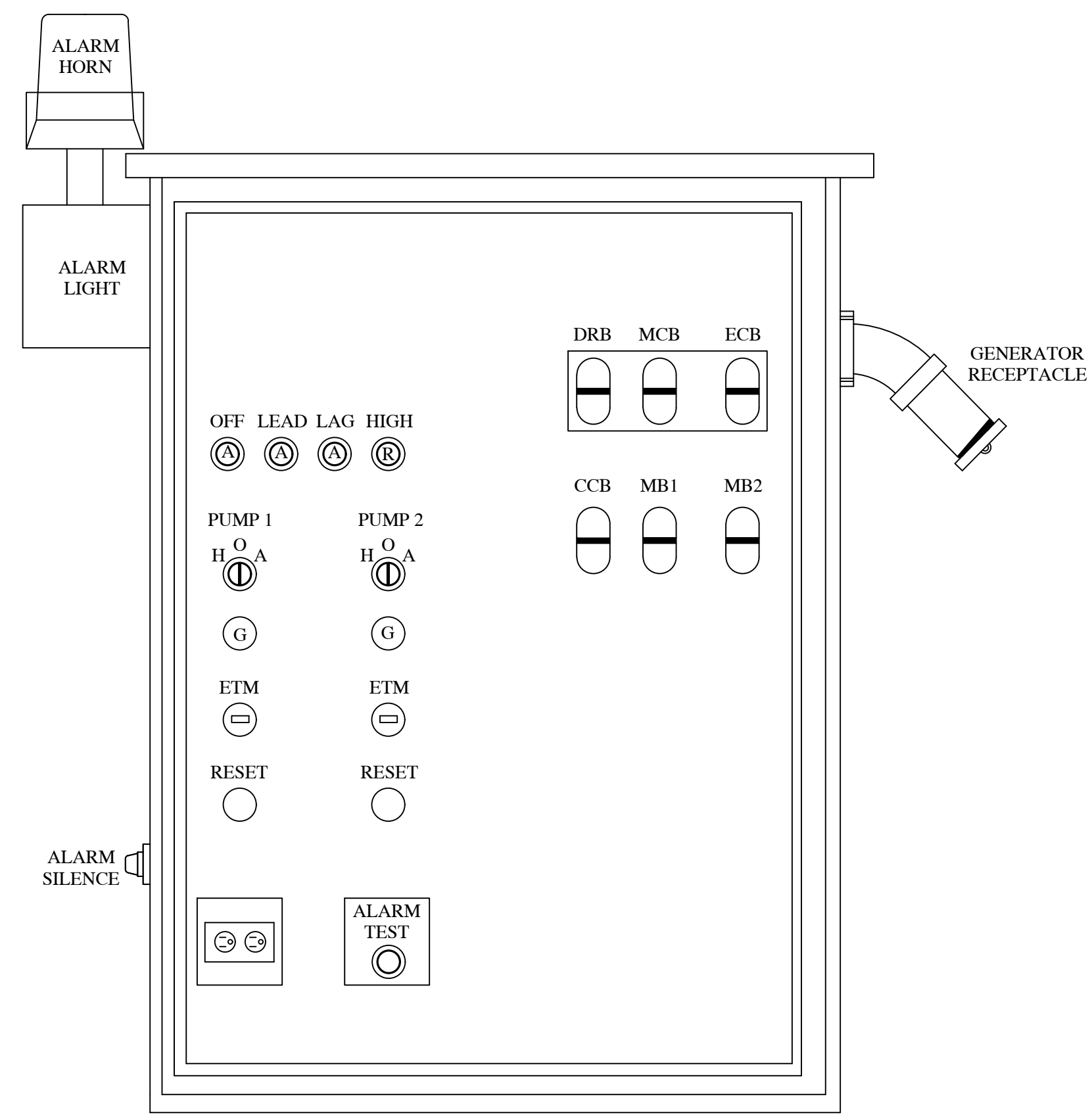

DEAD FRONT LAYOUT

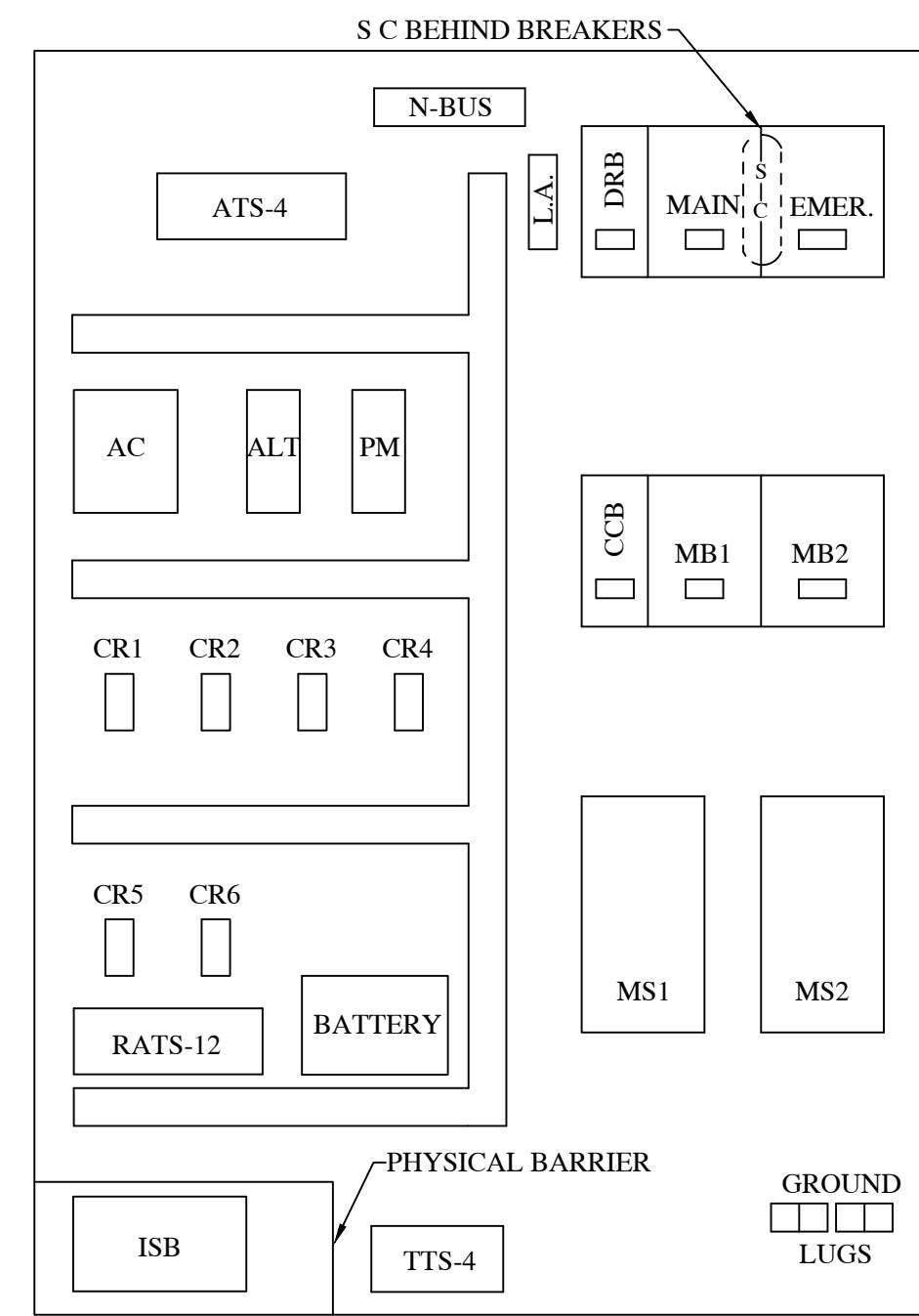

BACKPLATE LAYOUT

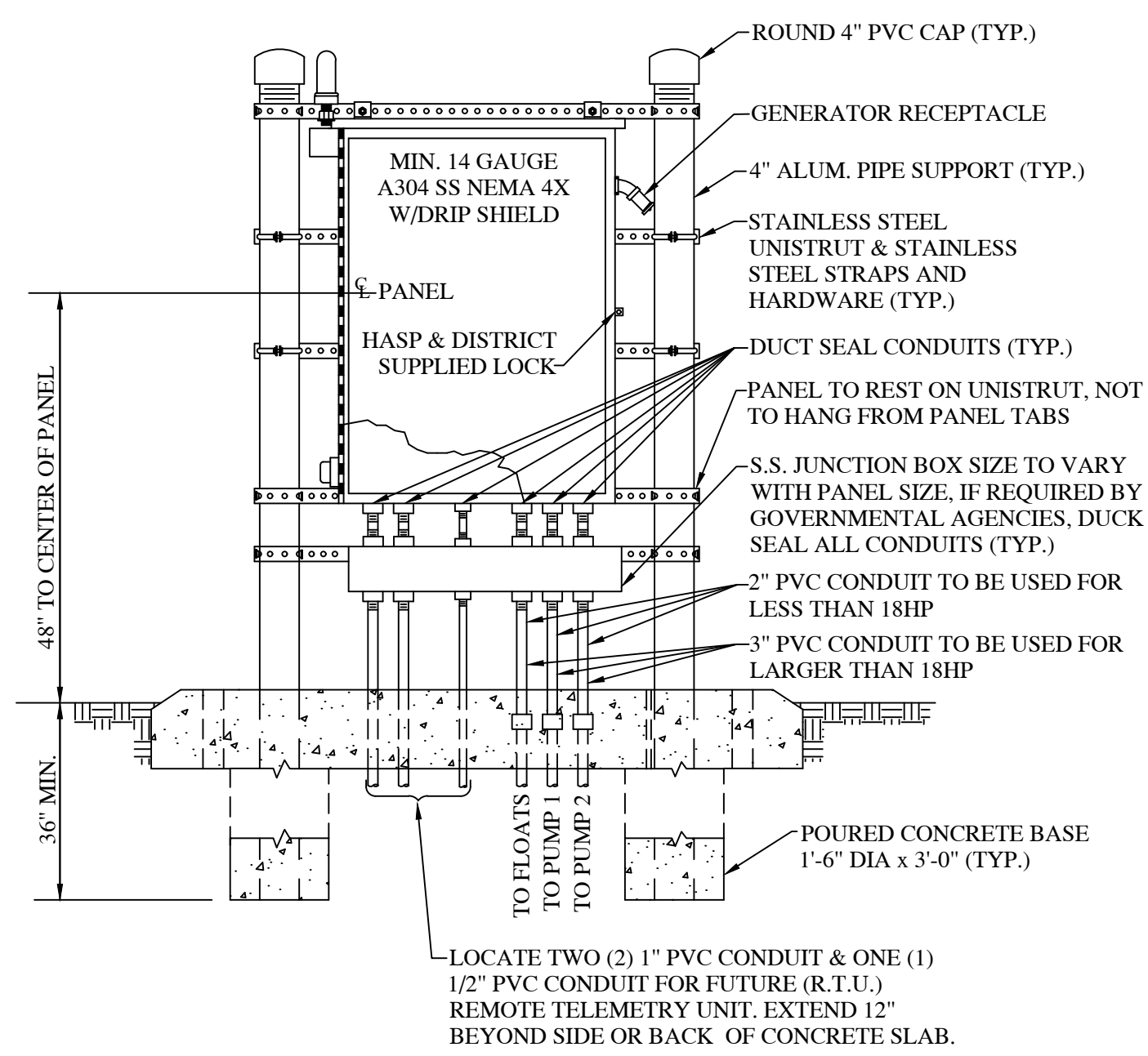

FRONT ELEVATION

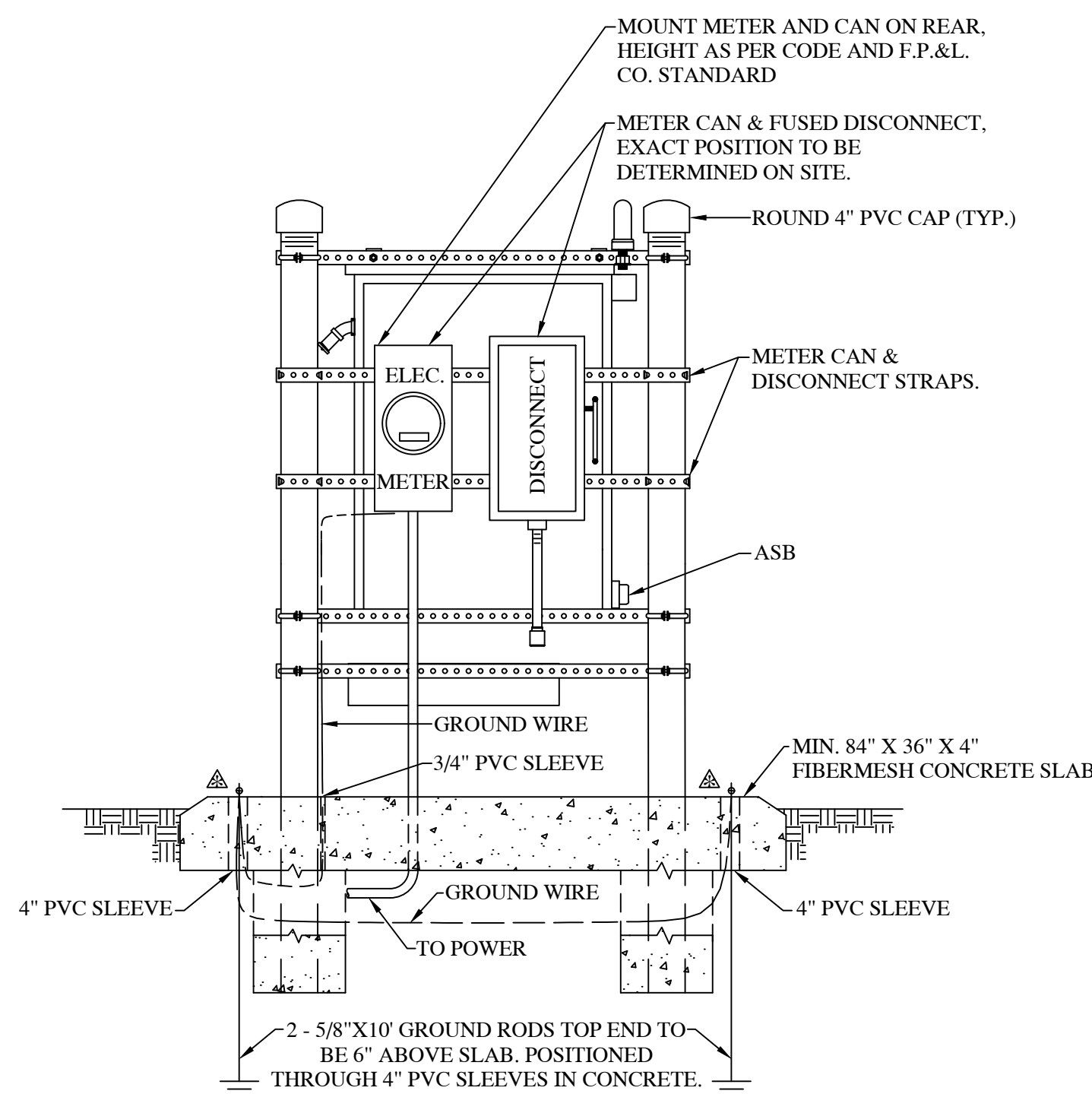

REAR ELEVATION

Rev.	Description

**LOXAHATCHEE RIVER  
ENVIRONMENTAL CONTROL DISTRICT**

2500 JUPITER PARK DRIVE  
JUPITER, FL 33458-8964  
(561) 747-5700 MAIN  
(561) 747-9929 FAX  
[www.loxahatcheeriver.org](http://www.loxahatcheeriver.org)



**LIFT STATION  
ELECTRICAL CONTROL PANEL  
STANDARD DETAILS**

Drawn:	JD
Checked:	KD
Proj. Eng.	KD
Scale:	NTS
Date:	JANUARY, 2016

**SD-33**

