



LOXAHATCHEE RIVER DISTRICT

2500 JUPITER PARK DRIVE, JUPITER, FLORIDA 33458

TEL: (561) 747-5700

FAX: (561) 747-9929

D. Albrey Arrington, Ph.D. EXECUTIVE DIRECTOR

loxahatcheeriver.org

APPLICATION / INSTALLATION PROCEDURES FOR SIMPLEX LOW PRESSURE PUMPING UNITS (DISTRICT MAINTAINED)

1. Make application for service, and
 - Pay connection fee
 - Sign Maintenance Agreement
 - Discuss location of pumping unit with District Staff
 - Receive District Standard Details
2. Purchase low pressure pumping unit and appurtenances
(Assessed areas - low pressure pumping unit price included in assessment)
3. Contractor to conduct Continuity test on pumps upon pickup.
4. Arrange for **MANDATORY** preconstruction meeting at site with:
 - District Inspector (Call Lenny Giacovelli 561 262 3447)
 - Contractor
 - Property Manager or Homeowner
 - Electrician
 - Plumber
5. Inspection schedule must be followed (listed in chronological order):
 - A. Wet well Inspection
 - Plumbness/Level
 - Anti-floatation Concrete
 - Rim elevation to be 2"-3" above finished grade

Stephen B. Rockoff
CHAIRMAN

Kevin L. Baker
BOARD MEMBER

Gordon M. Boggie
BOARD MEMBER

Dr. Matt H. Rostock
BOARD MEMBER

Clinton R. Yerkes
BOARD MEMBER

B. Electrical Inspection

- After electrical appurtenances are installed and approved by Municipality or County, District to be notified for inspection (24-hour notice required).
- Contractor/homeowner not to energize control panel until all inspections have been completed and approved and, only with District inspector on site.

C. Pump Startup Test

- Continuity test
- Draw down test
- Pressure test on 1.25" effluent line

D. Plumbing Inspection

- Plumbing may be moved from septic tank to wet well upon a passing pump startup and must be inspected by District staff.

E. Septic Tank Abandonment and Fill

- Tank pumped out
- Pressure washed
- Rupture tank
- Fill

Please note: All District inspections require 24-hour notice. The District strives to be proactive during the construction phase and unscheduled inspections will be made to assess progress and for conformance to LRD specifications.

NOTICE

**Call Loxahatchee River District 561 747 5700
Immediately Following Connection to Sewer System**

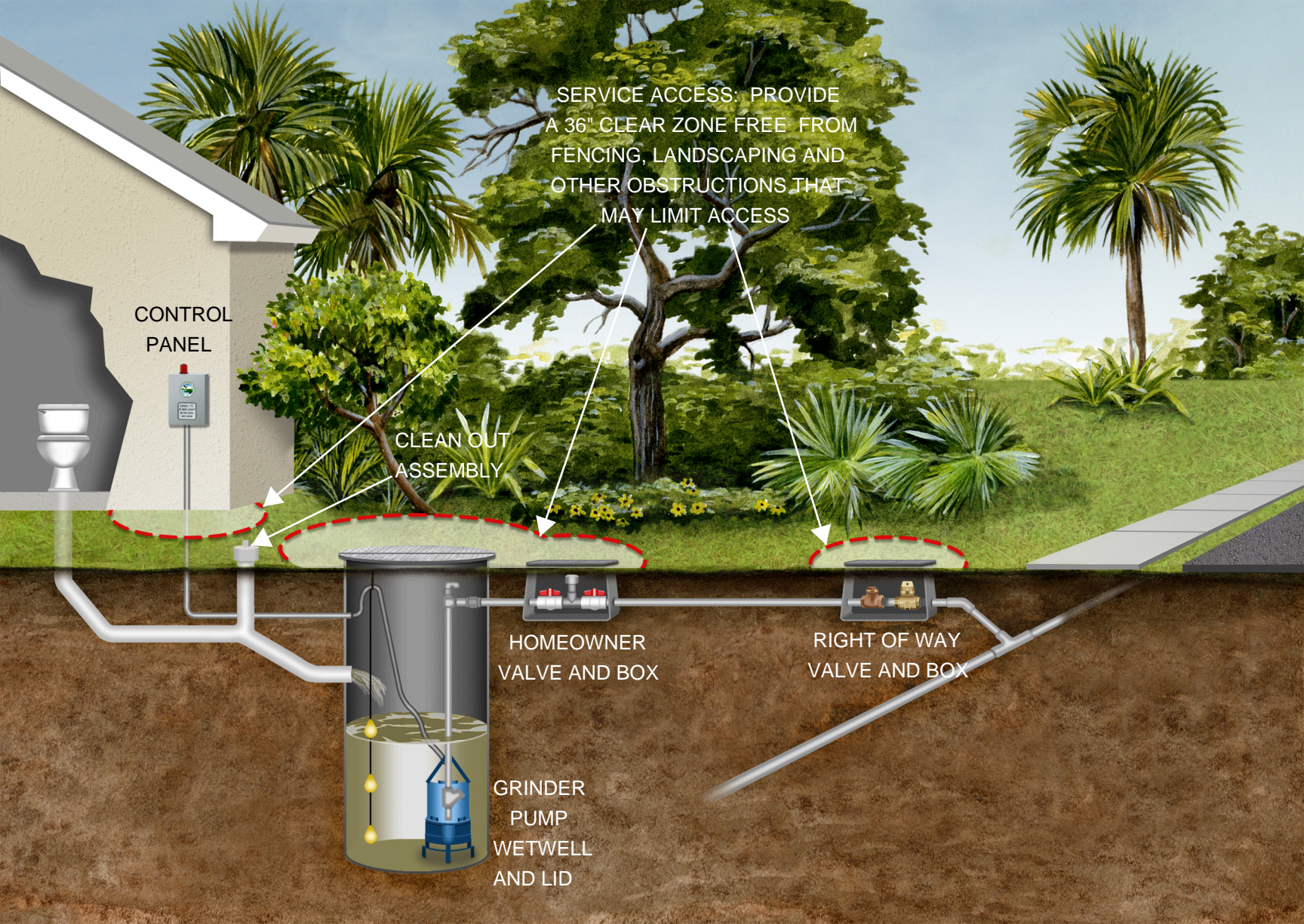

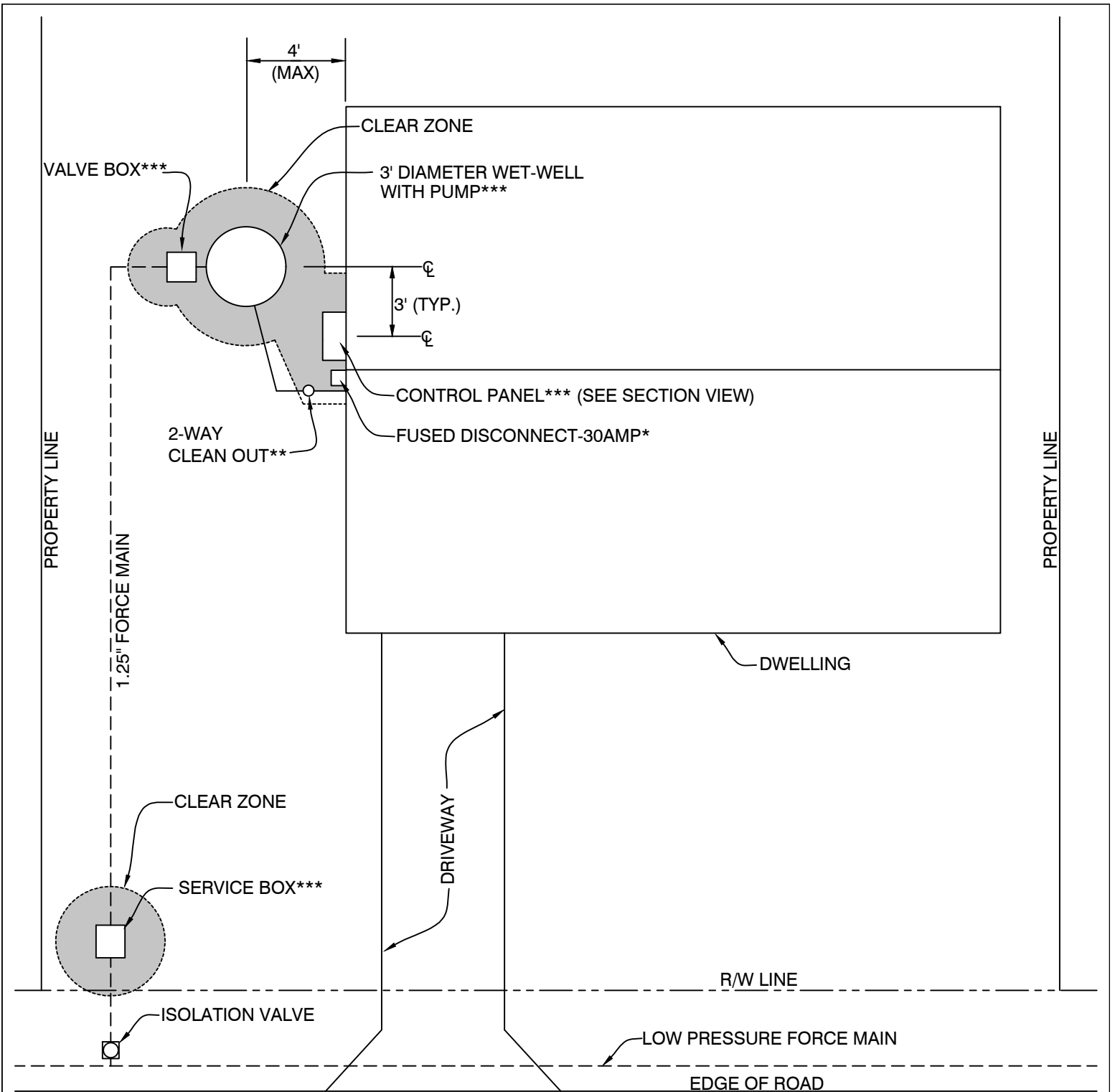

*FOR DUPLEX INSTALLATIONS (5,000 sq ft or more) USE 60 AMP FUSEABLE DISCONNECT.

**REPLACE EXISTING CLEANOUT IF NOT 2-WAY.

*** PROVIDE A 36" CLEAR ZONE FREE FROM FENCING, LANDSCAPING AND OTHER OBSTRUCTIONS THAT MAY LIMIT ACCESS.

LOXAHATCHEE RIVER DISTRICT

TYPICAL RESIDENTIAL GRINDER SYSTEM LAYOUT (PLAN VIEW)

LP-1

N.T.S.

REVISION:
JUNE, 2018

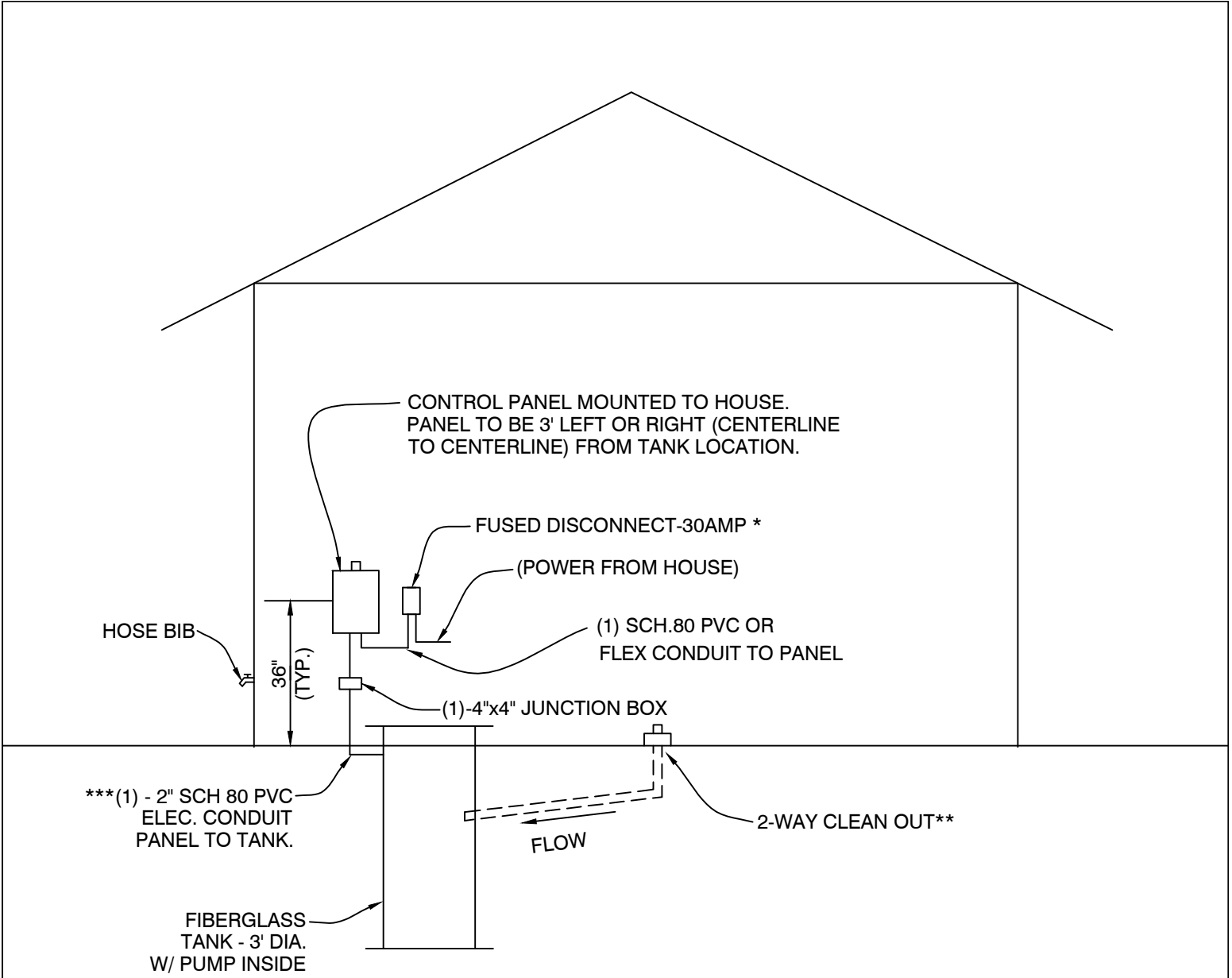

*FOR DUPLEX INSTALLATIONS (5,000 sq ft or more)
USE 60 AMP FUSEABLE DISCONNECT.

**REPLACE EXISTING CLEANOUT IF NOT 2-WAY.

***FOR DUPLEX STATIONS, USE TWO (2) - 2" SCH. 80 CONDUITS

LOXAHATCHEE RIVER DISTRICT

N.T.S.
REVISION:
APRIL, 2012

TYPICAL RESIDENTIAL
GRINDER SYSTEM LAYOUT (SECTION VIEW)

LP-2

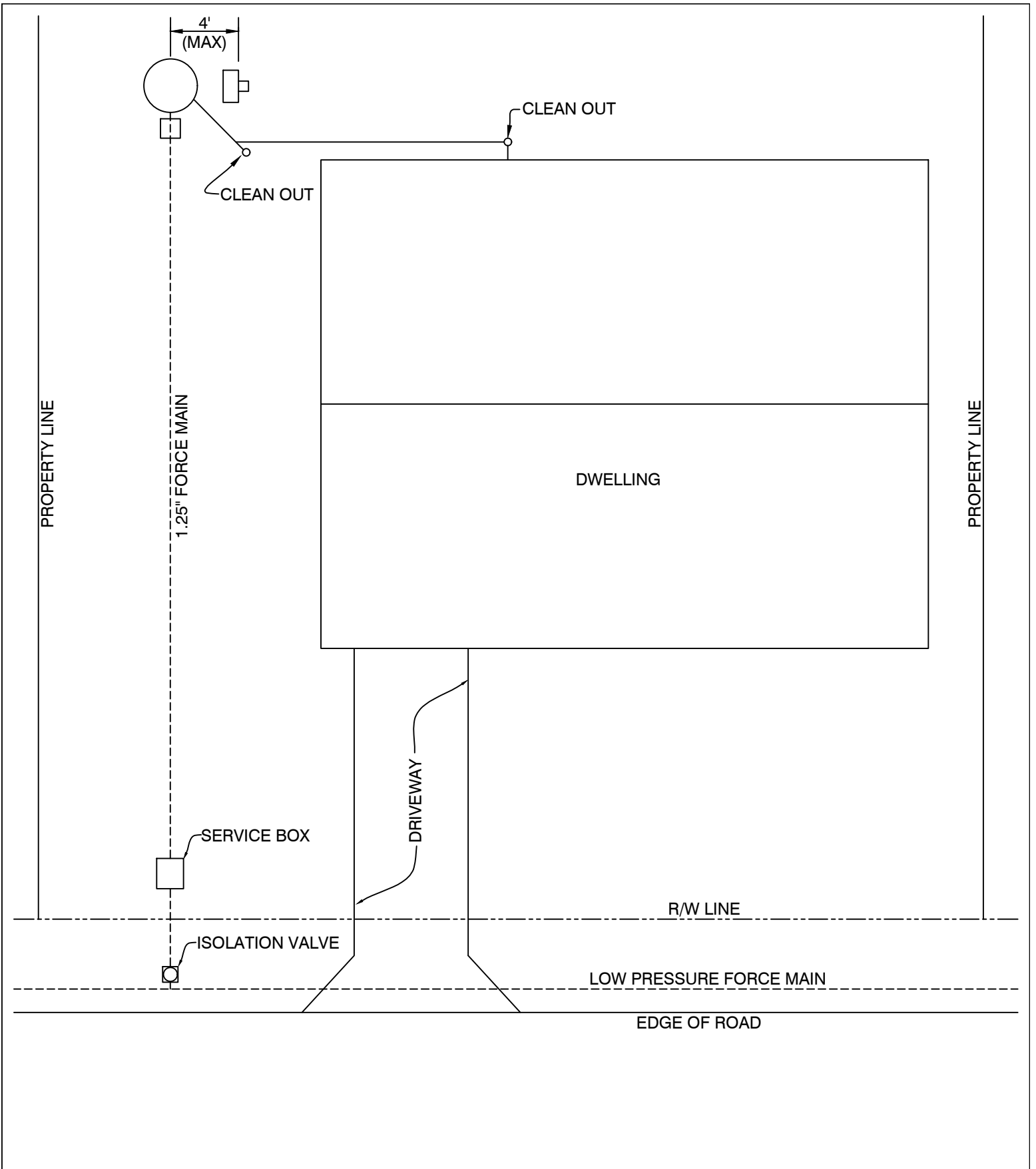

LOXAHATCHEE RIVER DISTRICT

**ALTERNATE RESIDENTIAL
GRINDER SYSTEM LAYOUT (PLAN VIEW)**

LP-3

N.T.S.

REVISION:
APRIL, 2012

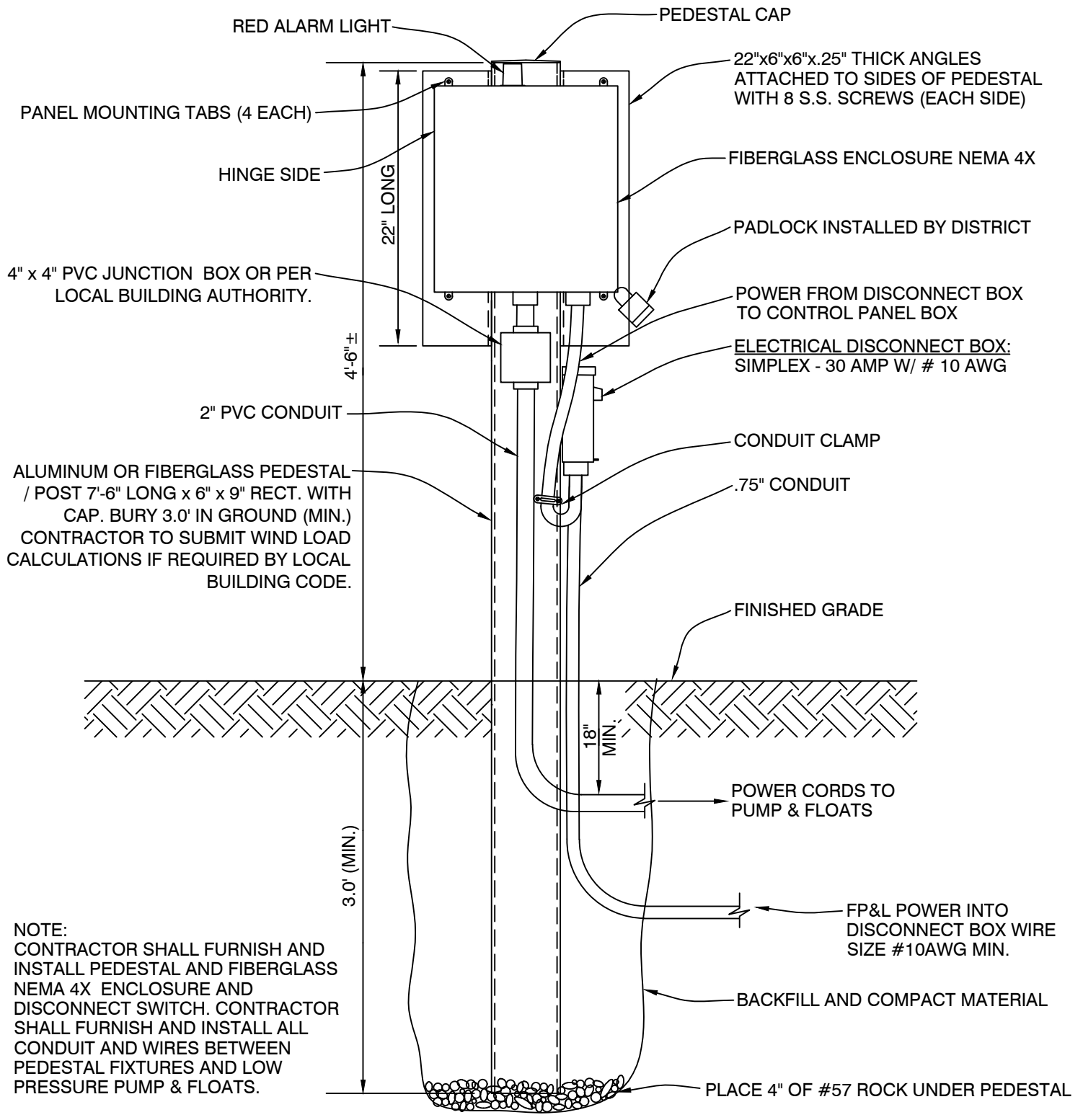

NOTE:
 CONTRACTOR SHALL FURNISH AND
 INSTALL PEDESTAL AND FIBERGLASS
 NEMA 4X ENCLOSURE AND
 DISCONNECT SWITCH. CONTRACTOR
 SHALL FURNISH AND INSTALL ALL
 CONDUIT AND WIRES BETWEEN
 PEDESTAL FIXTURES AND LOW
 PRESSURE PUMP & FLOATS.

* FOR RESIDENTIAL SIMPLEX STATIONS ONLY

LOXAHATCHEE RIVER DISTRICT

ALTERNATE RESIDENTIAL GRINDER
 SYSTEM LAYOUT FREE STANDING (1 OF 2)

LP-4

N.T.S.
 REVISION:
 MARCH, 2016

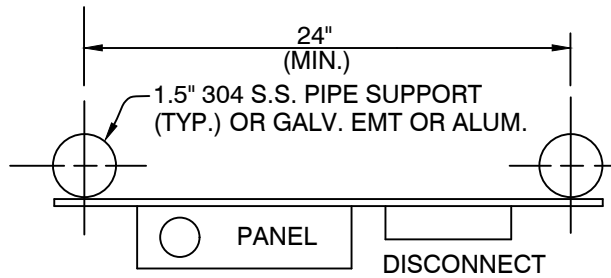

PLAN VIEW

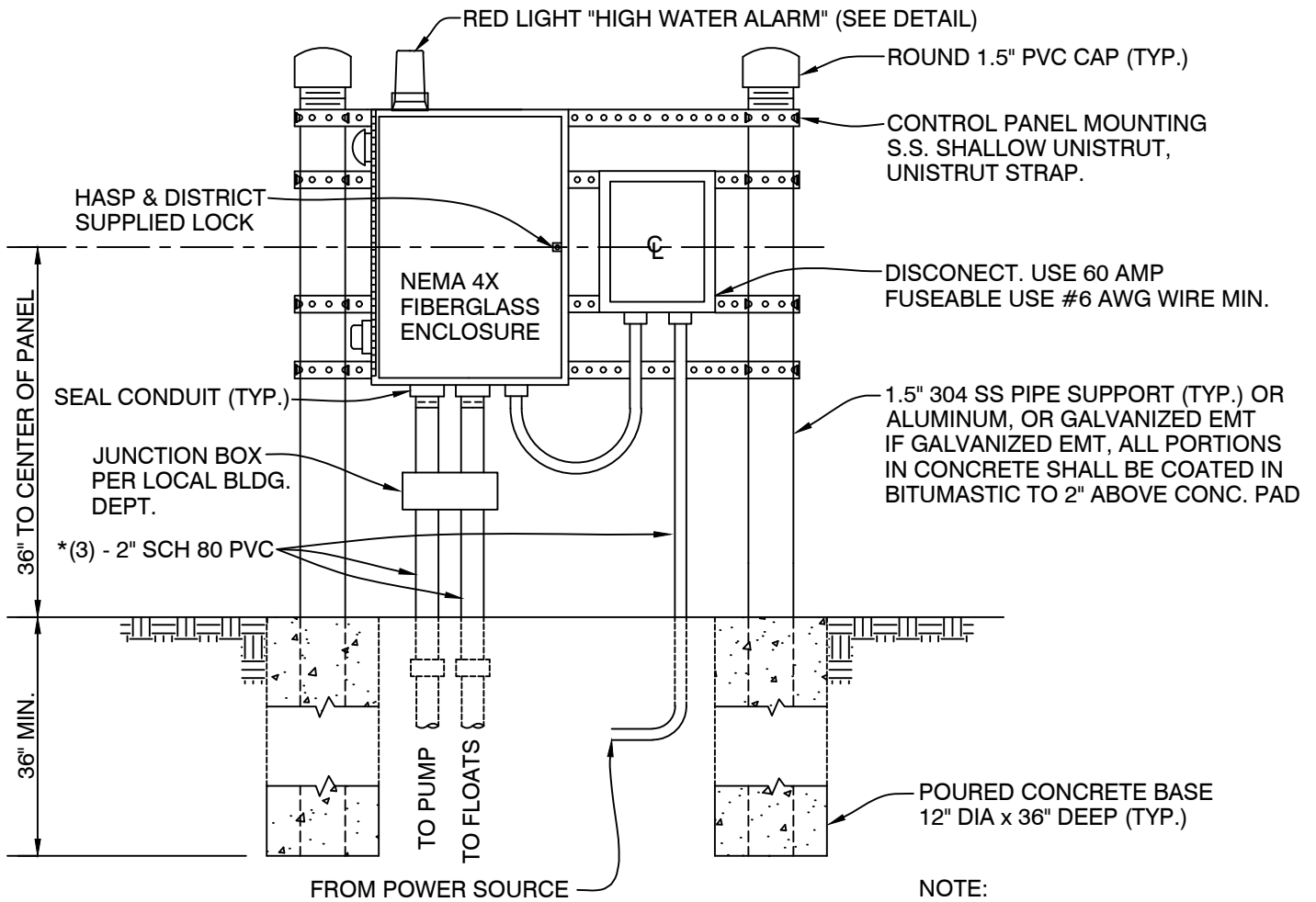

FRONT ELEVATION

* FOR RESIDENTIAL DUPLEX STATIONS ONLY

LOXAHATCHEE RIVER DISTRICT

**ALTERNATE RESIDENTIAL
GRINDER SYSTEM LAYOUT FREE STANDING (2 OF 2)**

LP-5

N.T.S.
REVISION:
APRIL, 2012

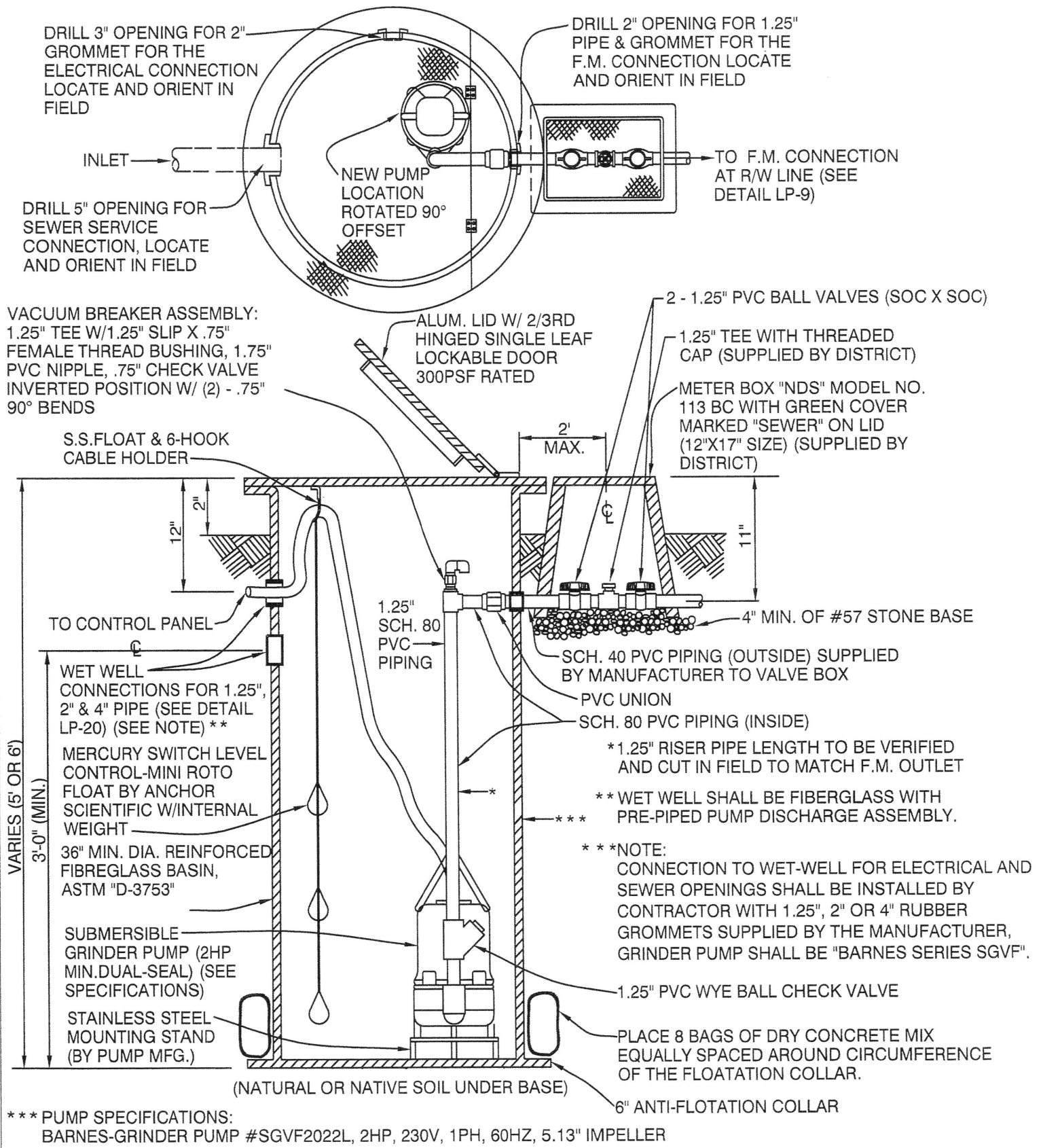

LOXAHATCHEE RIVER DISTRICT

RESIDENTIAL SIMPLEX
TYPICAL WET WELL

LP-6

N.T.S.
REVISION:
JULY, 2019

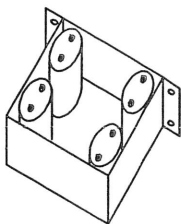
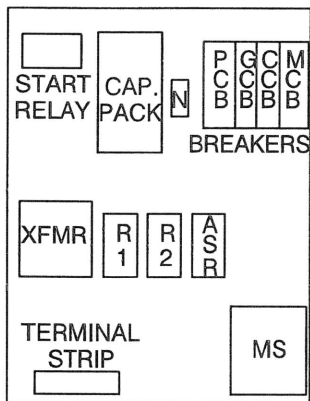
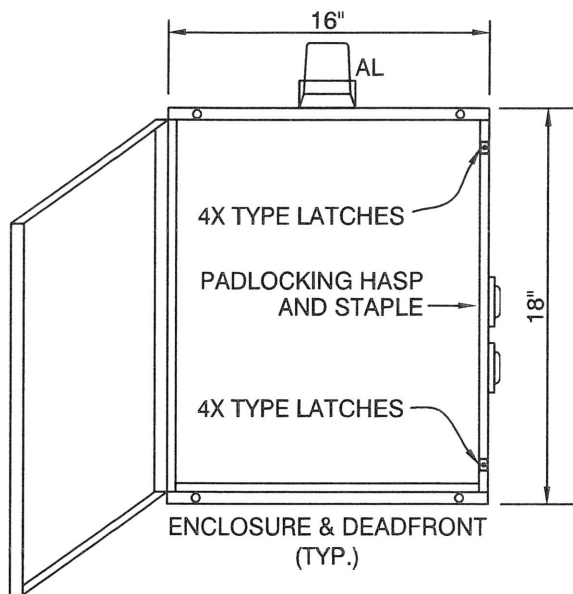
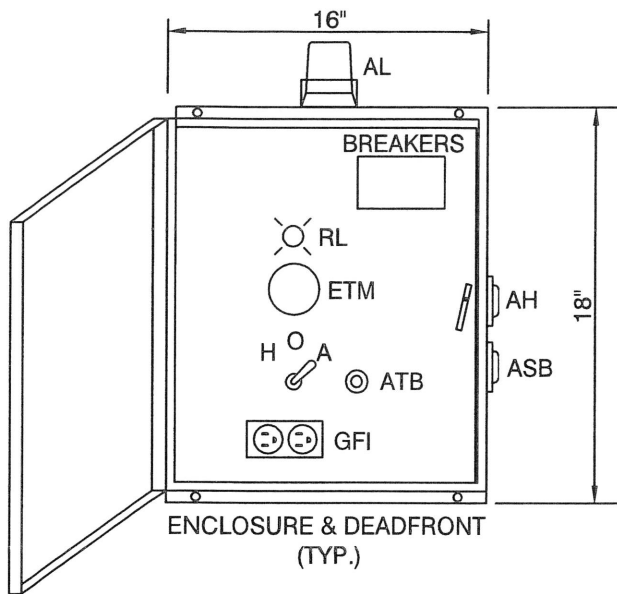

BILL OF MATERIALS

ENC	FIBERGLASS ENCLOSURE	ROBROY NEMA 4X, RJ1816HPL
PCB/MCB	PUMP & MAIN BREAKERS	SQ-D, QOU230
CCB/GCB	GFI & CONTROL BREAKERS	SQ-D, QOU115
MS	STARTER	SQ-D, 8502SBO2VO2S
OL	OVLD HTR ELEMENT	SQ-D, B25
XFMR	TRANSFORMER 50VA	SQ-D, 9070T50D13
ETM	ELAPSED TIME METER	CONTR. DYN. 120VAC, HMA303
HOA	HAND OFF AUTO SWITCH	MCGILL 20A, 910003
RL	RUN LIGHT	BACO 22M, L20SA50
AL	ALARM LIGHT	STONCO, VP11GCR
AH	ALARM HORN	FLOYD BELL, MC09201Q
*ASR	ALARM SILENCE RELAY	IDEC, SR3B05
ASB	ALARM SILENCE BUTTON	SQ-D, ZB4BA0
ATB	ALARM TEST BUTTON	SQ-D, ZB4BA2
GFI	15 AMP GFI RCPT	PASS SEYMOUR, 1595W
FU1	FUSE 1A	BUSS, MDL-1
FU2	FUSE 2A	BUSS, MDL-2
FU1-2	FUSE BLOCK	BUSS, BKS82021
OL	OVERLOAD RELAY	SQ-D, 9065SEO5
CR1-2	CONTROL RELAY	IDEC, RR2PULAC24V
CR1-2	8-PIN SOCKET	IDEC, SR2P06
TS	TERMINAL STRIP	ALTECH, TSF6012WP
CAP.PACK: MARS RUN CAP OVAL 45MF/440V, 12448 MARS STRT CAP 250V 124-156MF, 11148 GE START RELAY, 16104		} TO MATCH GRINDER PUMP'S

* OR APPROVED EQUAL

* PANEL & COMPONENTS SHALL CONFORM TO INDUSTRIAL UL LISTING PRE SEC. 508 N.E.C.

LOXAHATCHEE RIVER DISTRICT

**RESIDENTIAL SIMPLEX
CONTROL PANEL LAYOUT**

LP-7

N.T.S.

REVISION:
APRIL, 2012

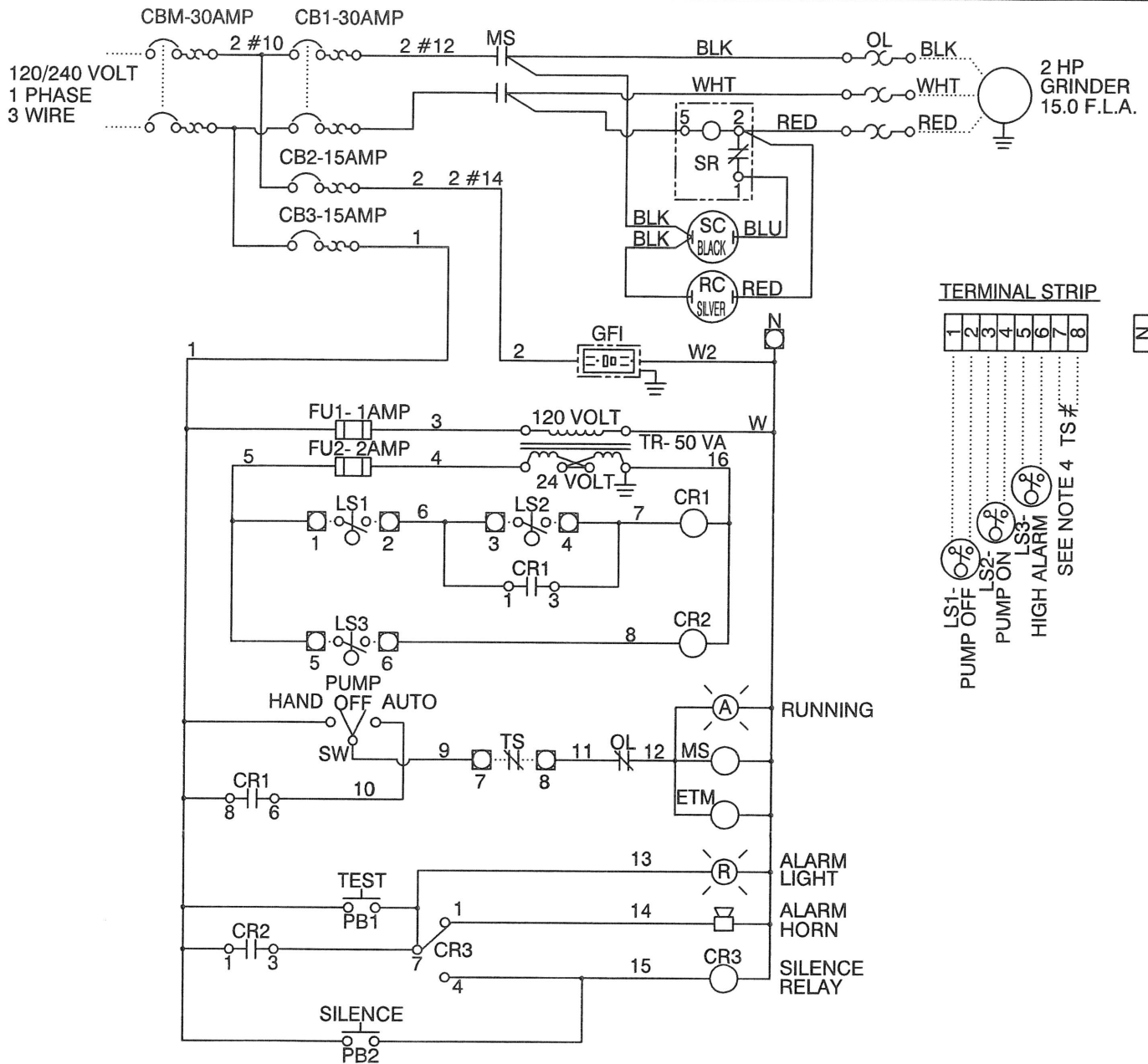

NOTES:

- 1.) PANEL GROUND TERMINAL MUST BE CONNECTED TO EARTH GROUND.
- 2.) FACTORY WIRING IS SHOWN _____
FIELD WIRING IS SHOWN
- 3.) RECOMMENDED TIGHTENING TORQUES FOR TERMINALS 240 VOLT POWER 30 POUND INCHES. 120 VOLT POWER, CONTROL & LOW VOLTAGE - 20 POUND INCHES.
- 4.) THERMAL SAFETY SWITCH (TS) CONTACTS ARE NOT IN ALL MOTORS. IF MOTOR DOES NOT HAVE SWITCH, THESE TERMINALS MUST BE JUMPED.
- 5.) LAYOUT TO MEET CUSTOMER'S REQUIREMENTS.

LOXAHATCHEE RIVER DISTRICT

**RESIDENTIAL SIMPLEX
ELECTRICAL SCHEMATIC**

LP-8

N.T.S.

REVISION:
APRIL, 2012

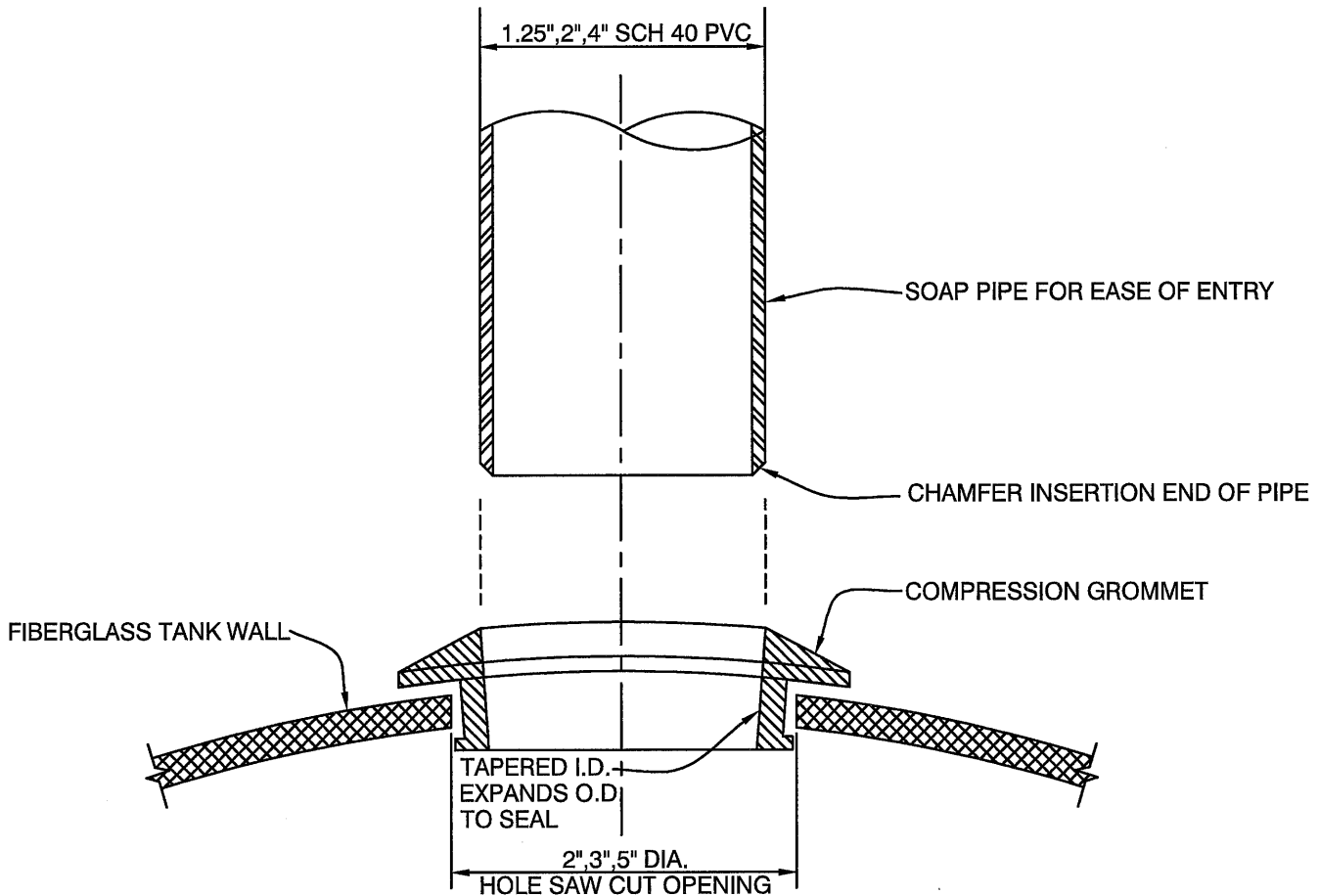

NOTES:

FOR A 4" PVC PIPE, USE A 5" DIA. HOLE SAW TO CUT OUT COUPON FROM WET WELL WALL. THE MANUFACTURER WILL SUPPLY THE PROPER COMPRESSION GASKET FOR A 4" DIA. PVC PIPE

FOR A 2" PVC PIPE, USE A 3" DIA. HOLE SAW TO CUT OUT COUPON FROM WET WELL WALL. THE MANUFACTURER WILL SUPPLY THE PROPER COMPRESSION GASKET FOR A 2" DIA. PVC PIPE

FOR A 1.25" PVC PIPE, USE A 2" DIA. HOLE SAW TO CUT OUT COUPON FROM WET WELL WALL. THE MANUFACTURER WILL SUPPLY THE PROPER COMPRESSION GASKET FOR A 1.25" DIA. PVC PIPE

TERMINATE INFLUENT SEWER LINE 3" INSIDE TANK.

LOXAHATCHEE RIVER DISTRICT

N.T.S.

REVISION:
APRIL, 2012

PIPE CONNECTION DETAIL

LP-21

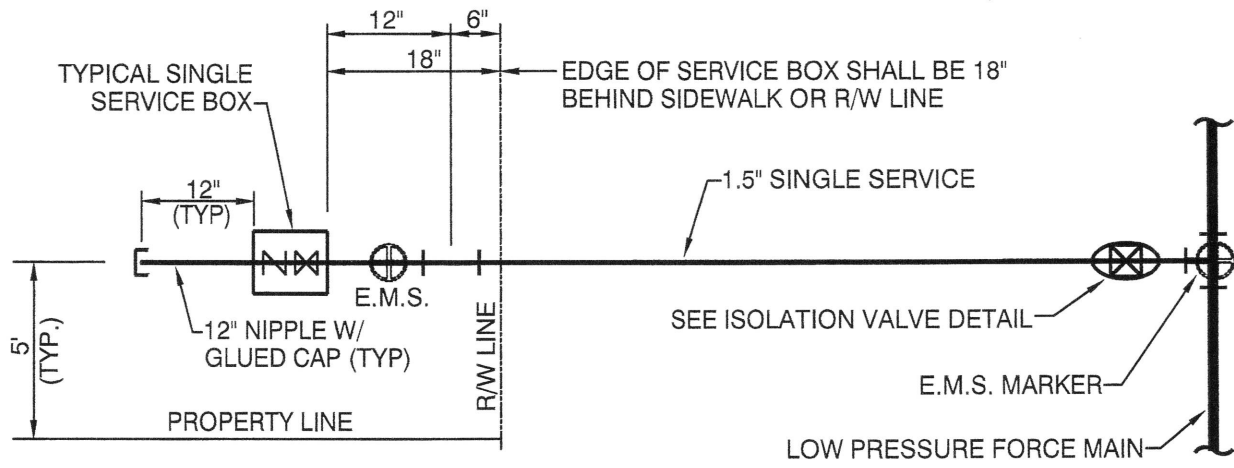

PLAN VIEW

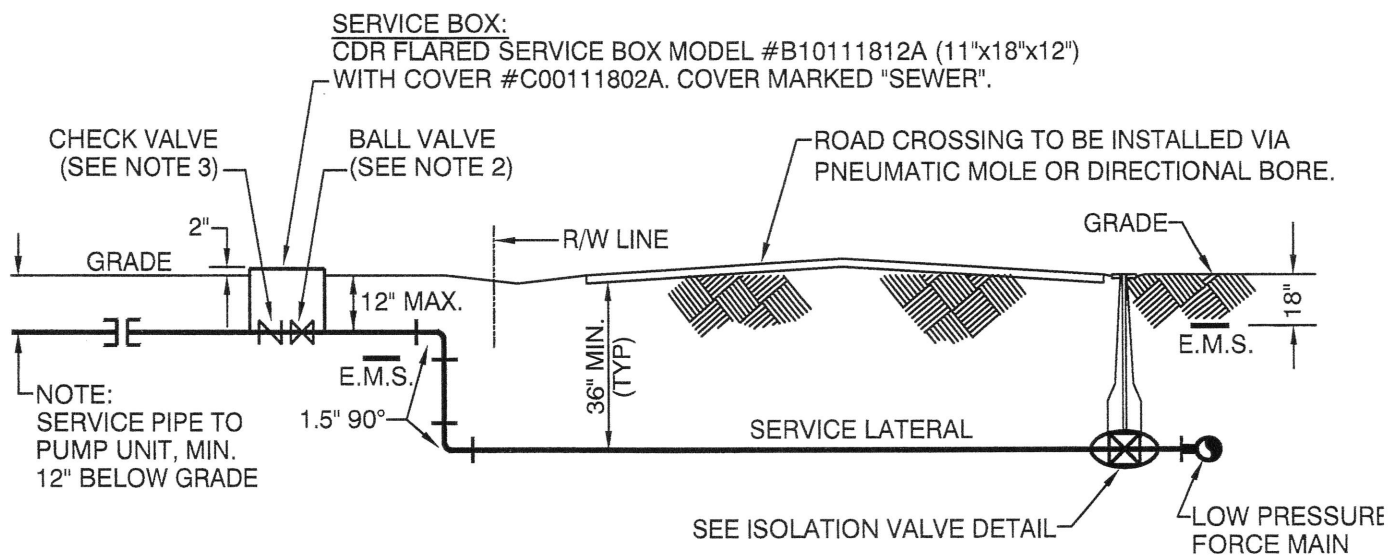

TYPICAL ROAD CROSSING SECTION VIEW

NOTES:

1. SERVICE LOCATIONS ON PLANS ARE APPROXIMATE. INSTALLED LOCATIONS TO BE COORDINATED WITH EXISTING ONSITE PLUMBING OR PROPOSED ONSITE CONSTRUCTION.
2. BALL VALVES SHALL BE FORD MODEL #B11-666M WITH 2" BRASS OPERATING NUT.
3. ALL CHECK VALVES SHALL BE PROFLO MODEL PFX31.
4. ALL PIPING IN AND 6-INCHES BEYOND THE SERVICE BOX SHALL BE SCH 80 PVC.
5. INSTALL MINIMUM 4" OF NO 57 WASHED STONE BENEATH ALL SERVICE BOXES AND VALVE BOXES AND AROUND ALL PIPE PENETRATIONS THROUGH SERVICE BOXES.
6. FOR HDPE TO PVC TRANSITIONS USE FORD PACK JOINT COUPLING PVC X PE W/ 304SS STIFFENER.

LOXAHATCHEE RIVER DISTRICT

N.T.S.	TYPICAL SINGLE SERVICE SCHEMATIC	LP-22
REVISION: AUG, 2022		

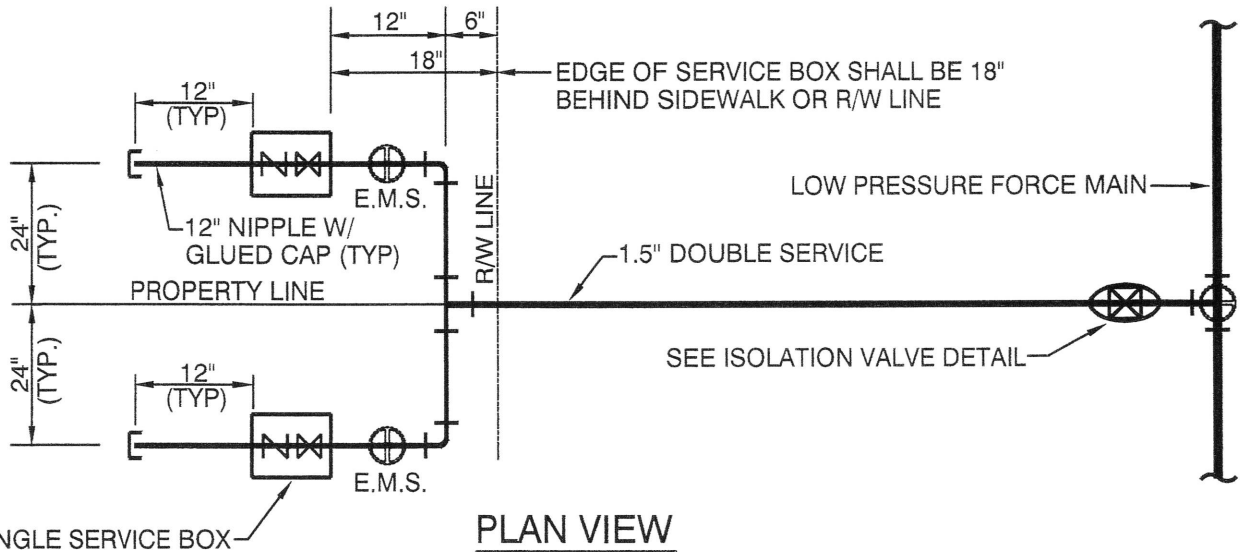

TYPICAL SINGLE SERVICE BOX

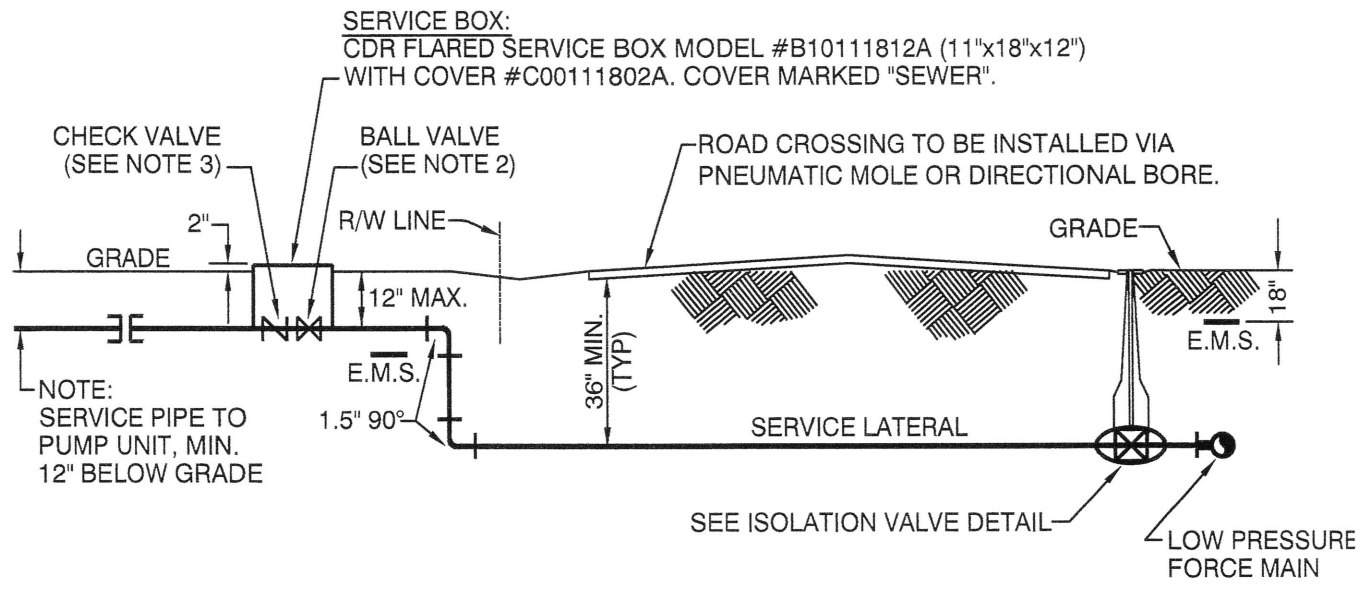

NOTES:

1. SERVICE LOCATIONS ON PLANS ARE APPROXIMATE. INSTALLED LOCATIONS TO BE COORDINATED WITH EXISTING ONSITE PLUMBING OR PROPOSED ONSITE CONSTRUCTION.
2. BALL VALVES SHALL BE FORD MODEL #B11-666M WITH 2" BRASS OPERATING NUT.
3. ALL CHECK VALVES SHALL BE PROFLO MODEL PFX31.
4. ALL PIPING IN AND 6-INCHES BEYOND THE SERVICE BOX SHALL BE SCH 80 PVC.
5. INSTALL MINIMUM 4" OF NO 57 WASHED STONE BENEATH ALL SERVICE BOXES AND VALVE BOXES AND AROUND ALL PIPE PENETRATIONS THROUGH SERVICE BOXES.
6. FOR HDPE TO PVC TRANSITIONS USE FORD PACK JOINT COUPLING PVC X PE W/ 304SS STIFFENER.

LOXAHATCHEE RIVER DISTRICT

N.T.S.	TYPICAL DOUBLE SERVICE SCHEMATIC	LP-23
REVISION: AUG, 2022		

1. LOW PRESSURE PUMPING UNITS SHALL BE LOCATED SO THAT SURFACE WATER RUN OFF SHALL NOT INTERFERE WITH ELECTRICAL COMPONENTS.
2. MANUFACTURER SHALL SUPPLY AND ATTACH ELECTRICAL CONTROL PANEL SCHEMATIC TO INSIDE FACE OF CONTROL PANEL DOOR (LAMINATED).
3. THE DISTRICT WILL BE CERTIFYING ALL LOW PRESSURE LIFT STATIONS WHEN COMPLETE. MANUFACTURER SHALL SCHEDULE A START UP TEST AND SUBMIT ALL AS-BUILT DATA TO THE DISTRICT FOR CERTIFICATION.
4. LIFT STATION AND CONTROL PANEL SHALL BE LOCATED SO THAT BOTH ARE ACCESSIBLE FOR MAINTENANCE. PROVIDE A 36" CLEAR ZONE FREE FROM FENCING, LANDSCAPING AND OTHER OBSTRUCTIONS THAT MAY LIMIT ACCESS.
5. WHERE FEASIBLE, HOMEOWNER SHALL PROVIDE WATER HOSE BIB. HOSE FOR MAINTENANCE OPERATIONS.
6. AIR RELEASE VALVE AND/OR VACUUM RELIEF VALVES SHALL BE PROVIDED ON ALL LOW PRESSURE FORCE MAIN INSTALLATION IMMEDIATELY UPSTREAM OF DISCHARGE POINT TO REGIONAL GRAVITY OR FORCE MAIN SYSTEMS.
7. FORCE MAIN DETECTABLE TAPE & MAGNETIC LOCATING DEVICES WILL BE INSTALLED OVER FORCE MAIN, VALVES, AND SERVICES.

LOXAHATCHEE RIVER DISTRICT

N.T.S.
REVISION: JUNE, 2018

GENERAL NOTES

LP-35

Loxahatchee River Environmental Control District
2500 Jupiter Park Drive
Jupiter, Florida 33458

**LICENSE FOR MAINTENANCE of
LOW PRESSURE SEWER SYSTEM PUMP STATION**

_____, and all co-owners, heirs, successors, grantees, and assigns, (“Owners”) of the Property at the address of, _____ with a legal description attached hereto as Exhibit “A” (“Property”), intend to furnish and install a simplex grinder low pressure pumping unit, control panel and valve box (“Pump Station”) with appurtenant pipe and electrical apparatus (“Pipe” & “Electrical”) of a type and in a manner approved by the Loxahatchee River District (“District”).

Owners shall operate, maintain, repair and replace the Electrical. Owners, also, agree to pay for the replacement of the Pump Station and any parts associated with it, if the Pump Station is damaged as a result of Owners fault.

Owners understand and agree that the District will perform inspections, operation, maintenance and replacement of the Pump Station and Pipe as necessary. Owners, also, understand and agree that the District will provide maintenance service on the Pump Station and Pipe at no additional charge to the Owners.

In order to provide the District access to the Pump Station and Pipe, the Owners hereby grant a license to the District to go onto the Property during reasonable working hours.

WITNESSES: OWNERS:

WITNESS SIGNATURE
Print Name:

By: _____
Print Name:

WITNESS SIGNATURE
Print Name:

By: _____
Print Name:

STATE OF FLORIDA
COUNTY OF _____

The foregoing instrument was acknowledged before me by means of ___ physical presence or ___ online notarization, this ___ day of _____, 20___, by _____ who is/are personally known to me or who has/have produced _____ as identification.

[Notary Ink Stamp]

Notary Public, State of Florida



LOXAHATCHEE RIVER DISTRICT

2500 JUPITER PARK DRIVE, JUPITER, FLORIDA 33458

TEL: (561) 747-5700

FAX: (561) 747-9929

D. Albrej Arrington, Ph.D. EXECUTIVE DIRECTOR

loxahatcheeriver.org

LOW PRESSURE SEWER SYSTEM GENERAL OPERATING INSTRUCTIONS

GENERAL INFORMATION

Your home is equipped with a wastewater disposal system known as a low-pressure grinder pump system. The key element of the system is the self-contained grinder pump unit. The fiberglass tank, which houses the pump, collects all the effluent from your house which previously discharged to a septic tank. The solid materials are then ground to a small size suitable for pumping as a slurry with the effluent water. The grinder pump generates sufficient pressure to pump this slurry from your home through a low-pressure force main to the nearest existing sanitary collection system. There are shut off and check valves that isolate your pumping unit from the low-pressure force main in the street right-of-way. These valves are located in boxes at your front property line and at the pumping unit. You should be familiar with their location and operation in the event on site repairs are necessary. Additionally, you should make a location sketch of the small PVC force main between the pumping unit and the street right-of-way line. Keep this sketch in a safe place for future reference.

The District can assist you in locating these valves.

Listed below are typical instructions that are being recommended to users of a grinder pump low pressure system:

1. The following items should not be introduced into any house sewer, either directly or through a garbage disposal unit:
 - a. Glass
 - b. Metal
 - c. Cloth (socks, rags, etc.)
 - d. Plastic Objects (toys, utensils, etc.)
 - e. Diapers, Diaper Wipes, Sanitary Napkins or Tampons
 - f. Fats, Oils and Grease (FOG)
 - g. Bones and other grease laden products
 - h. Dental Floss and Picks
 - i. String, any kind
 - j. Q-Tips

Stephen B. Rockoff
CHAIRMAN

Kevin L. Baker
BOARD MEMBER

Gordon M. Boggie
BOARD MEMBER

Dr. Matt H. Rostock
BOARD MEMBER

Clinton R. Yerkes
BOARD MEMBER

2. Grease - Grease in the wet well is a major cause of system backups. Float switches, which regulate the liquid levels in the pumping chamber, can be made inoperative by accumulations of grease on the float system. As with any sewer system, every effort should be made to remove grease from dishes and eating utensils prior to operating dishwashers and garbage disposal units.
3. Never introduce into any sewer:
 - a. Explosives
 - b. Flammable Material
 - c. Lubricating Oils and/or Grease
 - d. Strong Chemicals
 - e. Gasoline
 - f. Paints
4. Unoccupied Homes - If your home is left unoccupied for longer than a week or two, the pump system should be purged, i.e. run clean water into the pumping until the pump starts. Turn off the water supply and allow the pump to run until it shuts off automatically. Do not disconnect power to the unit.
5. Power Failure - Obviously, like other household appliances a grinder pump cannot operate and dispose of wastewater without electrical power. The storage capacity of most units varies between 70 and 80 gallons. This is an adequate reserve for an average one family home for at least 24 hours if water usage is kept to a minimum. Keep in mind that the normal toilet uses about 3 to 5 gallons per flush.
6. Pump Failure Alarm - Your low-pressure grinder pump contains a built in alarm signal which will activate in the event of a high liquid level in the basin. This signal is connected to a visual and/or audible alarm which will provide you with adequate warning that service is required. During the interval prior to the arrival of a service technician, water usage should be kept to a minimum. During normal working hours you can call 747-5709 for an emergency. After hours, the emergency number is 747-5708.
7. District Response in Emergencies - Maintenance of the pumping unit and its components will be the responsibility of the District for all residential and 3 phase non-residential low flow units. The covers all labor involved for emergency calls or normal maintenance and any parts or materials that are used.
8. Access - Maintain a 36" clear zone free from fencing, landscaping, and other obstructions that may limit access.

Fats, Oils, and Greases aren't just bad for your arteries and your waistline; they're bad for sewers, too.

Sewer overflows and backups can cause health hazards, damage home interiors, and threaten the environment. An increasingly common cause of overflows is sewer pipes blocked by grease. Grease gets into the sewer from household drains as well as from poorly maintained grease traps in restaurants and other businesses.

Where does the grease come from?

Most of us know grease as the byproduct of cooking. Grease is found in such things as:

- Meat fats
- Lard
- Cooking oil
- Shortening
- Butter and margarine
- Food scraps
- Baking goods
- Sauces
- Dairy products

Too often, grease is washed into the plumbing system, usually through the kitchen sink. Grease sticks to the insides of sewer pipes (both on your property and in the streets). Over time, the grease can build up and block the entire pipe.

Home garbage disposals do not keep grease out of the plumbing system. These units only shred solid material into smaller pieces and do not prevent grease from going down the drain.

Commercial additives, including detergents, that claim to dissolve grease may pass grease down the line and cause problems in other areas.

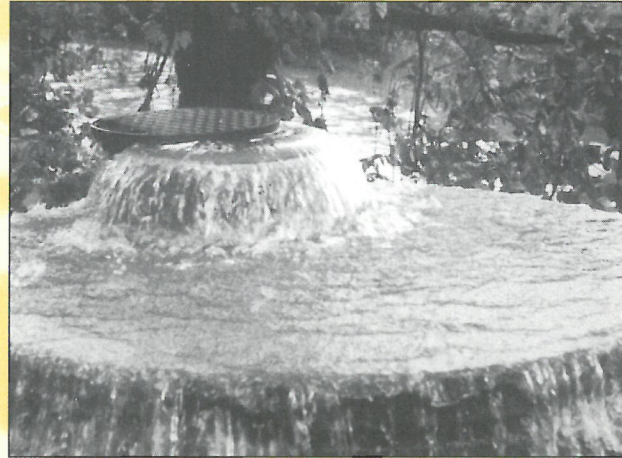

© James L. Graham, Jr., P.E.

The results can be:

- Raw sewage overflowing in your home or your neighbor's home;
- An expensive and unpleasant cleanup that often must be paid for by **you, the homeowner**;
- Raw sewage overflowing into parks, yards, and streets;
- Potential contact with disease-causing organisms; and
- An increase in operation and maintenance costs for local sewer departments, which causes higher sewer bills for customers.

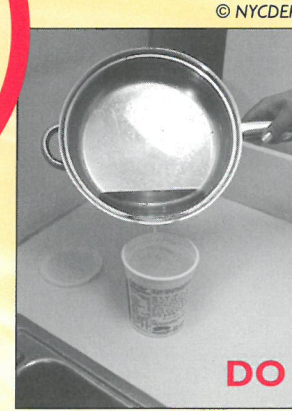

© NYCDEP

What we can do to help

The easiest way to solve the grease problem and help prevent overflows of raw sewage is to keep this material out of the sewer system in the first place.

There are several ways to do this.

- 1) Never pour grease down sink drains or into toilets.
- 2) Scrape grease and food scraps from trays, plates, pots, pans, utensils, and grills and cooking surfaces into a can or the trash for disposal (or recycling where available).
- 3) Do not put grease down garbage disposals. Put baskets/strainers in sink drains to catch food scraps and other solids, and empty the drain baskets/strainers into the trash for disposal.
- 4) Speak with your friends and neighbors about the problem of grease in the sewer system and how to keep it out. Call your local sewer system authority if you have any questions.